



Tecnostamp

PRESS BRAKE TOOLING

www.tecnostamp.eu

ED21



EXPERIENCE & INNOVATION



TECNOSTAMP, fondata nel 1978 a Piacenza, è diventata nel corso degli anni, una delle più grandi ed affermate aziende italiane nella produzione, progettazione e vendita di utensili di piegatura; in continua espansione grazie ad una capillare rete di rivenditori dislocati in ogni parte del mondo. In questa direzione molti investimenti sono stati fatti: l'acquisto di nuove macchinari e l'esigenza di dotarsi di tecnologie avanzate con lo scopo di incrementare il livello qualitativo e la gamma degli utensili a catalogo.

La produzione comprende una vasta gamma di utensili standard – punzoni matrici ed accessori- adatti ai vari tipi di presse piegatrici; tutti i prodotti TECNOSTAMP sono realizzati con acciai di alta qualità temprati ad induzione nelle parti usurabili per una maggiore durata e sottoposti ad un accurato controllo qualità e assistenza post vendita.

Non solo prodotti standard ma soluzioni mirate per applicazioni specifiche nei vari settori della lavorazione della lamiera. La chiave del grande successo di TECNOSTAMP è proprio il servizio dedicato ai clienti: il cliente prima di tutto!

L'azienda crede fortemente nella forza della sua produzione e nella competenza dei suoi collaboratori che quotidianamente mettono a disposizione le proprie capacità professionali e la propria esperienza per una continua crescita trovando soluzioni mirate e personalizzate in grado di soddisfare le esigenze dei clienti in modo veloce ed efficiente.

Ricerca, innovazione, qualità e passione sono i punti forza che hanno costruito negli anni il successo del marchio TECNOSTAMP e accompagnano la sua espansione nel mercato globale.



TECNOSTAMP, founded in 1978 in Piacenza, has become over the years, one of the biggest and most important Italian companies in the production, design and sale of bending tools; it's a world-wide-expanding company with a large network of dealers across the globe.

For this purpose many investments have been made: the purchase of new machines and the need to equip with advanced technologies in order to increase quality and expanding range of tools in the catalogue.

The production includes a wide range of standard tools- punches, dies and accessories – suitable for all types of Press Brakes; all TECNOSTAMP products are made of high quality hardened steels for induction on wear parts for longer life and subjected to accurate quality control and after sales service.

Not only standard products but targeted solutions for specific applications in the various sheet metal processing sectors.

The key to great success of TECNOSTAMP is the service dedicated to customers: the customer first of all!

The company strongly believes in the strength of its production and the expertise of its employees who daily make available their professional skills and experience for continuous growth by finding targeted and customized solutions that can meet customer needs quickly and efficiently.

Research, innovation, quality and passion are the strengths that have built over the years the success of TECNOSTAMP brand and drive its expansion into the global market.



OUR PRODUCT LINES



INDICE / INDEX

RED		AMADA - PROMECAM STYLE	11
BLUE		TRUMPF STYLE	41
PLATINUM		WILA STYLE	55
ORANGE		BYSTRONIC - BEYELER STYLE	65
BLACK		LVD STYLE	79
RAINBOW		AJIAL - AMERICAN - COLGAR - COLLY - HÄMMERLE - EHT - NEWTON - WEINBRENNER STYLES	85
SKY		LAME - SUPPORTO PER LAME - INSERTI A (Z) - SUPPORTI PER INSERTI A (Z) - INSERTI RAGGIATI - SUPPORTI PER INSERTI RAGGIATI BLADES - BLADES HOLDER - Z TOOL INSERTS - RADIUS INSERTS - RADIUS INSERT HOLDERS	97
CORAL		UTENSILI PER NON MARCARE NO MARKING TOOLS	107
MAGENTA		ADATTATORI PER TUTTE LE PRESSE ADAPTERS FOR ALL PRESS BRAKES	119
YELLOW		LAME CESCOIA SHEAR BLADES	137
GREEN		ACCESSORI PER TUTTE LE PRESSE ACCESSORIES FOR ALL PRESS BRAKES	139
SILVER		LAVORAZIONI MODIFICHE E RICONDIZIONAMENTO WORKING MODIFICATION REFURBISHED TOOLING	143
GOLD		UTENSILI SPECIALI PER TUTTE LE PRESSE SPECIAL TOOLING FOR ALL PRESS BRAKES	147

INDICE / INDEX

CODE	α	PAGE
10.115		104
10.116		104
10.136	60°	18
10.142	60°	17
10.143	60°	17
10.153	88°	14
10.155	88°	15
10.157	88°	15
10.170	85°	14
10.174	88°	14
10.176	88°	14
10.180		102
10.181		102
10.182		102
10.183		102
10.184		102
10.185		102
10.186		102
10.187		102
10.188		102
10.190		104
10.191		104
10.257	88°	14
10.260	88°	14
10.262	88°	14
10.264	88°	14
10.300		103
10.301		103
10.302		103
10.303		103
10.304		103
10.305		103
10.306		103
10.307		103
10.308		103
10.309		103
10.309		103
10.310		103
10.311		103
10.312		103
10.313		103
10.314		103
10.315		103
10.316		103
10.317		103
10.318		103
10.319		103

CODE	α	PAGE
10.320		103
10.321		103
10.322		103
10.323		103
10.324		103
10.325		103
10.400		98
10.500	60°	17
10.502	88°	15
10.504	88°	14
10.505	88°	17
10.506	60°	18
10.510	60°	18
10.511	30°	19
10.512	88°	15
10.514	30°	19
10.515	30°	19
10.516	60°	17
10.517	60°	18
10.520	60°	18
10.626	85°	14
10.672	85°	15
11.101	88°	14
11.102	45°	18
11.103	35°	19
11.104	35°	19
11.106	88°	15
11.108	88°	15
11.134	45°	18
11.145	88°	14
11.146	88°	15
11.147	88°	15
11.148	88°	15
11.149	88°	15
11.151	85°	15
11.158	30°	19
11.200	85°	14
11.201	85°	14
11.228	88°	14
11.230	85°	14
11.231	85°	14
11.232	85°	14
11.233	88°	17
11.235	88°	15
11.240	88°	17
11.257	88°	14
11.258	30°	19

CODE	α	PAGE
11.260	88°	14
11.270	85°	14
11.275	75°	14
11.280	30°	19
11.514	30°	19
11.528	30°	19
11.530	30°	19
11.540	26°	20
11.550	24°	39
11.554	24°	39
11.560	24°	39
11.600	35°	19
11.650	85°	14
11.660	85°	15
11.670	85°	15
11.680	85°	17
11.710	60°	18
11.720	60°	18
11.750	60°	18
11.780	30°	20
11.800	85°	16
11.810	30°	20
11.820	85°	17
11.830	88°	15
11.835	85°	17
11.840	85°	16
11.848	85°	15
11.849	85°	15
11.850	85°	16
11.853	85°	14
11.855	85°	14
11.857	85°	14
11.858	88°	14
11.861	85°	14
11.863	85°	15
11.864	85°	15
11.865	85°	15
11.866	85°	15
11.867	85°	15
11.868	85°	14
11.869	85°	17
11.870	88°	14
11.880	30°	20
11.904	30°	20
11.911	30°	20
11.914	30°	20
11.916	30°	20

CODE	α	PAGE
14.010	60°	67
14.020	80°	67
14.030	28°	67
14.040	86°	67
14.050	28°	67
14.060	80°	67
14.080		100
14.085		100
14.090		100
14.095		100
14.150	85°	69
14.151	85°	69
14.152	85°	69
14.153	30°	69
14.154	30°	69
14.155	30°	69
14.156	85°	69
14.157	60°	69
14.158	85°	70
14.159	85°	70
14.160	85°	70
14.161	30°	71
14.162	30°	71
14.163	30°	71
14.164	85°	71
14.165	60°	70
14.250		105
14.251		105
14.252		105
14.280		98
14.281		98
14.282		98
14.908	24°	77
14.910	24°	77
14.912	24°	77
15.010		104
15.014		104
15.018		104
15.050		100
15.310	60°	43
15.320	28°	45
15.330	86°	43
15.335	86°	43
15.370	86°	43
15.380	86°	43
15.450	28°	45
15.480	80°	43

INDICE / INDEX

CODE	α	PAGE
15.610	28°	45
15.620	28°	46
15.630	86°	43
15.635	86°	43
15.670	86°	43
15.680	60°	45
15.700	86°	44
15.710	86°	44
15.720	28°	46
15.730	60°	46
15.750	28°	46
15.755		98
15.760		98
15.761	28°	99
15.763	28°	99
15.765	28°	99
15.766	28°	99
15.767	28°	99
15.768	28°	99
15.769	28°	99
15.774	84°	99
15.776	86°	99
15.790	84°	44
15.800	86°	44
15.902	24°	53-63
15.904	24°	53-63
15.905	24°	53-63
16.010		104
16.050		100
16.060		100
16.070		98
16.200	78°	81
16.201	78°	81
16.202	26°	81
16.203	26°	82
16.204	26°	82
16.205	78°	82
16.206	78°	82
16.207	26°	82
16.208	26°	82
16.209	26°	82
17.010		104
17.050		100
17.070		98
17.510		105
17.550		100
17.570		98

CODE	α	PAGE
18.100	76°	93
19.021	28°	57
19.022	80°	57
19.023	86°	57
19.024	60°	57
19.031	28°	58
19.032	80°	58
19.033	86°	58
19.034	60°	58
19.224	86°	57
19.226	45°	57
19.233	80°	58
19.235	80°	58
20.200		30
20.201		30
20.204	88°	30
20.205	88°	30
20.210	85°	25
20.211	85°	25
20.212	85°	25
20.213	85°	26
20.214	85°	26
20.215	85°	26
20.216	80°	26
20.217	80°	26
20.229	60°	30
20.230	60°	30
20.231	26°	36
20.235	60°	30
20.264	35°	36
20.267	60°	30
20.271		113
20.272		113
20.273		113
20.274		113
20.278	88°	31
20.279	88°	31
20.280	88°	31
20.287		31
20.289		113
20.290		113
20.291		113
20.292		113
20.296	88°	30
20.297	60°	28
20.298	60°	28
20.299	60°	28

CODE	α	PAGE
20.300	60°	28
20.301	60°	28
20.303	30°	36
20.305	26°	36
20.306		30
20.308	60°	28
20.309	88°	28
20.310	88°	28
20.311	60°	28
20.316		30
20.317	30°	28
20.318	30°	28
20.319	30°	28
20.320	30°	28
20.321	30°	28
20.322	30°	28
20.323	30°	28
20.325	30°	25
20.327	88°	28
20.328	45°	28
20.329	45°	28
20.330	45°	28
20.331	45°	28
20.332	45°	28
20.333	45°	28
20.334	45°	28
20.336		31
20.338	88°	30
20.339	88°	31
20.344	85°	31
20.345	85°	31
20.346	85°	31
20.347	85°	31
20.348	85°	31
20.349	85°	31
20.350	60°	24
20.351	30°	29
20.352	30°	29
20.353	30°	29
20.354	30°	29
20.370	60°	25
20.371	88°	28
20.380	45°	26
20.382	88°	29
20.383	88°	29
20.384	88°	29
20.385	88°	29

CODE	α	PAGE
20.386	60°	29
20.387	60°	29
20.388	60°	29
20.389	60°	29
20.390	60°	29
20.391	60°	29
20.392	60°	29
20.393	45°	29
20.394	45°	29
20.395	45°	29
20.396	45°	29
20.397	45°	29
20.398	45°	29
20.399	45°	29
20.400		31
20.401	30°	29
20.402	30°	29
20.403	30°	29
20.406	35°	28
20.408	35°	28
20.410	35°	28
20.412	35°	28
20.416	35°	28
20.418	30°	30
20.420	35°	28
20.425	35°	28
20.438	30°	31
20.440	45°	25
20.450	30°	36
20.478	30°	31
20.484	45°	25
20.494	30°	25
20.506	85°	28
20.508	85°	28
20.510	85°	28
20.512	85°	28
20.516	85°	28
20.520	85°	28
20.525	85°	28
20.550		39
20.554		39
20.560		39
20.610	60°	26
20.650	60°	25
20.680	60°	26
20.701		111
20.703		111

INDICE / INDEX

CODE	α	PAGE
20.705		111
20.707		111
20.709		111
20.720		111
20.725		111
20.732		111
20.806	88°	28
20.808	88°	28
20.810	88°	28
20.820	85°	24
20.830	30°	24
21.125	80°	27
21.160	80°	27
21.200	70°	27
21.202	88°	30
21.207	85°	24
21.209		24
21.231	26°	37
21.264	35°	37
21.275	88°	31
21.276	88°	31
21.280		113
21.289		113
21.290		113
21.291		113
21.292		113
21.303	30°	37
21.305	26°	37
21.406	35°	29
21.408	35°	29
21.410	35°	29
21.412	35°	29
21.416	35°	29
21.420	35°	29
21.425	35°	29
21.450	30°	37
21.506	85°	29
21.508	85°	29
21.510	85°	29
21.512	85°	29
21.516	85°	29
21.520	85°	29
21.525	85°	29
21.806	88°	29
21.808	88°	29
21.810	88°	29
22.001		114

CODE	α	PAGE
22.002		114
22.003		114
22.004		114
22.005		114
22.010		32
22.020		32
22.306	30°	33
22.308	30°	33
22.310	30°	33
22.312	30°	33
22.316	30°	33
22.320	30°	33
22.325	30°	33
22.432	45°	33
22.440	45°	33
22.606	60°	33
22.608	60°	33
22.610	60°	33
22.612	60°	33
22.616	60°	33
22.620	60°	33
22.625	60°	33
22.804	88°	33
22.806	88°	33
22.808	88°	33
22.810	88°	33
22.812	88°	33
22.816	88°	33
22.820	88°	33
22.825	88°	33
22.832	84°	33
22.840	84°	33
24.017	30°	74
24.018	30°	74
24.040	60°	74
24.050	60°	74
24.060	60°	74
24.080	80°	74
24.120	80°	74
24.180	80°	74
24.306	30°	74
24.308	30°	74
24.310	30°	74
24.312	30°	74
24.320	30°	74
24.332	30°	74
25.100	86°	49

CODE	α	PAGE
25.101	86°	49
25.102	86°	49
25.103	86°	49
25.104	86°	49
25.105	86°	49
25.106	86°	49
25.107	86°	49
25.108	86°	49
25.109	86°	49
25.110	86°	49
25.111	80°	49
25.112	80°	49
25.113	80°	49
25.114	80°	49
25.115	80°	49
25.116	60°	49
25.200	84°	49
25.201	84°	49
25.202	84°	49
25.203	84°	49
25.204	84°	49
25.205	84°	49
25.206	84°	49
25.207	80°	49
25.208	80°	49
25.209	80°	49
25.210	80°	49
25.300	84°	49
25.301	84°	49
25.302	84°	49
25.303	84°	49
25.304	84°	49
25.350	86°	49
25.400	30°	49
25.401	30°	49
25.402	30°	49
25.403	30°	49
25.404	30°	49
25.405	30°	49
25.406	30°	49
25.407	30°	49
25.408	30°	49
25.409	30°	49
25.410	30°	49
25.421	30°	49
25.422	30°	49
25.423	30°	49

CODE	α	PAGE
25.424	30°	49
25.425	30°	49
25.500	30°	49
25.501	30°	49
25.502	30°	49
25.503	30°	49
25.504	30°	49
25.601	86°	50
25.602	86°	50
25.603	86°	50
25.604	86°	50
25.605	86°	50
25.606	86°	50
25.607	86°	50
25.621	84°	50
25.622	84°	50
25.623	84°	50
25.624	84°	50
25.625	84°	50
25.626	84°	50
25.627	80°	50
25.628	80°	50
25.629	80°	50
25.630	80°	50
25.901	30°	50
25.902	30°	50
25.903	30°	50
25.904	30°	50
25.905	30°	50
25.906	30°	50
25.907	30°	50
25.908	30°	50
25.909	30°	50
25.992		53-63-77
25.994		53-63-77
25.995		53-63-77
26.005		114
26.200	30°	84
26.201	30°	84
26.202	30°	84
26.203	30°	84
26.204	30°	84
26.205	30°	84
26.206	30°	84
26.207	30°	84
26.208	30°	84
26.209	30°	84

INDICE / INDEX

CODE	α	PAGE
26.211	78°	84
26.212	78°	84
26.213	78°	84
26.214	78°	84
26.215	78°	84
26.216	78°	84
26.217	78°	84
26.218	78°	84
26.219	78°	84
26.220	78°	84
26.221	78°	84
26.222	78°	84
26.223	78°	84
26.250	30°	84
26.251	30°	84
26.252	30°	84
26.253	30°	84
26.254	30°	84
26.255	30°	84
26.256	30°	84
26.257	30°	84
26.258	30°	84
26.259	30°	84
26.260	30°	84
26.262	78°	84
26.263	78°	84
26.264	78°	84
26.265	78°	84
26.266	78°	84
26.267	78°	84
26.268	78°	84
26.269	78°	84
26.270	78°	84
26.271	78°	84
26.272	78°	84
26.273	78°	84
26.274	78°	84
26.275	78°	84
28.100	80°	94
28.820	60°-80°	94
29.000	40°	109
29.100	60°	109
29.150	60°	109
29.200	60°	109
29.300	60°	109
29.510	86°	60
29.511	86°	60

CODE	α	PAGE
29.512	86°	60
29.513	80°	60
29.514	80°	60
29.515	80°	60
29.517	80°	60
29.521	86°	60
29.522	86°	60
29.523	86°	60
29.524	86°	60
29.535	80°	60
29.551	30°	60
29.552	30°	60
29.553	30°	60
29.554	30°	60
29.561	30°	60
29.562	30°	60
29.563	30°	60
31.306	30°	115
31.308	30°	115
31.406	45°	115
31.408	45°	115
31.410	45°	115
31.606	60°	115
31.608	60°	115
31.610	60°	115
31.806	88°	115
31.808	88°	115
31.810	88°	115
32.306	30°	115
32.308	30°	115
32.310	30°	115
32.406	45°	115
32.408	45°	115
32.410	45°	115
32.412	45°	115
32.606	60°	115
32.608	60°	115
32.610	60°	115
32.612	60°	115
32.616	60°	115
32.806	88°	115
32.808	88°	115
32.810	88°	115
32.812	88°	115
32.816	88°	115
33.306	30°	115
33.308	30°	115

CODE	α	PAGE
33.310	30°	115
33.312	30°	115
33.316	30°	115
33.406	45°	115
33.408	45°	115
33.410	45°	115
33.412	45°	115
33.416	45°	115
33.420	45°	115
33.606	60°	115
33.608	60°	115
33.610	60°	115
33.612	60°	115
33.616	60°	115
33.620	60°	115
33.806	88°	115
33.808	88°	115
33.810	88°	115
33.812	88°	115
33.816	88°	115
33.820	88°	115
33.825	88°	115
40.002		103
40.003		102
40.010		140
40.015		141
40.016		141
40.111		22
40.113		22
40.114		22
40.115		22
40.116		22
40.121		22
40.122		22
40.124		22
40.146		141
40.157		141
40.260		141
40.419		100
40.500		101
40.510		101
40.511		101
40.515		101
40.516		101
40.520		101
40.521		101
40.525		101

CODE	α	PAGE
40.526		101
40.530		101
40.535		101
40.540		101
40.545		101
40.550		101
40.555		101
40.560		101
40.570		101
40.575		101
40.580		101
40.585		101
40.590		101
40.610		101
40.611		101
40.612		101
40.613		101
40.614		101
40.615		101
40.645		142
40.650		142
40.651		142
40.652		142
40.653		142
40.660		140
40.670	88°	22
40.680	85°	22
40.700		140
40.740		140
40.745		140
40.750		140
40.800		117
40.810		116
40.815		116
40.820		116
40.830		116
40.835		116
40.840		116
40.845		116
40.850		117
40.860		117
50.200		127
50.210		127
50.220		127
50.250		127
50.310		129
50.400		123

INDICE / INDEX

CODE	α	PAGE
50.410		122
50.415		122
50.430		122
50.440		122
50.445		122
50.450		122
50.470		123
50.490		123
50.500		125
50.501		125
50.502		126
50.503		126
50.512		121
50.529		128
50.551		128
50.571		128
50.574		129
50.577		129
50.600		135
50.610		135
50.615		135
50.635		135
50.640		135
50.645		135
50.646		135
50.650		136
50.651		136
50.657		135
50.666		121
50.667		121
50.668		121
50.669		121
50.671		122
50.673		121
50.674		121
50.680		121
50.685		135
50.693		129
50.697		129
50.705		121
50.706		121
50.707		121
50.708		121
50.710		121
50.712		129
50.720		37
50.725		135

CODE	α	PAGE
50.730		135
50.731		135
50.800		134
50.805		134
50.810		134
50.820		134
50.825		134
50.830		134
50.835		134
50.870		134
50.875		134
50.890		134
50.900		128
50.903		128
50.905		128
50.910		128
50.930		93-125
50.930		125
50.935		93-125
50.935		125
50.940		122
50.945		127
50.950		87-124
50.950		124
50.959		122
50.960		123
50.970		122
50.971		122
50.972		127
50.980		123
50.981		123
50.982		123
50.983		123
50.985		123
50.990		124
50.991		124
50.991		124
50.993		124
50.994		124
50.996		124
50.997		124
50.998		124
60.100		146
60.120		54
60.130		54
60.150		146
60.200		146

CODE	α	PAGE
60.617		141
60.618		141
60.619		141
60.680		120
60.681		120
60.682		120
60.683		120
60.685		136
60.710		133
60.715		133
60.720		133
60.725		133
60.730		133
60.735		133
60.910		110
60.910		130
60.919		130
60.920		110
60.920		130
60.925		130
60.930		130
60.935		110
60.935		130
60.940		110
60.940		130
60.945		131
60.950		110
60.950		130
60.955		131
60.960		130
60.961		136
60.965		131
60.980		87-123
60.980		131
63.000		136
63.001		136
63.012		136
63.121		136
63.122		136
63.123		136
63.124		136
63.126		136
63.127		136
63.128		136
63.129		136
70.010		144
70.015		144

CODE	α	PAGE
70.020		144
70.025		144
70.030		144
70.035		144
70.040		144
70.050		146
70.060		146
70.070		146
70.100		36
70.102		36
70.120		37
70.121		37
70.123		37
70.130		43-57-82
70.500		12-144
70.501		12-144
70.502		12-144
70.504		12-144
70.600		12-144
70.714		42-56-81
70.715		42-56-81
70.716		42-56
70.717		42-56
70.718		42-56-81
70.719		42-56
70.800		54
70.810		54
70.900		146
70.946		12-144
70.947		12-144
70.948		12-144
70.949		12-144
71.100		128
70.1050		12-144
800.000		120
810.000		120
820.000		120

TABELLA DI PIEGATURA / BENDING CHART

FORZA NECESSARIA PER PIEGA A 90° IN ARIA DI LAMIERA CON RESISTENZA
 FORCE REQUIRED FOR 90° AIR BENDING, SHEET RESISTANCE

R=45 Kg/mmq

T mm	6	8	10	12	16	20	25	32	40	50	63	80	100	125	160	200	250	V
	4	5.5	7	8.5	11	14	17.5	22	28	35	45	55	71	89	113	140	175	B
	1	1.3	1.6	2	2.6	3.3	4	5	6.5	8	10	13	16	20	26	33	41	Ri
0.5	3																	
0.6	4	4																
0.8	7	5	4															
1	11	8	7	6														
1.2	16	12	10	8	6													
1.5		17	15	13	9	8												
2			27	22	17	13	11											
2.5				35	26	21	17	13										
3					38	30	24	19	15									
4						54	42	34	27	21								
5							67	52	42	33	26							
6								75	60	48	38	30						
8									107	85	68	53	43					
10										134	105	85	67	53				
12											153	120	96	78	60			
15												188	150	120	95	75		
20													270	215	170	135	108	F t/m

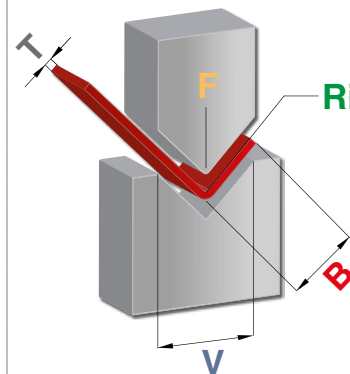

SPESSORE LAMIERA IN MM

THICKNESS OF THE SHEET IN MM

FORZA IN TON /METRO

FORCE IN TON / METER

RAGGIO INTERNO

INSIDE RADIUS

BORDO MINIMO POSSIBILE

MINIMUM FLANGE LENGHT

LARGHEZZA DEL V

V-OPENING

T

F

Ri

B

V

ALLUMINIO

ALUMINIUM

R=20-25 KG/MMQ

ACCIAIO DOLCE

MILD STEEL

R=40-45 KG/MMQ

INOX

STAINLESS STEEL

R=65-70 KG/MMQ

CALCOLO DELLA FORZA PER PIEGA IN ARIA

CALCULATION OF FORCE FOR AIR BENDING

$$F = \frac{T^2 \times 2 \times Ri}{1.4 \times V} = \dots\dots\dots \text{Tons/mt}$$

RAPPORTO TRA SPESSORE DI LAMIERA E AMPIEZZA DEL V
 SHEET THICKNESS / V - WIDTH

SPESSORE LAMIERA (mm)
 SHEET THICKNESS (mm)

0.5 - 2.5

3 - 8

9 - 10

12 OR MORE

AMPIEZZA DEL V (mm)
 V - WIDTH (mm)





6 T

8 T

10 T

12 T

LEGENDA DEI MATERIALI MATERIAL SPECIFICATIONS

	ACCIAIO C45 (UNI EN 10083 W.1. : 1.1191). STEEL C45 (UNI EN 10083 W.1. : 1.1191).
	ACCIAIO C45 (UNI EN 10083 W.1. : 1.1191) TEMPRATO AD INDUZIONE (52/55 HRC) SULLE PARTI USURABILI. STEEL C45 (UNI EN 10083 W.1. : 1.1191) INDUCTION TEMPERED (52-55 HRC) ON WEAR PARTS.
	ACCIAIO C45 (UNI EN 10083 W.1. : 1.1191) BONIFICATO R=80-85 KG/MMQ TEMPRATO AD INDUZIONE (52/55 HRC) SULLE PARTI USURABILI. STEEL C45 (UNI EN 10083 W.1. : 1.1191) HARDENED R=80-85 KG/MMQ INDUCTION TEMPERED (52-55 HRC) ON WEAR PARTS.
	ACCIAIO 42CRMO4 (UNI EN 10083 W.1. : 1.7225) BONIFICATO R=95-105 KG/MMQ TEMPRATO AD INDUZIONE (52/55 HRC) SULLE PARTI USURABILI. STEEL 42 CRMO4 (UNI EN 10083 W.1. : 1.7225) HARDENED R=95-105 KG/MMQ INDUCTION TEMPERED (52-55 HRC) ON WEAR PART.

TRATTAMENTI TERMICI HARDENED TREATMENT	GLI UTENSILI STANDARD E SPECIALI SONO TEMPRATI AD INDUZIONE SULLE PARTI USURABILI A 52-55 HRC. THE STANDARD AND SPECIAL TOOLS ARE INDUCTION HARDENED TO 52-55 HRC ON WEAR PARTS.
TRATTAMENTI ANTIUSURA ANTIWEAR TREATMENT	A RICHIESTA DEL CLIENTE, SUGLI UTENSILI COSTRUITI IN 42CRM04, PUÒ ESSERE FATTO UN TRATTAMENTO ANTIUSURA DI NITRURAZIONE. ON REQUEST ON THE TOOLING IN 42CRM04 TECNOSTAMP CAN MAKE AN ANTIWEAR-NITRIDING TREATMENT.
TRATTAMENTI ANTIRUGGINE RUSTING TREATMENT	A RICHIESTA DEL CLIENTE SUGLI UTENSILI PUÒ ESSERE FATTO IL TRATTAMENTO ANTI RUGGINE DI ZINCATURA. AN ANTI RUST-GALVANIZED TREATMENT CAN BE MADE ON TOOLS ON REQUEST.

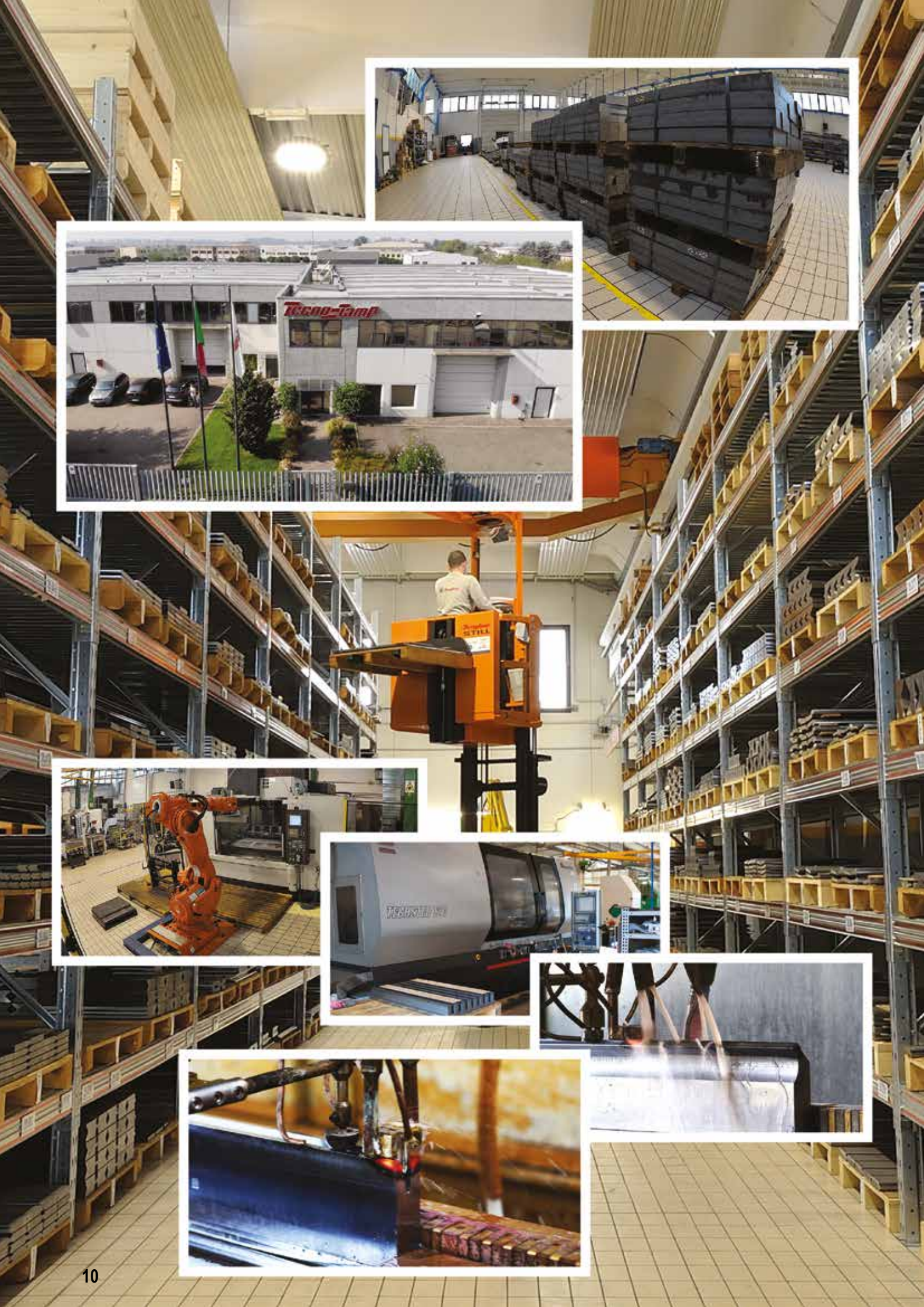

AMADA - PROMECAM STYLE

PUNZONI

PUNCHES



RED LINE

AMADA - PROMECAM STYLE



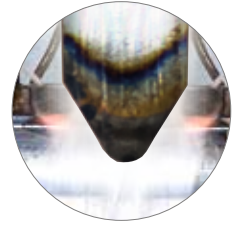
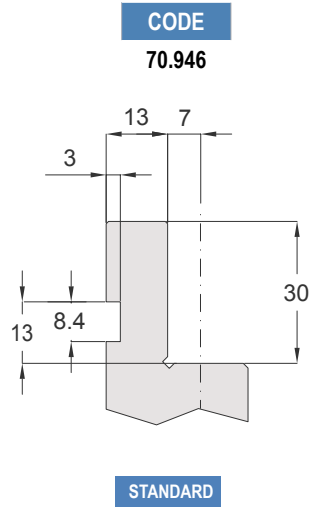
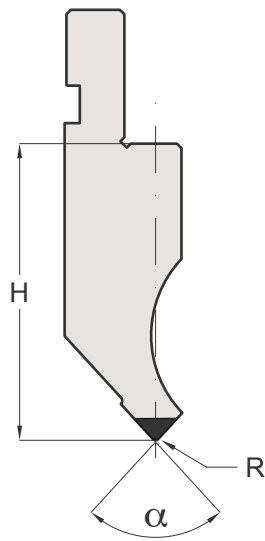

TEMPRA AD INDUZIONE 52-55 HRC
INDUCTION HARDENED 52-55 HRC

LEGENDA	α = ANGOLO	R = RAGGIO	H = ALTEZZA
LEGEND	α = ANGLE	R = RADIUS	H = HEIGHT

SCANALATURA DI SICUREZZA SU RICHIESTA
SAFETY GROOVE ON REQUEST

<p>CODE 70.500</p> <p>EURO - BEYELER</p>	<p>CODE 70.501</p> <p>EUROBEYELER - EURO WILA</p>	<p>CODE 70.502</p> <p>DONEWELL - SAFAN - EUROBEYELER</p>	<p>CODE 70.504</p> <p>AMADA ONE TOUCH</p>	<p>CODE 70.600</p> <p>GASPARINI</p>
<p>CODE 70.946</p> <p>AMADA / PROMECAM</p>	<p>CODE 70.947</p> <p>COLGAR OLD STYLE</p>	<p>CODE 70.948</p> <p>AMADA OLD STYLE</p>	<p>CODE 70.949</p> <p>AMADA - BMB IDRAULIC</p>	<p>CODE 70.1050</p> <p>AMADA - PROMECAM (CLARK)</p>

PUNZONI / PUNCHES *AMADA - PROMECAM STYLE*

I PUNZONI STANDARD SONO DISPONIBILI A MAGAZZINO NELLE LUNGHEZZE DI: 415 / 835 E FRAZIONATI (805 mm)
 THE PUNCHES ARE AVAILABLE IN THE FOLLOWING STANDARD LENGTHS: 415 / 835 AND SECTIONED (805 mm)

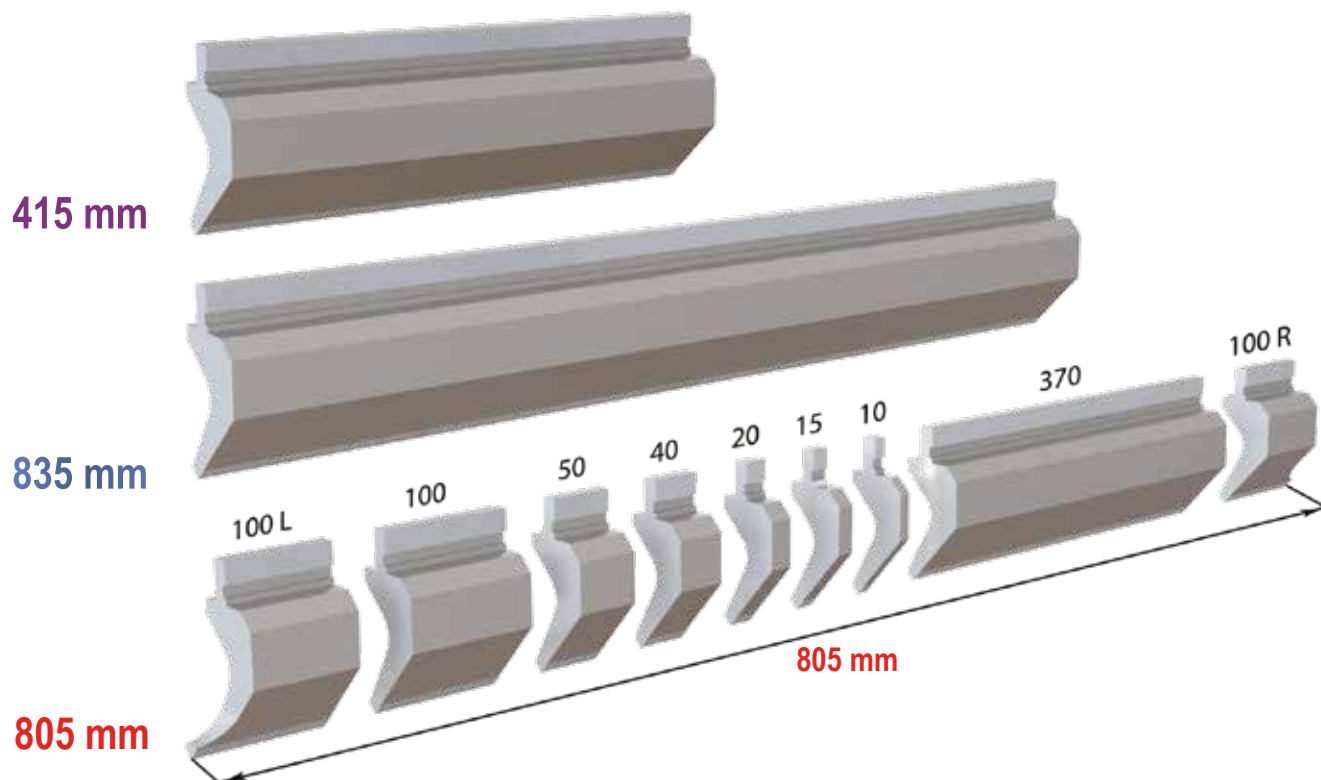

IL CARICO MASSIMO DELLE SCARPETTE CORRISPONDE AL 50% DEL CARICO MASSIMO INDICATO SUL PUNZONE.
 THE MAX LOAD OF THE HORN EXTENSIONS IS 50% OF THE MAX LOAD OF THE PUNCH.

CODE							
10.142	10.262	10.517	11.235	11.228	11.260	11.800	11.858
10.143	10.264	10.520	11.146	11.230	11.270	11.867	11.861
10.153	10.500	10.626	11.147	11.231	11.275	11.868	11.863
10.155	10.502	10.672	11.148	11.232	11.280	11.840	11.864
10.157	10.504	11.101	11.149	11.233	11.650	11.850	11.865
10.170	10.505	11.106	11.151	11.835	11.660	11.853	11.866
10.174	10.506	11.108	11.200	11.240	11.670	11.855	11.869
10.176	10.510	11.145	11.201	11.257	11.680	11.857	11.870

CODE						
10.136	10.515	11.134	11.528	11.710	11.810	11.904
10.511	11.102	11.158	11.530	11.720	11.820	11.911
10.512	11.103	11.258	11.540	11.750	11.830	11.914
10.514	11.104	11.514	11.600	11.780	11.880	11.916

PUNZONI / PUNCHES *AMADA - PROMECAM STYLE* 75° / 85° / 88°

CODE	α	R	H	T/Mt	Mt
11.101	88°	3.00	65.45	100	■
11.145	88°	0.80	66.50	100	■
10.153	88°	0.25	66.50	100	■
11.201	85°	3.00	65.45	100	■
11.200	85°	0.80	66.50	100	■
11.853	85°	0.25	66.50	100	■
11.275	75°	0.80	67.60	100	■

415 mm
835 mm
805 mm SECTIONED

CODE	α	R	H	T/Mt	Mt
10.176	88°	0.60	66.74	35	■
10.174	88°	0.25	66.70	35	■
10.170	85°	0.60	66.74	35	■
11.857	85°	0.25	67.00	35	■

415 mm
835 mm
805 mm SECTIONED

CODE	α	R	H	T/Mt	Mt
11.870	88°	0.80	135.00	100	■
11.232	85°	0.80	135.00	100	■

415 mm
835 mm
805 mm SECTIONED

CODE	α	R	H	T/Mt	Mt
11.228	88°	0.80	105.00	100	■
11.231	85°	3.00	105.00	100	■
11.230	85°	0.80	105.00	100	■

415 mm
835 mm
805 mm SECTIONED

CODE	α	R	H	T/Mt	Mt
10.262	88°	0.60	100.00	50	■
10.264	88°	0.25	100.00	50	■
11.861	85°	0.60	100.00	50	■
10.626	85°	0.25	100.00	50	■

415 mm
835 mm
805 mm SECTIONED

CODE	α	R	H	T/Mt	Mt
11.858	88°	0.60	135.00	40	■
11.855	85°	0.60	135.00	40	■

415 mm
835 mm
805 mm SECTIONED

CODE	α	R	H	T/Mt	Mt
11.260	88°	0.60	95.00	50	■
11.257	88°	0.25	95.00	50	■
11.270	85°	0.60	95.00	50	■

415 mm
835 mm
805 mm SECTIONED

CODE	α	R	H	T/Mt	Mt
10.260	88°	0.60	95.00	50	■
10.257	88°	0.25	95.00	50	■

415 mm
835 mm NON FRAZIONABILE NOT SECTIONABLE

CODE	α	R	H	T/Mt	Mt
10.504	88°	0.80	104.50	50	■
11.650	85°	0.80	104.50	50	■
11.868	85°	0.25	104.70	50	■

415 mm
835 mm
805 mm SECTIONED

PUNZONI / PUNCHES *AMADA - PROMECAM STYLE* 85° / 88°

CODE	α	R	H	T/Mt	Mt
10.502	88°	0.80	89.70	50	■
11.865	85°	0.80	89.70	50	■
10.672	85°	0.25	90.00	50	■

415 mm
835 mm
805 mm SECTIONED

CODE	α	R	H	T/Mt	Mt
11.108	88°	3.00	103.50	50	■
11.147	88°	0.80	104.50	50	■
10.157	88°	0.25	104.50	50	■
11.866	85°	3.00	103.50	50	■
11.151	85°	0.80	104.50	50	■
11.867	85°	0.25	104.50	50	■

415 mm
835 mm
805 mm SECTIONED

CODE	α	R	H	T/Mt	Mt
11.106	88°	3.00	88.50	60	■
11.146	88°	0.80	89.58	60	■
10.155	88°	0.25	89.60	60	■
11.863	85°	3.00	88.50	60	■
11.660	85°	0.80	89.58	60	■
11.864	85°	0.25	89.70	60	■

415 mm
835 mm
805 mm SECTIONED

CODE	α	R	H	T/Mt	Mt
11.235	88°	1.00	120.00	100	■

415 mm
835 mm
805 mm SECTIONED

CODE	α	R	H	T/Mt	Mt
11.670	85°	0.80	145.00	60	■

415 mm
835 mm
805 mm SECTIONED

CODE	α	R	H	T/Mt	Mt
11.149	88°	0.80	165.00	60	■
11.849	85°	0.80	165.00	60	■

415 mm
835 mm
805 mm SECTIONED

CODE	α	R	H	T/Mt	Mt
11.148	88°	0.80	145.00	70	■
11.848	85°	0.80	145.00	70	■

415 mm
835 mm
805 mm SECTIONED

CODE	α	R	H	T/Mt	Mt
10.512	88°	0.60	84.13	20	■

415 mm
835 mm
805 mm SECTIONED

CODE	α	R	H	T/Mt	Mt
11.830	88°	0.60	85.00	15	■

415 mm
835 mm
805 mm SECTIONED

PUNZONI / PUNCHES *AMADA - PROMECAM STYLE* 85°

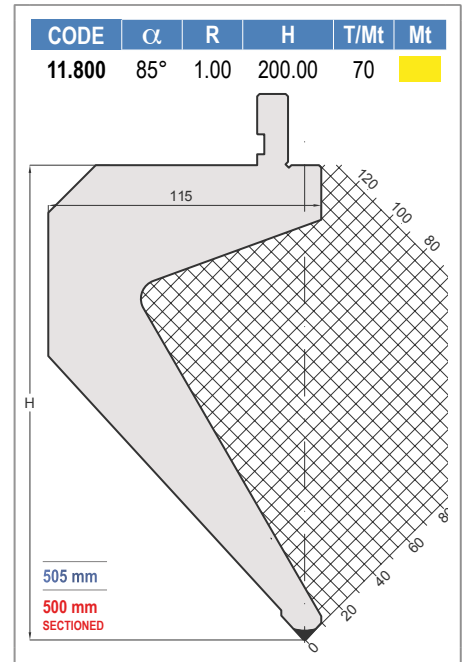
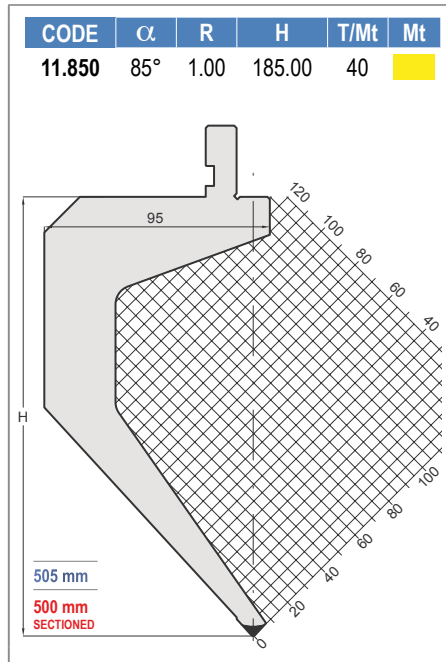
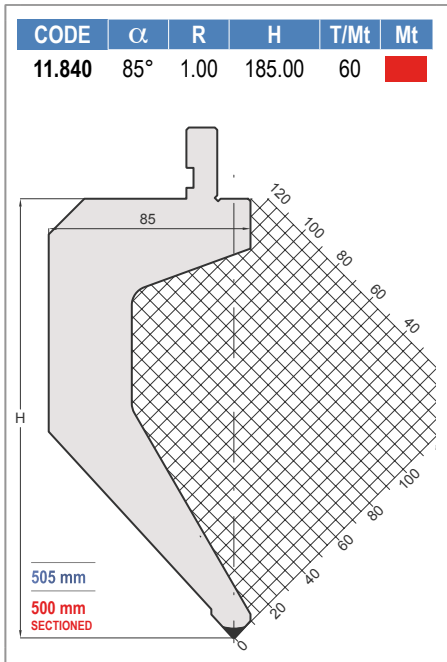

505 mm

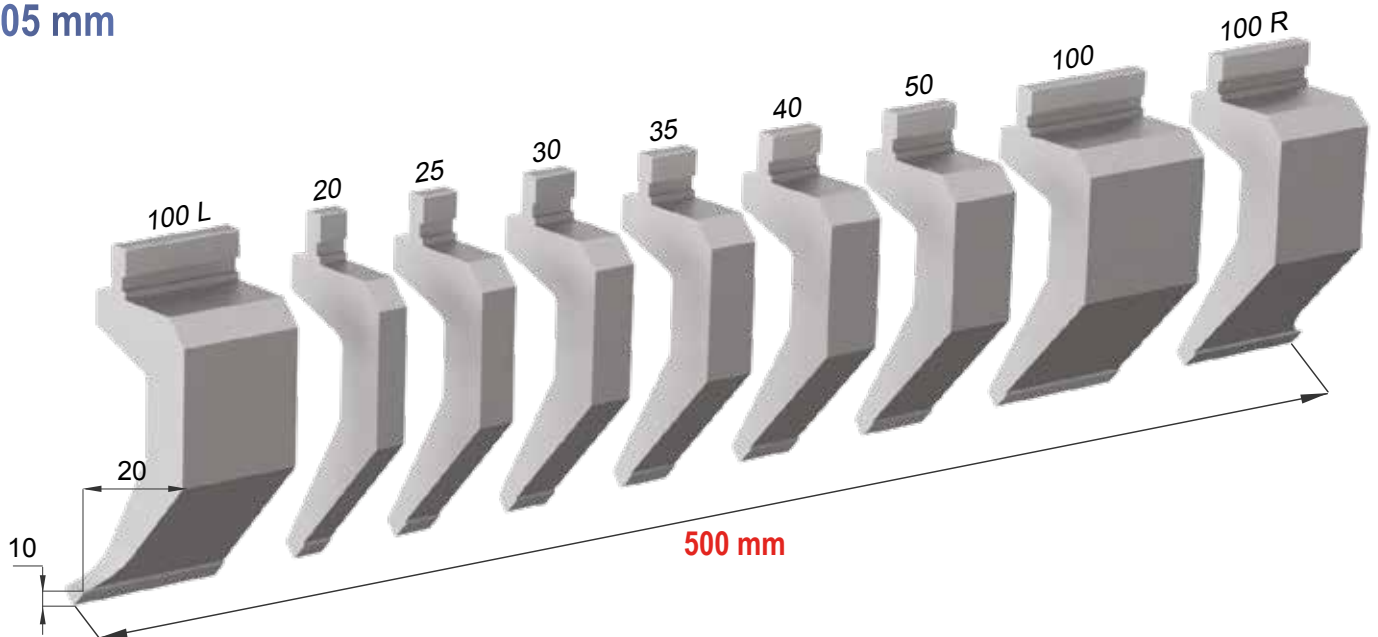

500 mm

IL CARICO MASSIMO DELLE SCARPETTE CORRISPONDE AL 50% DEL CARICO MASSIMO INDICATO SUL PUNZONE.
 THE MAX LOAD OF THE HORN EXTENSIONS IS 50% OF THE MAX LOAD OF THE PUNCH.

PUNZONI / PUNCHES *AMADA - PROMECAM STYLE* 60° / 85° / 88°

CODE	α	R	H	T/Mt	Mt
10.505	88°	0.80	120.00	50	■
11.835	85°	0.80	120.00	50	■

415 mm
835 mm
805 mm SECTIONED

CODE	α	R	H	T/Mt	Mt
11.820	85°	0.60	115.00	20	■

415 mm
835 mm
805 mm SECTIONED

CODE	α	R	H	T/Mt	Mt
11.680	85°	0.80	145.00	25	■

415 mm
835 mm
805 mm SECTIONED

CODE	α	R	H	T/Mt	Mt
11.240	88°	0.80	66.50	80	■

415 mm
835 mm
805 mm SECTIONED

CODE	α	R	H	T/Mt	Mt
11.233	88°	0.80	105.00	45	■
11.869	85°	0.80	105.00	45	■

415 mm
835 mm
805 mm SECTIONED



CODE	α	R	H	T/Mt	Mt
10.516	60°	0.80	85.00	40	■

415 mm
835 mm
805 mm SECTIONED

CODE	α	R	H	T/Mt	Mt
10.143	60°	2.00	65.80	60	■
10.142	60°	0.80	67.00	60	■

415 mm
835 mm
805 mm SECTIONED

CODE	α	R	H	T/Mt	Mt
10.500	60°	0.80	115.00	40	■

415 mm
835 mm
805 mm SECTIONED

PUNZONI / PUNCHES *AMADA - PROMECAM STYLE* 45° / 60°

CODE	α	R	H	T/Mt	Mt
10.506	60°	0.80	130.00	40	■

415 mm
835 mm
805 mm SECTIONED

CODE	α	R	H	T/Mt	Mt
10.517	60°	0.80	80.00	25	■

415 mm
835 mm
805 mm SECTIONED

CODE	α	R	H	T/Mt	Mt
10.510	60°	0.80	115.00	60	■

415 mm
835 mm
805 mm SECTIONED

CODE	α	R	H	T/Mt	Mt
10.520	60°	0.80	115.00	50	■

415 mm
835 mm
805 mm SECTIONED

CODE	α	R	H	T/Mt	Mt
11.750	60°	0.80	135.00	70	■

415 mm
835 mm
805 mm SECTIONED

CODE	α	R	H	T/Mt	Mt
10.136	60°	6.00	65.00	100	■

415 mm
835 mm
805 mm SECTIONED

CODE	α	R	H	T/Mt	Mt
11.710	60°	5.00	115.00	100	■

415 mm
835 mm
805 mm SECTIONED

CODE	α	R	H	T/Mt	Mt
11.720	60°	10.00	115.00	100	■

415 mm
835 mm
805 mm SECTIONED

CODE	α	R	H	T/Mt	Mt
11.134	45°	0.60	66.30	80	■
11.102	45°	1.00	65.20	80	■

415 mm
835 mm
805 mm SECTIONED

CODE	α	R	H	T/Mt	Mt
11.104	35°	1.50	86.00	70	■
11.600	35°	0.80	90.00	70	■
11.103	35°	0.60	86.00	70	■

415 mm
835 mm
805 mm SECTIONED

CODE	α	R	H	T/Mt	Mt
10.514	30°	0.60	80.00	50	■

415 mm
835 mm
805 mm SECTIONED

CODE	α	R	H	T/Mt	Mt
11.514	30°	0.60	104.00	50	■

415 mm
835 mm
805 mm SECTIONED

CODE	α	R	H	T/Mt	Mt
11.258	30°	0.60	104.00	100	■

415 mm
835 mm
805 mm SECTIONED

CODE	α	R	H	T/Mt	Mt
11.158	30°	0.60	80.00	100	■

415 mm
835 mm
805 mm SECTIONED

CODE	α	R	H	T/Mt	Mt
10.511	30°	3.00	80.00	100	■

415 mm
835 mm
805 mm SECTIONED

CODE	α	R	H	T/Mt	Mt
11.530	30°	5.00	104.00	100	■
11.528	30°	3.00	104.00	100	■

415 mm
835 mm
805 mm SECTIONED

CODE	α	R	H	T/Mt	Mt
10.515	30°	0.60	140.00	50	■

415 mm
835 mm
805 mm SECTIONED

CODE	α	R	H	T/Mt	Mt
11.280	30°	0.60	95.00	50	■

415 mm
835 mm
805 mm SECTIONED

PUNZONI / PUNCHES *AMADA - PROMECAM STYLE* 26° / 30°

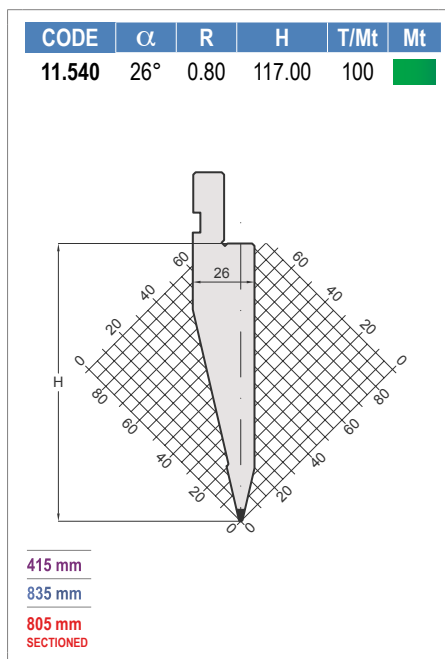
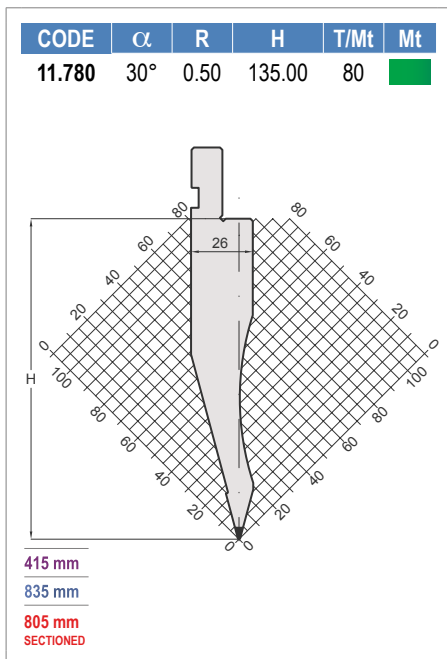
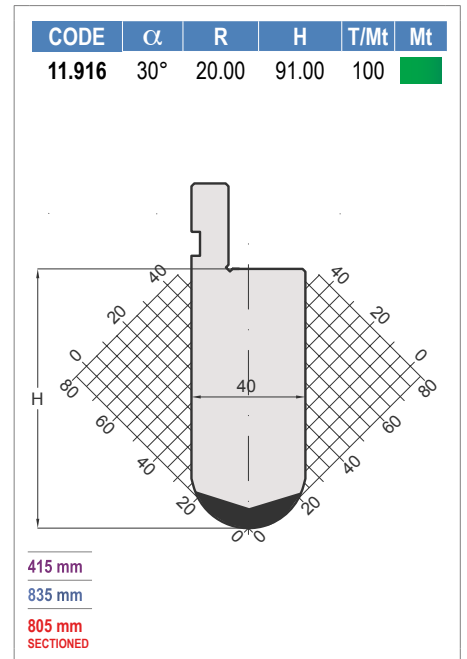
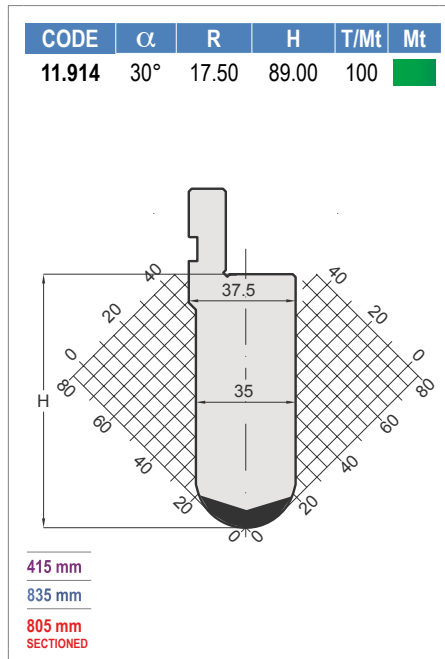
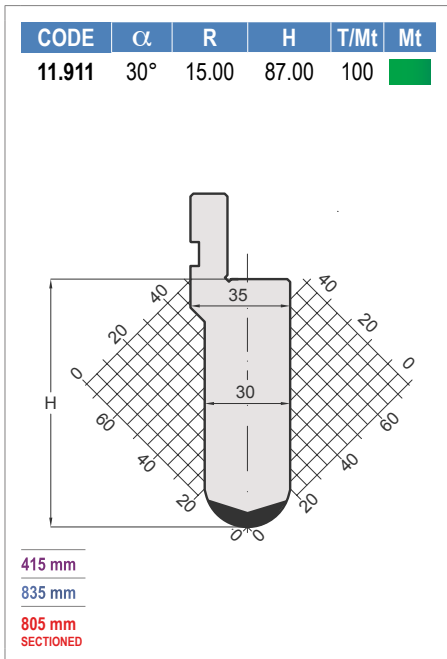
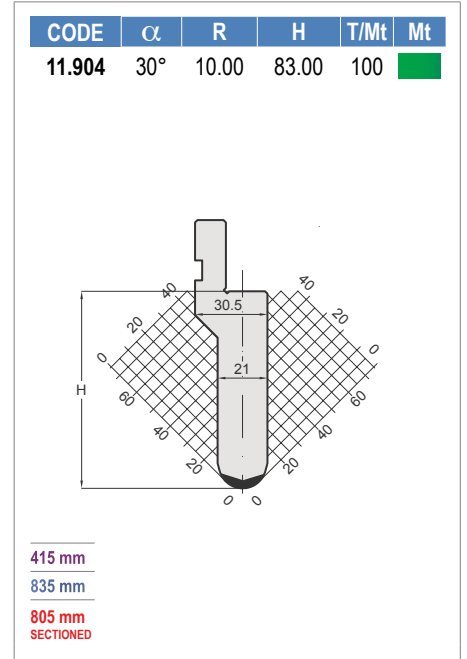
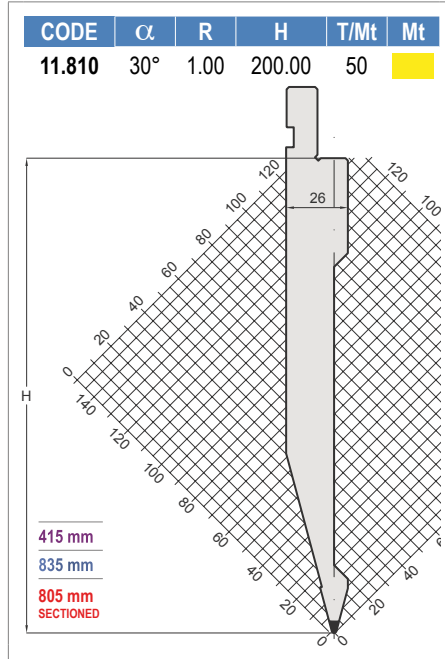
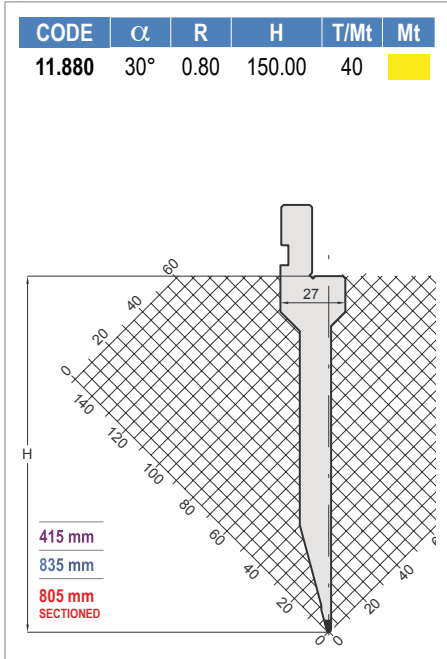

AMADA - PROMECAM STYLE

PUNZONE ROTANTE
E SCARPETTE MOBILI

ROTARY PUNCH
AND MOVING HORNS

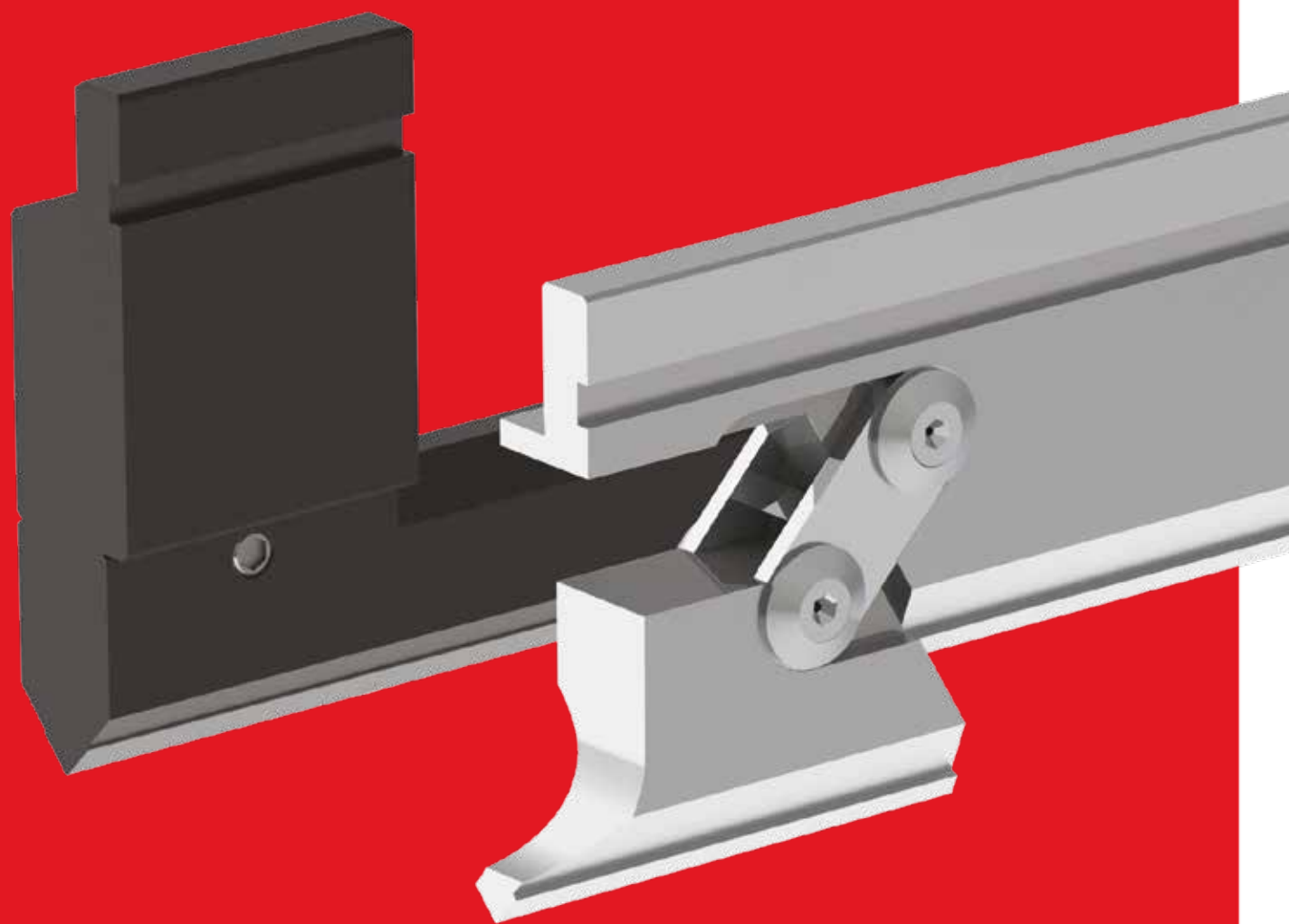

RED LINE

AMADA - PROMECAM STYLE



PUNZONE ROTANTE / ROTARY PUNCH *AMADA - PROMECAM STYLE*

CODE	α	R	H	T/Mt	Mt
40.670	88°	0.80	110.00	15	
40.680	85°	0.80	110.00	15	

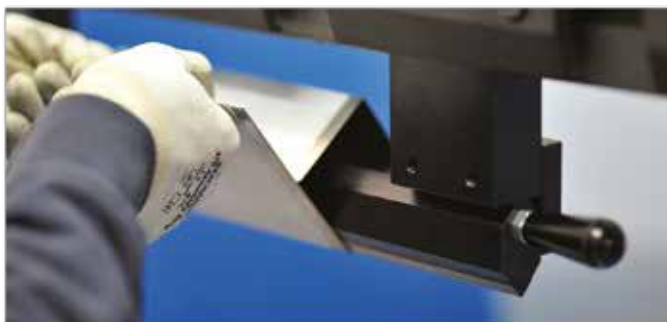
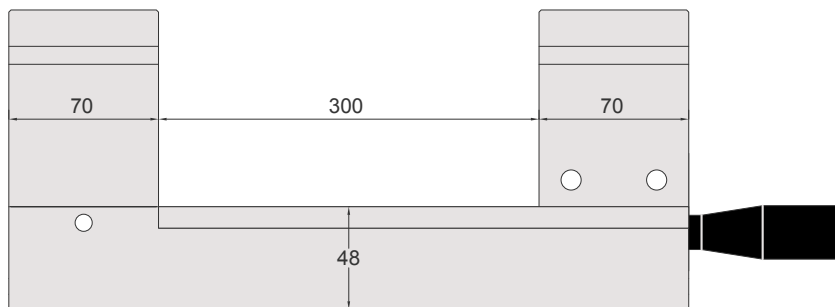
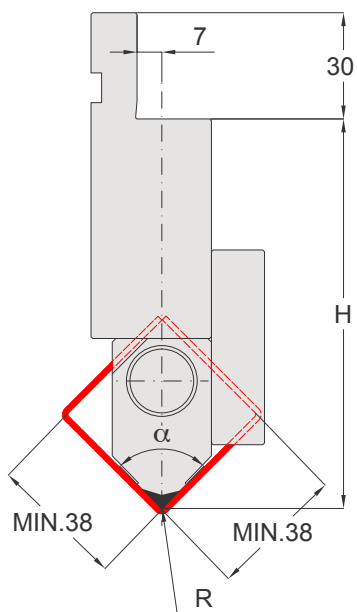

SCARPETTE MOBILI / MOVING HORNS *AMADA - PROMECAM STYLE*

SCARPETTE MOBILI
MOVING HORNS

PUNZONI
PUNCHES

40.111	➔	10.153
40.113	➔	11.145
40.114	➔	11.200
40.115	➔	11.101
40.116	➔	11.201
40.121	➔	10.176
40.122	➔	10.170
40.124	➔	10.174

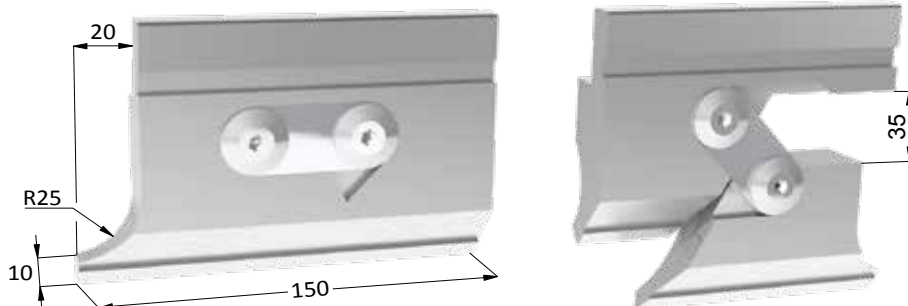

IL CARICO MASSIMO DELLE SCARPETTE CORRISPONDE AL 50% DEL CARICO MASSIMO INDICATO SUL PUNZONE.
THE MAX LOAD OF THE HORN EXTENSIONS IS 50% OF THE MAX LOAD OF THE PUNCH.

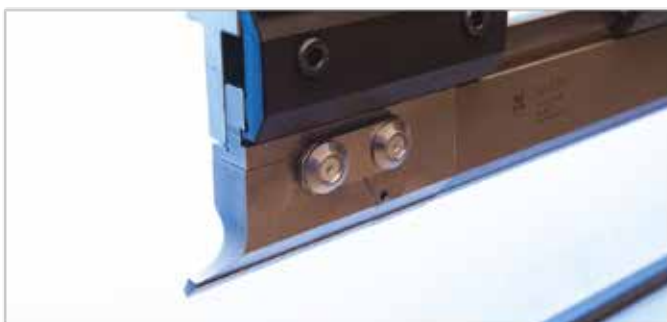

ADATTE ALL'ESECUZIONE DI SCATOLE E IDONEE PER LE ISOLE ROBOTIZZATE
SUITABLE TO BOXES PRODUCTION AND ROBOT BENDING CELLS

AMADA - PROMECAM STYLE

MATRICI

DIES

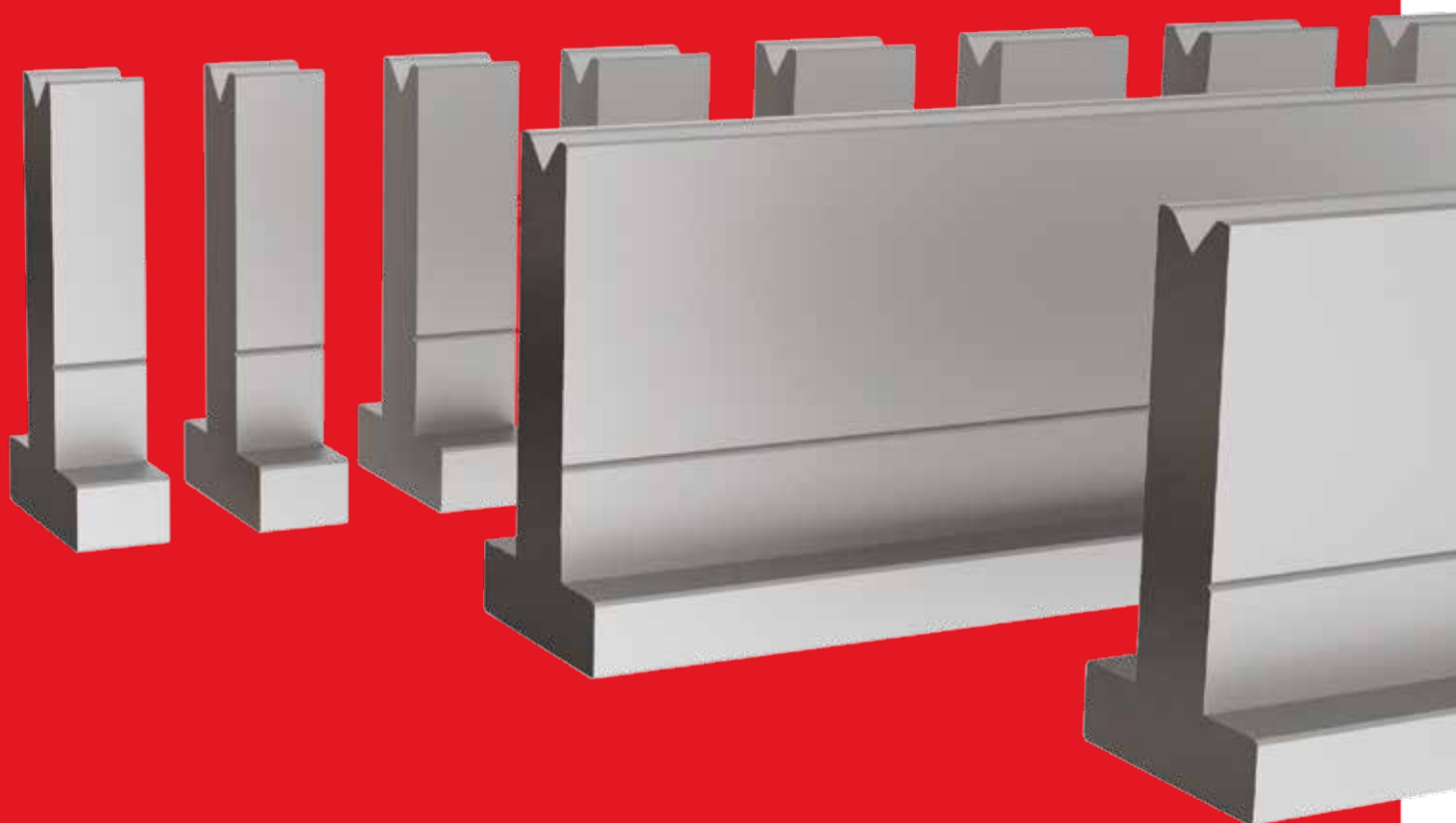

RED LINE

AMADA - PROMECAM STYLE



MATRICI / DIES *AMADA - PROMECAM STYLE* 2V / 4V

LE MATRICI STANDARD SONO DISPONIBILI A MAGAZZINO NELLE LUNGHEZZE DI: 415 / 835 E FRAZIONATI (805 mm)
 THE DIES ARE AVAILABLE IN THE FOLLOWING STANDARD LENGTHS: 415 / 835 AND SECTIONED (805 mm)



TEMPRA AD INDUZIONE 52-55 HRC
 INDUCTION HARDENED 52-55 HRC

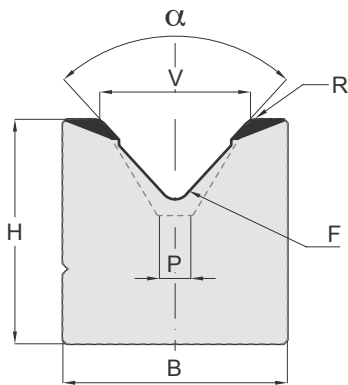

415 mm

835 mm

805 mm

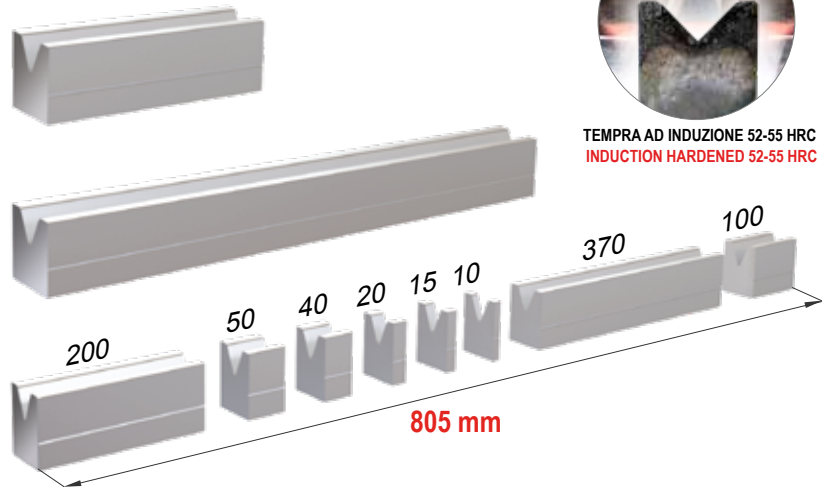

LEGENDA	α = ANGOLO	V = AMPIEZZA CAVA	R = RAGGIO	H = ALTEZZA	F= FONDO MATRICE	P= PIANO	B= BASE
LEGEND	α = ANGLE	V = DIE OPENING	R = RADIUS	H = HEIGHT	F= BOTTOM DIES	P= FLAT	B= WIDTH

CODE	T/Mt	Mt
21.209	100	■

415 mm
 835 mm
 805 mm SECTIONED

CODE	α	T/Mt	Mt
20.350	60°	60	■

415 mm
 835 mm
 805 mm SECTIONED

CODE	α	T/Mt	Mt
21.207	85°	80	■

415 mm
 835 mm
 805 mm SECTIONED

CODE	α	H	T/Mt	Mt
20.820	85°	80.00	100	■

415 mm
 835 mm
 805 mm SECTIONED

CODE	α	H	T/Mt	Mt
20.830	30°	80.00	100	■

415 mm
 835 mm
 805 mm SECTIONED

CODE	α	H	T/Mt	Mt
28.820	60° - 80°	90	80	■

415 mm
 835 mm
 805 mm SECTIONED

CODE	α	V	R	H	T/Mt	Mt
20.494	30°	18	2.00	60.00	100	■

415 mm
835 mm
805 mm SECTIONED

CODE	α	V	R	H	T/Mt	Mt
20.325	30°	25	3.00	60.00	100	■

415 mm
835 mm
805 mm SECTIONED

CODE	α	V	R	H	T/Mt	Mt
20.210	85°	32	4.00	60.00	100	■

415 mm
835 mm
805 mm SECTIONED

CODE	α	V	R	H	T/Mt	Mt
20.211	85°	40	4.00	60.00	100	■

415 mm
835 mm
805 mm SECTIONED

CODE	α	V	R	H	T/Mt	Mt
20.212	85°	50	4.00	60.00	100	■

415 mm
835 mm
805 mm SECTIONED

CODE	α	V	R	H	T/Mt	Mt
20.484	45°	32	4.00	80.00	100	■

415 mm
835 mm
805 mm SECTIONED

CODE	α	V	R	H	T/Mt	Mt
20.440	45°	40	4.00	75.00	100	■

415 mm
835 mm
805 mm SECTIONED

CODE	α	V	R	H	T/Mt	Mt
20.650	60°	50	5.00	75.00	100	■

415 mm
835 mm
805 mm SECTIONED

CODE	α	V	R	H	T/Mt	Mt
20.370	60°	63	5.00	86.00	100	■

415 mm
835 mm
805 mm SECTIONED

MATRICI / DIES *AMADA - PROMECAM STYLE* 45° / 60° / 80° / 85°

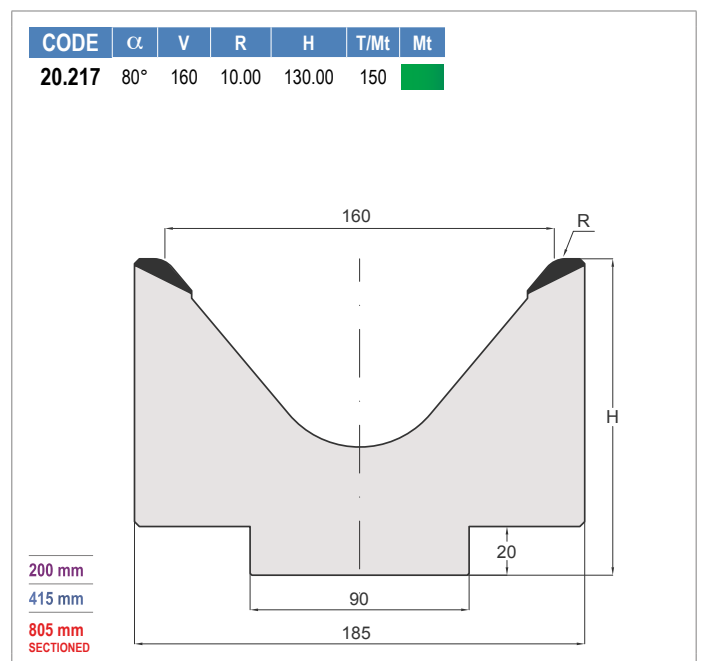
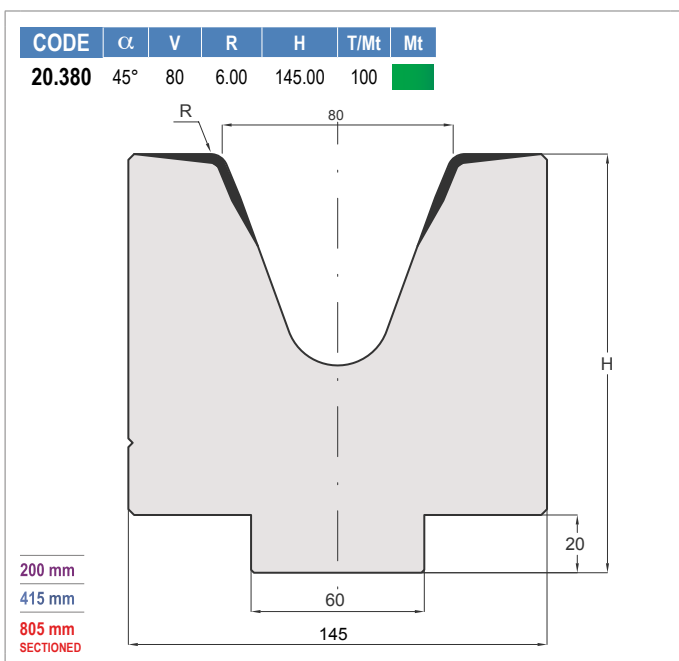
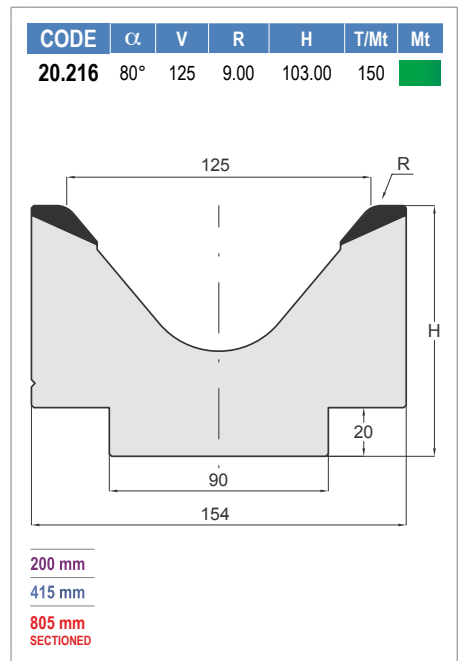
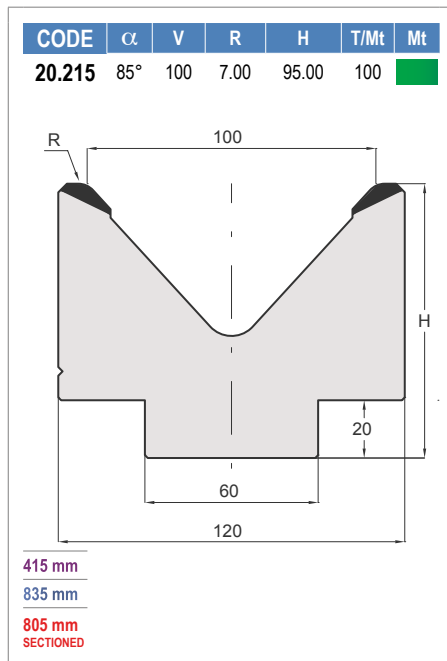
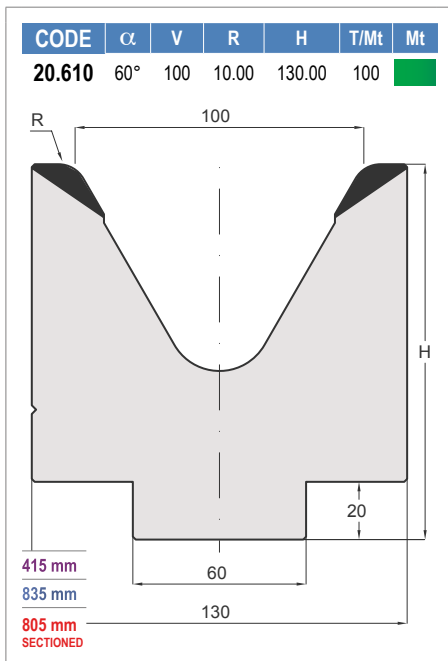
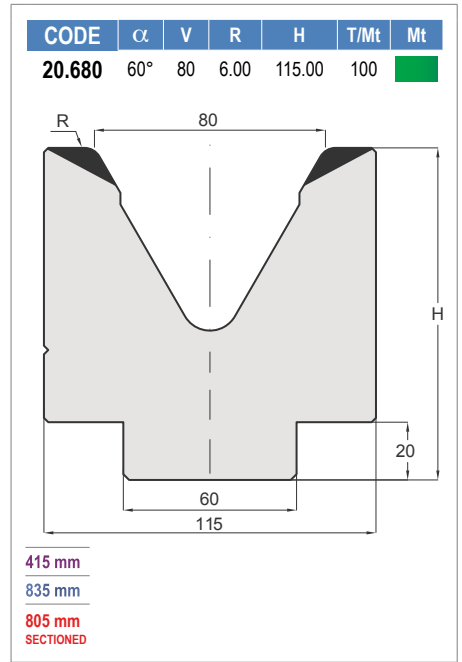
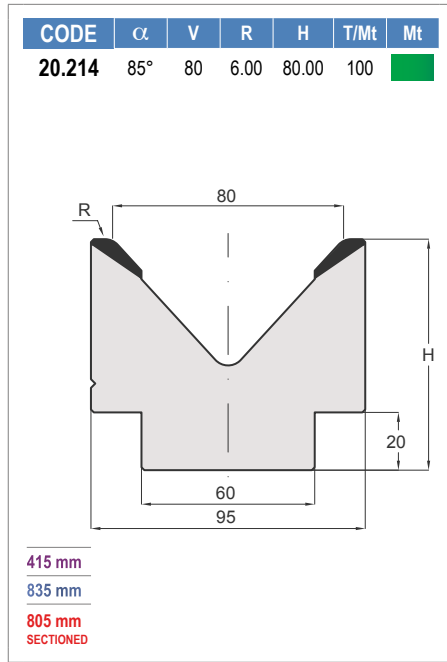
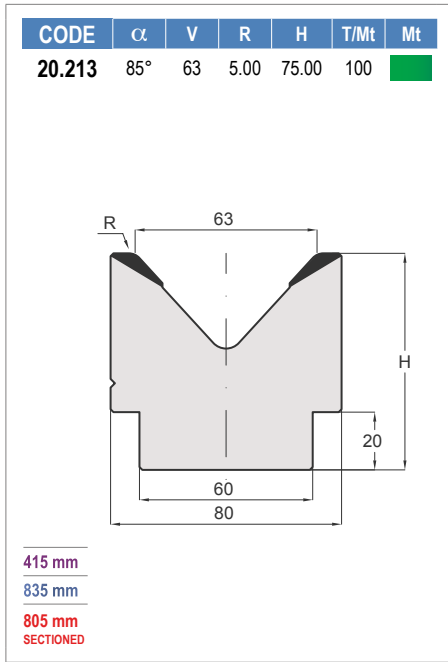

CODE	α	V	R	H	T/Mt	Mt
21.125	80°	125	9.00	103.00	150	■

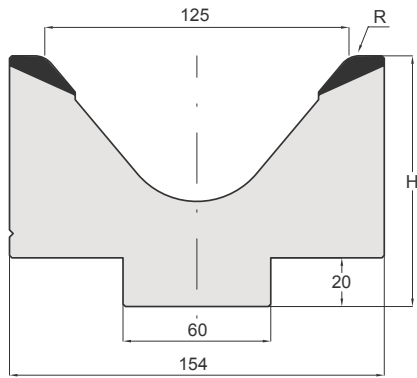

200 mm
415 mm
805 mm
SECTIONED

CODE	α	V	R	H	T/Mt	Mt
21.160	80°	160	10.00	130.00	150	■

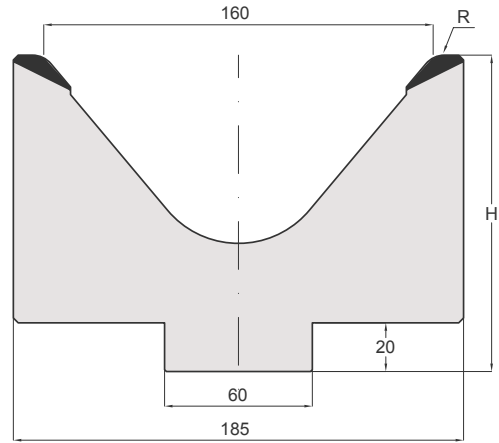

200 mm
415 mm
805 mm
SECTIONED

CODE	α	V	R	H	T/Mt	Mt
21.200	70°	200	15.00	185.00	200	■

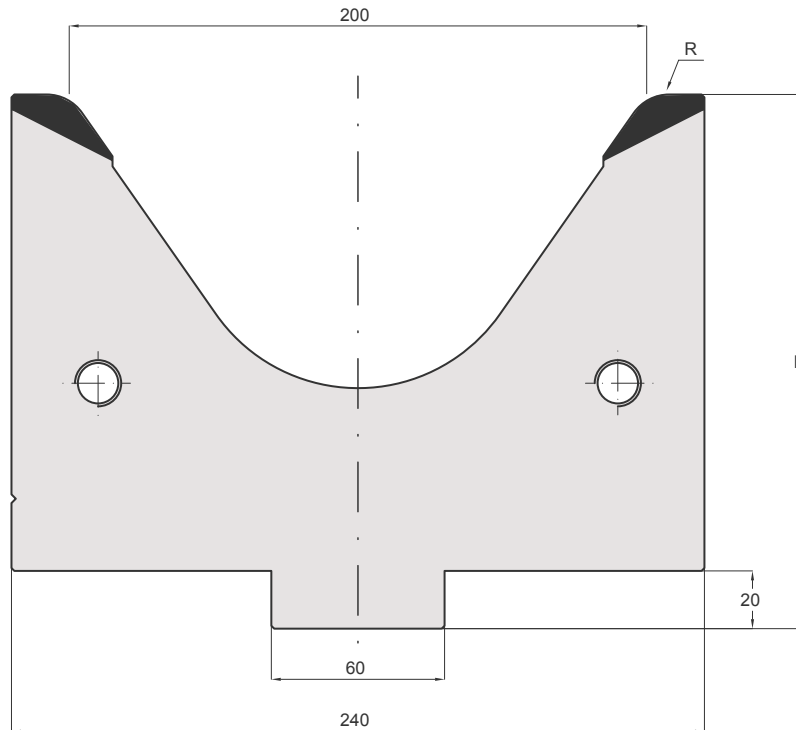

200 mm
415 mm

MATRICI / DIES AMADA - PROMECAM STYLE H=80

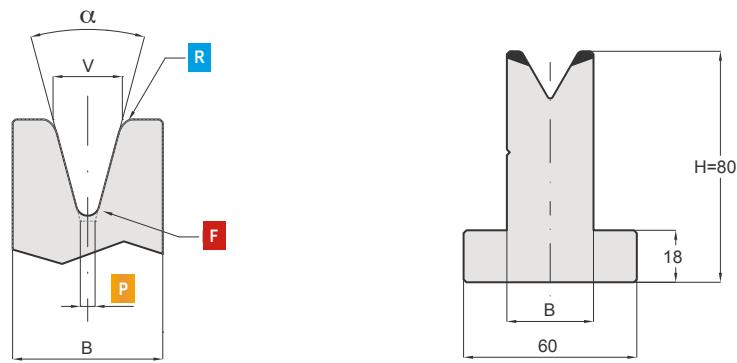

LE MATRICI STANDARD SONO DISPONIBILI A MAGAZZINO NELLE LUNGHEZZE DI: 415 mm - 835 mm E FRAZIONATI (805 mm)
 THE DIES ARE AVAILABLE IN THE FOLLOWING STANDARD LENGTHS: 415 mm - 835 mm AND SECTIONED (805 mm)

LEGENDA	F = FONDO MATRICE	R = RAGGIO	P = PIANO
LEGEND	F = BOTTOM DIE	R = RADIUS	P = FLAT

415 mm | 835 mm | 805 mm SECTIONED

CODE	α	V	R	H	B	F	T/mt	Mt
20.806	88°	6	0.80	80	14	R0.5	100	■
20.808	88°	8	1.00	80	14	R0.5	100	■
20.810	88°	10	1.20	80	18	R0.5	100	■
20.371	88°	12	1.50	80	18	R0.5	100	■
20.327	88°	16	2.00	80	24	R0.5	100	■
20.310	88°	20	2.00	80	30	R1.0	100	■
20.309	88°	25	3.00	80	35	R1.0	100	■
20.506	85°	6	1.50	80	14	R0.5	100	■
20.508	85°	8	2.00	80	14	R0.5	100	■
20.510	85°	10	2.50	80	18	R0.5	100	■
20.512	85°	12	3.00	80	18	R0.5	100	■
20.516	85°	16	3.50	80	24	R0.5	100	■
20.520	85°	20	4.00	80	30	R1.0	100	■
20.525	85°	25	5.00	80	35	R1.0	100	■
20.297	60°	6	0.40	80	14	R0.5	60	■
20.298	60°	8	0.50	80	14	R0.5	60	■
20.299	60°	10	0.60	80	18	R0.5	60	■
20.300	60°	12	0.80	80	18	R0.5	60	■
20.301	60°	16	1.60	80	24	R0.7	60	■
20.308	60°	20	2.00	80	30	R1.0	60	■
20.311	60°	25	3.00	80	35	R1.0	60	■
20.328	45°	6	0.60	80	14	R0.8	50	■
20.329	45°	8	0.80	80	18	R0.8	50	■
20.330	45°	10	1.00	80	18	R0.8	50	■
20.331	45°	12	1.50	80	24	R0.8	50	■
20.332	45°	16	2.00	80	24	R1.5	50	■
20.333	45°	20	2.50	80	30	R1.5	50	■
20.334	45°	25	3.00	80	35	R1.5	50	■
20.406	35°	6	1.50	80	14	R1.0	40	■
20.408	35°	8	2.00	80	18	P2.0	40	■
20.410	35°	10	2.50	80	24	P2.0	55	■
20.412	35°	12	3.00	80	24	P2.0	45	■
20.416	35°	16	3.50	80	30	P2.0	50	■
20.420	35°	20	4.00	80	35	P5.0	60	■
20.425	35°	25	5.00	80	40	P5.0	60	■
20.317	30°	6	0.60	80	14	R1.0	35	■
20.318	30°	8	0.80	80	18	P2.0	35	■
20.319	30°	10	1.00	80	24	P2.0	50	■
20.320	30°	12	1.50	80	24	P2.0	40	■
20.321	30°	16	2.00	80	30	P5.0	45	■
20.322	30°	20	2.50	80	35	P5.0	50	■
20.323	30°	25	3.00	80	40	P5.0	50	■

MATRICI / DIES AMADA - PROMECAM STYLE H=120

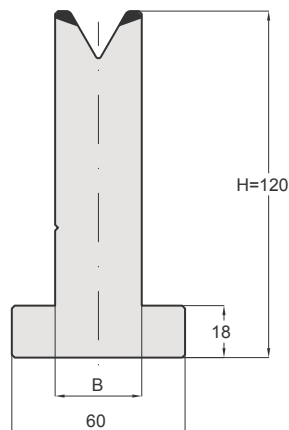
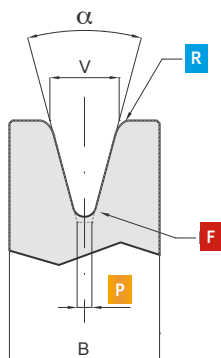

LE MATRICI STANDARD SONO DISPONIBILI A MAGAZZINO NELLE LUNGHEZZE DI: 415 mm - 835 mm E FRAZIONATI (805 mm)

THE DIES ARE AVAILABLE IN THE FOLLOWING STANDARD LENGTHS: 415 mm - 835 mm AND SECTIONED (805 mm)

LEGENDA	F = FONDO MATRICE	R = RAGGIO	P = PIANO
LEGEND	F = BOTTOM DIE	R = RADIUS	P = FLAT

415 mm | 835 mm | 805 mm SECTIONED

CODE	α	V	R	H	B	F	T/mt	Mt
21.806	88°	6	0.80	120	14	R0.5	100	■
21.808	88°	8	1.00	120	14	R0.5	100	■
21.810	88°	10	1.20	120	18	R0.5	100	■
20.382	88°	12	1.50	120	18	R0.5	100	■
20.383	88°	16	2.00	120	24	R0.5	100	■
20.384	88°	20	2.00	120	30	R1.0	100	■
20.385	88°	25	3.00	120	35	R1.0	100	■
21.506	85°	6	1.50	120	14	R0.5	100	■
21.508	85°	8	2.00	120	14	R0.5	100	■
21.510	85°	10	2.50	120	18	R0.5	100	■
21.512	85°	12	3.00	120	18	R0.5	100	■
21.516	85°	16	3.50	120	24	R0.5	100	■
21.520	85°	20	4.00	120	30	R1.0	100	■
21.525	85°	25	5.00	120	35	R1.0	100	■
20.386	60°	6	0.40	120	14	R0.5	60	■
20.387	60°	8	0.50	120	14	R0.5	60	■
20.388	60°	10	0.60	120	18	R0.5	60	■
20.389	60°	12	0.80	120	18	R0.5	60	■
20.390	60°	16	1.60	120	24	R0.7	60	■
20.391	60°	20	2.00	120	30	R1.0	60	■
20.392	60°	25	3.00	120	35	R1.0	60	■
20.393	45°	6	0.60	120	14	R0.8	50	■
20.394	45°	8	0.80	120	18	R0.8	50	■
20.395	45°	10	1.00	120	18	R0.8	50	■
20.396	45°	12	1.50	120	24	R0.8	50	■
20.397	45°	16	2.00	120	24	R1.5	50	■
20.398	45°	20	2.50	120	30	R1.5	50	■
20.399	45°	25	3.00	120	35	R1.5	50	■
21.406	35°	6	1.50	120	14	R1.0	40	■
21.408	35°	8	2.00	120	18	P2.0	40	■
21.410	35°	10	2.50	120	24	P2.0	55	■
21.412	35°	12	3.00	120	24	P2.0	45	■
21.416	35°	16	3.50	120	30	P2.0	50	■
21.420	35°	20	4.00	120	35	P5.0	60	■
21.425	35°	25	5.00	120	40	P5.0	60	■
20.351	30°	6	0.60	120	14	R1.0	35	■
20.352	30°	8	0.80	120	18	P2.0	35	■
20.353	30°	10	1.00	120	24	P2.0	50	■
20.354	30°	12	1.50	120	24	P2.0	40	■
20.401	30°	16	2.00	120	30	P5.0	45	■
20.402	30°	20	2.50	120	35	P5.0	50	■
20.403	30°	25	3.00	120	40	P5.0	50	■

MATRICI / DIES *AMADA - PROMECAM STYLE* 2V H=26 / H=46

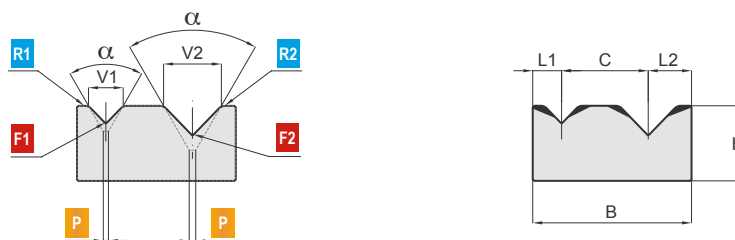

LE MATRICI STANDARD SONO DISPONIBILI A MAGAZZINO NELLE LUNGHEZZE DI: 415 mm - 835 mm (NON FRAZIONABILE)
 THE DIES ARE AVAILABLE IN THE FOLLOWING STANDARD LENGTHS: 415 mm - 835 mm (NOT SECTIONABLE)

LEGENDA	F1 / F2 = FONDO MATRICE	R1 / R2 = RAGGIO	P = PIANO
LEGEND	F1 / F2 = BOTTOM DIE	R1 / R2 = RADIUS	P = FLAT

415 mm | 835 mm

CODE	α	V1	V2	R1	R2	F1	F2	L1	L2	H	B	C	T/Mt	Mt
21.202	88°	6	10	0.80	1.20	R0.5	R0.5	6	10	26	55	39	100	■
20.338	88°	8	12	1.00	1.50	R0.5	R0.5	8	10	26	55	37	100	■
20.204	88°	12	20	2.75	3.00	R0.5	R0.5	10	15	26	55	30	100	■
20.296	88°	14	18	2.75	3.00	R0.5	R0.5	11	13	26	55	31	100	■
20.205	88°	16	25	2.75	3.00	R0.5	R0.5	12	16.5	26	55	26.5	100	■
20.235	60°	6	10	0.40	0.60	R0.5	R0.5	6	10	26	55	39	60	■
20.229	60°	8	12	0.50	0.80	R0.5	R0.5	8	10	26	55	37	60	■
20.230	60°	12	20	0.80	1.50	R0.5	R0.5	10	15	26	55	30	60	■
20.267	60°	16	20	1.60	2.00	R0.7	R0.7	12	15	26	55	28	60	■
20.418	30°	8	12	0.80	1.50	P2.0	P2.0	9.5	14.5	46	50	26	40	■

SUPPORTI MATRICE / DIE HOLDERS *AMADA - PROMECAM STYLE*

CODE	H1	H2	T/Mt	Mt
20.200	34.00	20.00	100	■

412 mm
830 mm

CODE	H1	H2	T/Mt	Mt
20.201	55.00	35.00	100	■

412 mm
830 mm

CODE	H1	H2	T/Mt	Mt
20.306	75.00	55.00	100	■

412 mm
830 mm

CODE	H1	H2	T/Mt	Mt
20.316	39.00	20.00	100	■

412 mm
830 mm

SCHEMA DI MONTAGGIO
ASSEMBLY SCHEME

NON FRAZIONABILE
NOT SECTIONABLE

MATRICI / DIES *AMADA - PROMECAM STYLE* 2V H=46

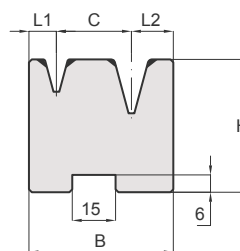
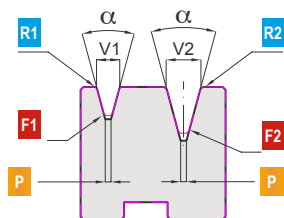

LE MATRICI STANDARD SONO DISPONIBILI A MAGAZZINO NELLE LUNGHEZZE DI: 415 mm - 835 mm E FRAZIONATI (805 mm)
 THE DIES ARE AVAILABLE IN THE FOLLOWING STANDARD LENGTHS: 415 mm - 835 mm AND SECTIONED (805 mm)

LEGENDA	F1 / F2 = FONDO MATRICE	R1 / R2 = RAGGIO	P = PIANO
LEGEND	F1 / F2 = BOTTOM DIE	R1 / R2 = RADIUS	P = FLAT

415 mm | 835 mm | 805 mm SECTIONED

CODE	α	V1	V2	R1	R2	F1	F2	L1	L2	H	B	C	T/Mt	Mt
21.275	88°	4	7	0.60	1.00	R0.5	R0.5	3.50	5.00	46	34.5	26	80	■
21.276	88°	6	10	0.80	1.20	R0.5	R0.5	4.50	6.50	46	37	26	80	■
20.339	88°	8	12	1.00	1.50	R0.5	R0.5	5.50	7.50	46	39	26	80	■
20.279	88°	12	20	0.80	1.75	R0.5	R0.5	7.50	12.00	46	45.5	26	80	■
20.278	88°	14	18	1.25	1.50	R0.5	R0.5	8.50	10.50	46	45	26	80	■
20.280	88°	16	25	1.50	1.75	R0.5	R0.5	9.50	14.50	46	50	26	80	■
20.344	85°	4	7	0.60	1.00	R0.5	R0.5	3.50	5.00	46	34.5	26	80	■
20.345	85°	6	10	1.00	1.50	R0.5	R0.5	4.50	6.50	46	37	26	80	■
20.346	85°	8	12	1.20	1.75	R0.5	R0.5	5.50	7.50	46	39	26	80	■
20.347	85°	12	20	1.75	2.50	R0.5	R0.5	7.50	12.00	46	45.5	26	80	■
20.349	85°	14	18	1.50	2.00	R0.5	R0.5	8.50	10.50	46	45	26	80	■
20.348	85°	16	25	2.00	3.00	R0.5	R1.0	9.50	14.50	46	50	26	80	■
20.438	30°	6	10	0.60	1.00	R1.0	P2.0	7.00	12.00	46	45	26	40	■
20.478	30°	8	12	0.80	1.50	P2.0	P2.0	9.50	14.50	46	50	26	40	■

SUPPORTI MATRICE / DIE HOLDERS *AMADA - PROMECAM STYLE*

CODE	H1	T/Mt	Mt
20.287	10.00	100	■

415 mm
835 mm

CODE	H1	T/Mt	Mt
20.400	20.00	100	■

415 mm
835 mm

CODE	Mt
20.336	■

MATRICE AUTOCENTRANTE
SELF CENTERING DIE

SUPPORTO PER MATRICE AUTOCENTRANTE 2V
RAIL FOR SELF CENTERING 2V DIES

SUPPORTO PER MATRICE
DIE HOLDER

34 mm
39 mm
55 mm
75 mm

SCHEMA DI MONTAGGIO
ASSEMBLY SCHEME

SUPPORTI MATRICE / DIE HOLDERS *AMADA - PROMECAM STYLE*

BLOCCAGGIO STANDARD - 8 VITI
 NORMAL LOCKING - 8 SCREWS

CODE	Mt
22.010	

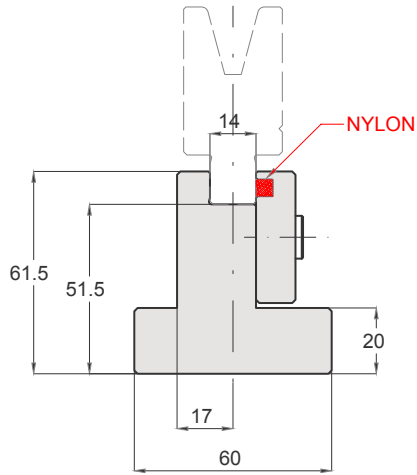

415 mm
 835 mm



BLOCCAGGIO VELOCE - 2 VITI
 FAST LOCKING, 2 SCREWS

CODE	Mt
22.020	



BLOCCAGGIO RAPIDO
FAST LOCKING

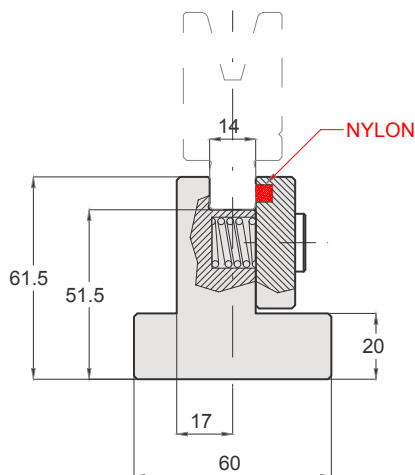

415 mm
 835 mm



INSERTI MATRICE / DIE INSERTS *AMADA - PROMECAM STYLE*

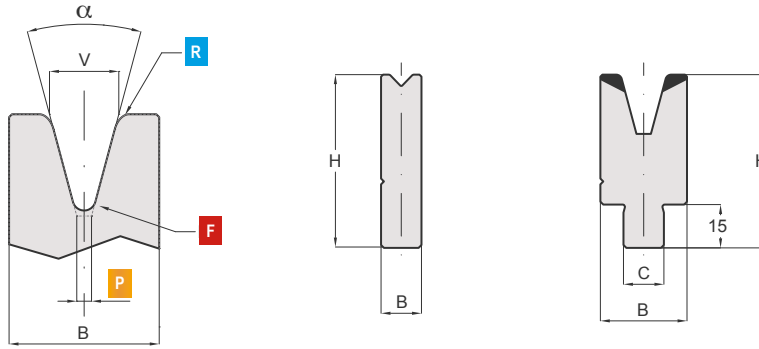

LE MATRICI STANDARD SONO DISPONIBILI A MAGAZZINO NELLE LUNGHEZZE DI: 415 mm - 835 mm E FRAZIONATI (805 mm)
 THE DIES ARE AVAILABLE IN THE FOLLOWING STANDARD LENGTHS: 415 mm - 835 mm AND SECTIONED (805 mm)

LEGENDA	F = FONDO MATRICE	R = RAGGIO	P = PIANO
LEGEND	F = BOTTOM DIE	R = RADIUS	P = FLAT

415 mm | 835 mm | 805 mm SECTIONED

CODE	α	V	R	H	B	C	F	T/mt	Mt
22.804	88°	4	0.60	60	14	14	R0.5	100	■
22.806	88°	6	0.80	60	14	14	R0.5	100	■
22.808	88°	8	1.00	60	14	14	R0.5	100	■
22.810	88°	10	1.20	60	18	14	R0.5	100	■
22.812	88°	12	1.50	60	18	14	R0.5	100	■
22.816	88°	16	2.00	60	24	14	R0.5	100	■
22.820	88°	20	2.00	60	30	14	R1.0	100	■
22.825	88°	25	3.00	60	35	14	R1.0	100	■
22.832	84°	32	4.00	60	38	14	R2.0	100	■
22.840	84°	40	4.00	60	46	14	R2.0	100	■
22.606	60°	6	0.60	60	12	14	R0.6	38	■
22.608	60°	8	0.80	60	13.5	14	R0.8	45	■
22.610	60°	10	1.00	60	16	14	R1.0	55	■
22.612	60°	12	1.20	60	17	14	R1.0	55	■
22.616	60°	16	1.60	60	22	14	R1.0	65	■
22.620	60°	20	2.00	60	28	14	R1.0	85	■
22.625	60°	25	2.50	60	31	14	R1.0	85	■
22.432	45°	32	5.00	80	50	14	R5.0	100	■
22.440	45°	40	5.00	80	60	14	R5.0	100	■
22.306	30°	6	0.60	60	14	14	R1.0	35	■
22.308	30°	8	0.80	60	18	14	P2.0	35	■
22.310	30°	10	1.00	60	24	14	P2.0	50	■
22.312	30°	12	1.50	60	24	14	P2.0	40	■
22.316	30°	16	2.00	60	30	14	P5.0	45	■
22.320	30°	20	2.50	60	35	14	P5.0	50	■
22.325	30°	25	3.00	65	45	14	P8.0	50	■



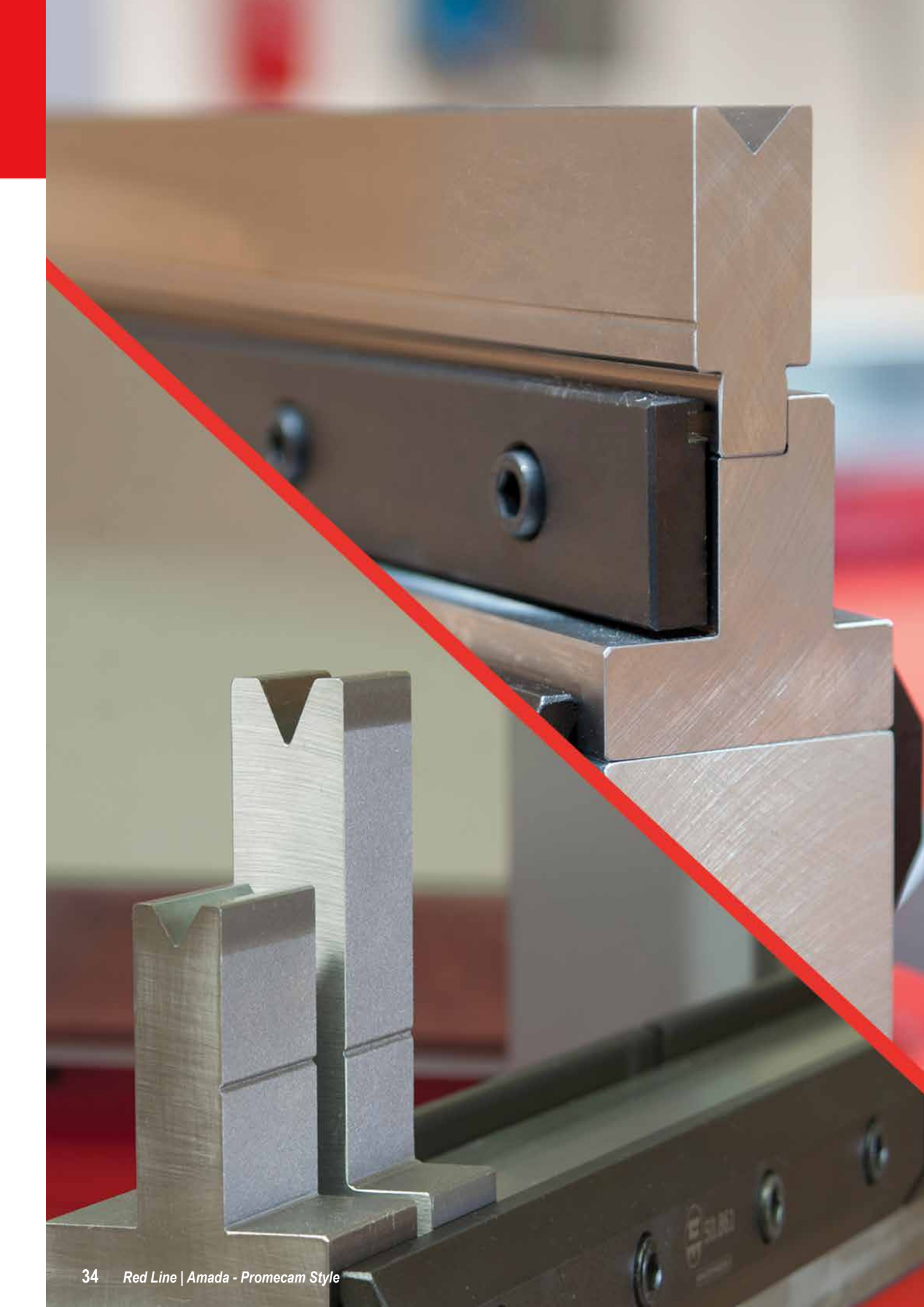

AMADA - PROMECAM STYLE

PIEGASCHIACCIA

HEMMING TOOLS



RED LINE

AMADA - PROMECAM STYLE



MATRICI PIEGASCHIACCIA / HEMMING DIES **AMADA STYLE**

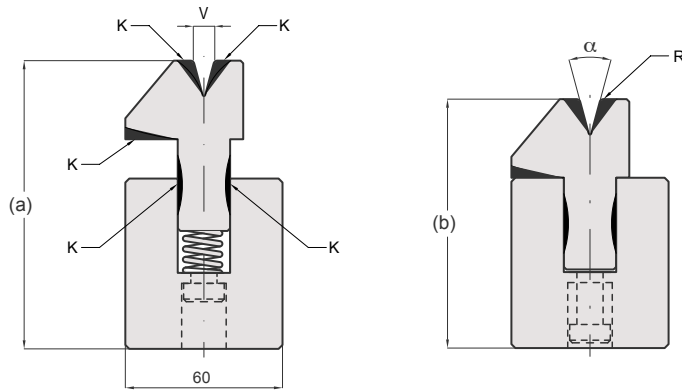

LEGENDA	(a) = APERTO	(b) = CHIUSO	(α) = ANGOLO	V = AMPIEZZA CAVA	R = RAGGIO	K = PARTI USURABILI
LEGEND	(a) = OPEN	(b) = CLOSED	(α) = ANGLE	V = DIE OPENING	R = RADIUS	K = WEAR PARTS

415 mm | 835 mm

CODE	α	V	R	T/Mt	Mt
20.264	35°	6	1.00	60	

Max sp 1mm
Max tk 1mm
415 mm
835 mm

CODE	α	V	R	T/Mt	Mt
20.303	30°	8	1.50	80	

Max sp 1,5mm
Max tk 1,5mm
415 mm
835 mm

CODE	α	V	R	T/Mt	Mt
20.450	30°	8	1.50	60	

Max sp 1,5mm
Max tk 1,5mm
415 mm
835 mm

CODE	α	V	R	T/Mt	Mt
20.231	26°	10	1.50	100	

Max sp 2mm
Max tk 2mm
415 mm
835 mm

CODE	α	V	R	T/Mt	Mt
20.305	26°	12	3.00	100	

Max sp 3mm
Max tk 3mm
415 mm
835 mm

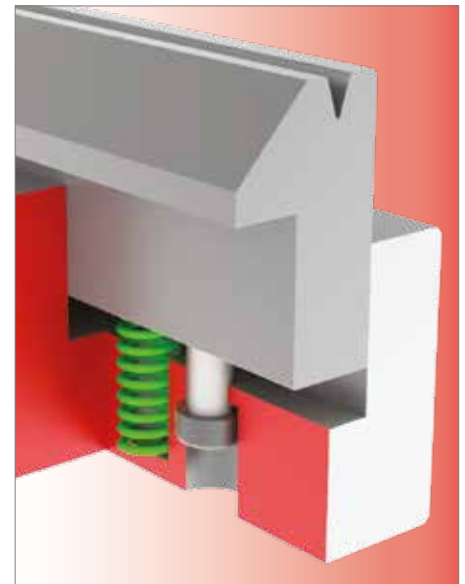

CODE
70.100

SPARE PARTS

CODE
70.102

SPARE PARTS

MATRICI PIEGASCHIACCIA PNEUMATICHE / PNEUMATIC HEMMING DIES **AMADA STYLE**

I PIEGASCHIACCIA PNEUMATICI SONO EQUIPAGGIATI CON CILINDRI AD ARIA, RICAVANDONE I SEGUENTI VANTAGGI:

- A) RECUPERO DI 15 MM DI LUCE E DI CORSA CON CONSEGUENTE RIDUZIONE DEI TEMPI DI LAVORAZIONE.
- B) MAGGIOR PRECISIONE DI PIEGA
- C) MINOR USURA DEGLI UTENSILI
- D) COLLEGAMENTO AL CNC



PNEUMATIC FLATTENING DIES ARE EQUIPPED WITH AIR CYLINDERS, GETTING THE FOLLOWING BENEFITS:

- A) SAVING 15 MM LIGHT AND STROKE WITH REDUCTION OF WORKING TIME.
- B) MORE PRECISE BENDING
- C) LESS WEAR
- D) CONNETTABLE TO EXISTING FREE CONTROL-OUTPUT I/O

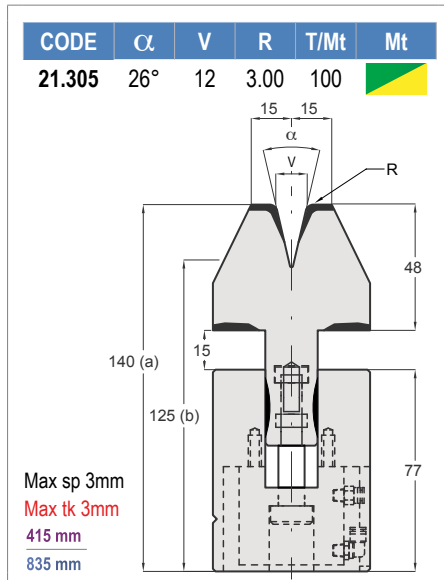
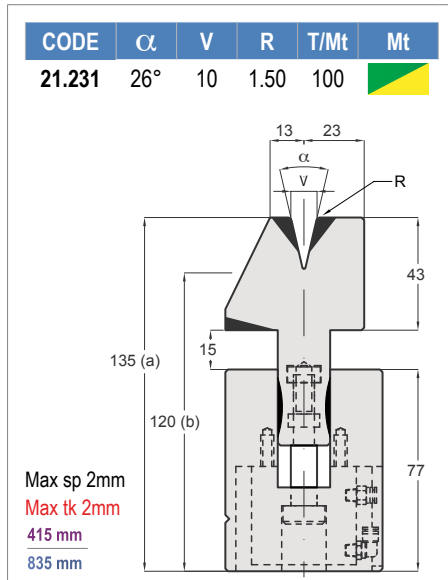
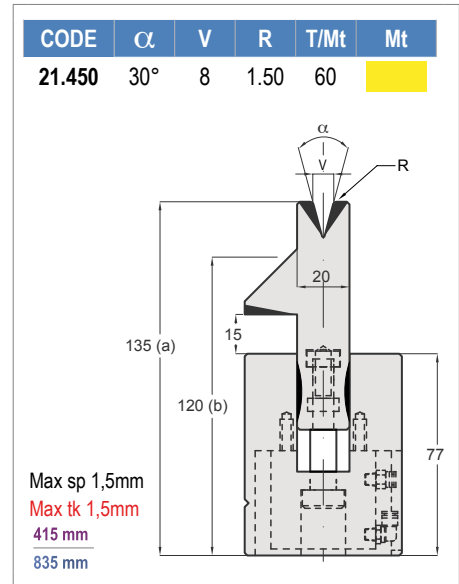
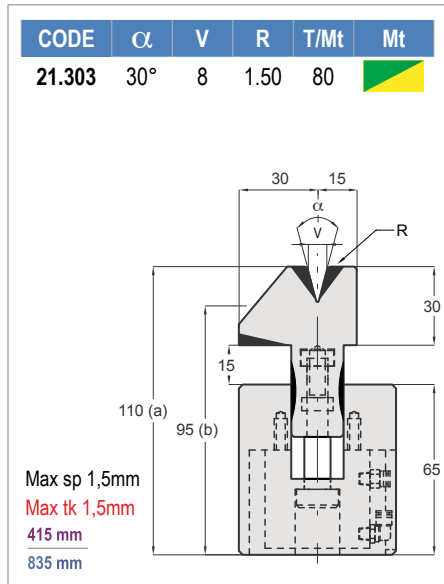
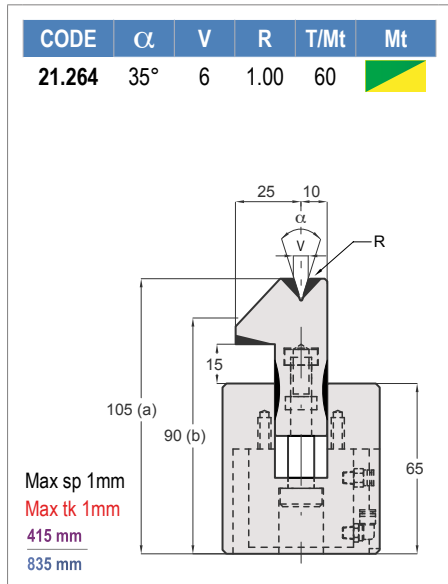

PIEGASCHIACCIA / HEMMING TOOLS *AMADA - PROMECAM STYLE*

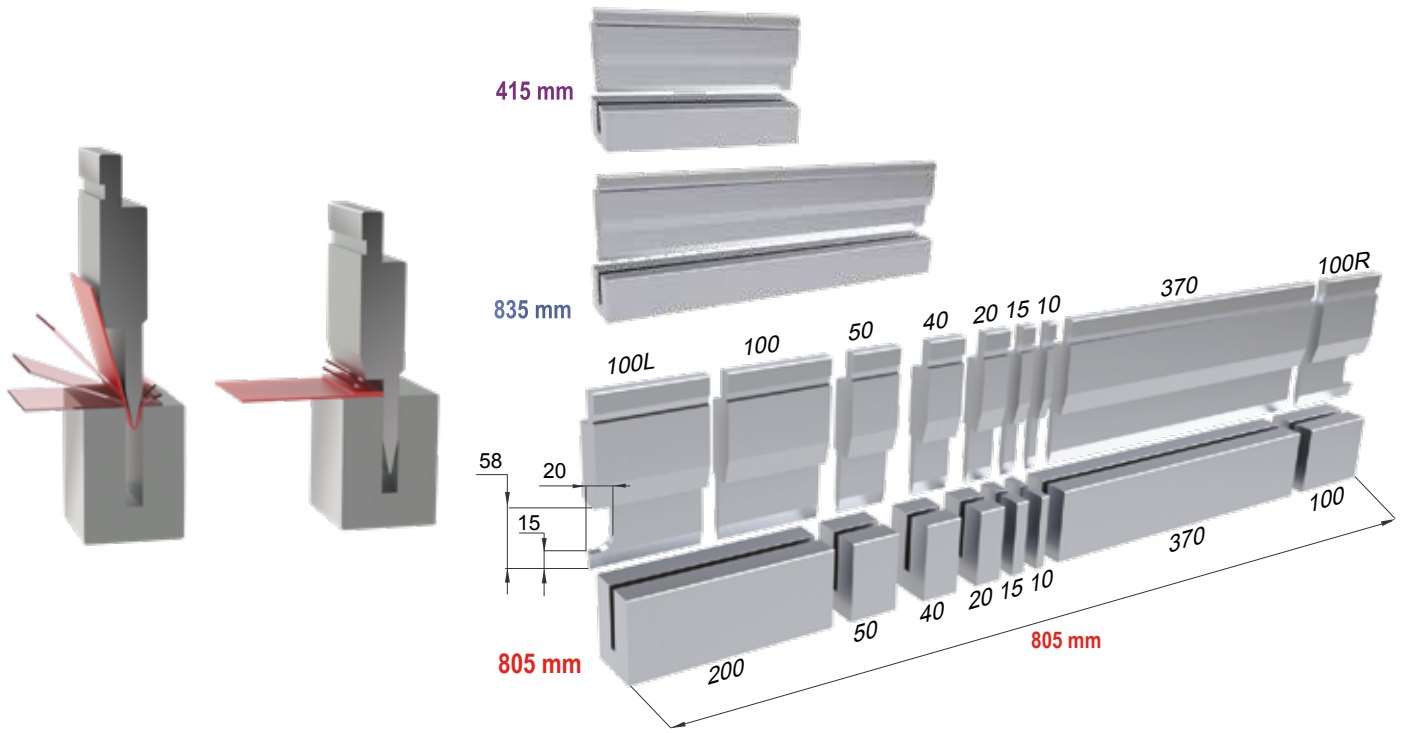

IL CARICO MASSIMO DELLE SCARPETTE CORRISPONDE AL 50% DEL CARICO MASSIMO INDICATO SUL PUNZONE.
 THE MAX LOAD OF THE HORN EXTENSIONS IS 50% OF THE MAX LOAD OF THE PUNCH.

MATERIAL ACC.R ~ 40 Kg/MM ²					MATERIAL ACC.R ~ 70 Kg/MM ²				
MATERIAL ACC.R ~ 40 Kg/MM ²					MATERIAL ACC.R ~ 70 Kg/MM ²				
S (mm)	(t/m)	T (mm)	(t/m)	2S(mm)	S (mm)	(t/m)	T (mm)	(t/m)	2S(mm)
0,6	9	3	23	1,2	0,6	15	3	35	1,2
0,8	12	3	32	1,6	0,8	20	3	50	1,6
1,0	15	3,5	40	2,0	1,0	25	3,5	60	2,0
1,25	17	3,5	50	2,5	1,25	26	3,5	80	2,5
1,5	22	4,6	63	3,0	1,5	38	4,6	95	3,0
2,0	30	5,5	80	4,0	2,0	50	5,5	130	4,0
2,5	55	6,5	90	5,0					
3,0	70	8,0	100	6,0					



CODE	α	R	H	T/Mt	Mt
11.550	24°	0.60	128.00	80	

415 mm
835 mm
805 mm SECTIONED

CODE	α	R	H	T/Mt	Mt
11.554	24°	0.60	128.00	80	

415 mm
835 mm
805 mm SECTIONED

CODE	α	R	H	T/Mt	Mt
11.560	24°	0.60	128.00	80	

415 mm
835 mm
805 mm SECTIONED

CODE	R	H	T/Mt	Mt
20.550	1.00	80.00	50	

SUPERFICIE ZIGRINATA
KNURLED SURFACE

SUPERFICIE RETTIFICATA
GRINDED SURFACE

415 mm
835 mm
805 mm SECTIONED

Max sp 1mm
Max tk 1mm

CODE	R	H	T/Mt	Mt
20.554	1.00	80.00	50	

SUPERFICIE ZIGRINATA
KNURLED SURFACE

SUPERFICIE RETTIFICATA
GRINDED SURFACE

415 mm
835 mm
805 mm SECTIONED

Max sp 1,5mm
Max tk 1,5mm

CODE	R	H	T/Mt	Mt
20.560	1.00	80.00	50	

SUPERFICIE ZIGRINATA
KNURLED SURFACE

SUPERFICIE RETTIFICATA
GRINDED SURFACE

415 mm
835 mm
805 mm SECTIONED

Max sp 2mm
Max tk 2mm



TRUMPF STYLE

PUNZONI

PUNCHES



BLUE LINE

TRUMPF STYLE



PUNZONI / PUNCHES TRUMPF STYLE

SPINTA IN TESTA
FORCE ON HEAD

SPINTA SULLE SPALLE
FORCE ON SHOULDERS

100 mm 200 mm 300 mm 500 mm

25 25 30 35 40 45 50 100 100 R

41/47 100 L 30° 31 12 30°

TEMPRA AD INDUZIONE 52-55 HRC
INDUCTION HARDENED 52-55 HRC

IL CARICO MASSIMO DELLE SCARPETTE CORRISPONDE AL 50% DEL CARICO MASSIMO INDICATO SUL PUNZONE.
THE MAX LOAD OF THE HORN EXTENSIONS IS 50% OF THE MAX LOAD OF THE PUNCH.

LEGENDA	α = ANGOLO	R = RAGGIO	H = ALTEZZA
LEGEND	α = ANGLE	R = RADIUS	H = HEIGHT

I PUNZONI STANDARD SONO DISPONIBILI A MAGAZZINO NELLE LUNGHEZZE DI: 100 / 200 / 300 mm - 500 mm E FRAZIONATI (550 mm)
THE PUNCHES ARE AVAILABLE IN THE FOLLOWING STANDARD LENGTHS: 100 / 200 / 300 mm - 500 mm AND SECTIONED (550 mm)

MONTAGGIO E SMONTAGGIO LATERALE DEGLI UTENSILI
SIDE INSTALLATION AND DISINSTALLATION OF TOOLS

SPINTA IN TESTA
FORCE ON HEAD

SPINTA SULLE SPALLE
FORCE ON SHOULDERS

CODE
70.130

$\varnothing 5$ 26

SPARE PARTS

MONTAGGIO E SMONTAGGIO FRONTALE DEGLI UTENSILI
FRONT INSTALLATION AND DISINSTALLATION OF TOOLS

SPINTA IN TESTA
FORCE ON HEAD

SPINTA SULLE SPALLE
FORCE ON SHOULDERS

SOLO PER STAMPI FINO ≤ 12,5 KG
ONLY FOR TOOLS ≤ 12,5 KG

70.714		15.010	15.310	15.610
70.715		15.320	15.620	
70.716		15.330 15.902	15.335 15.904	15.630 15.905 15.635 15.755
70.717		15.450 15.750	15.710 15.760	15.720 15.730
70.718		15.370	15.480	15.670 15.680
70.719		15.380	15.700	15.800

PUNZONI / PUNCHES TRUMPF STYLE 60° / 80° / 86°

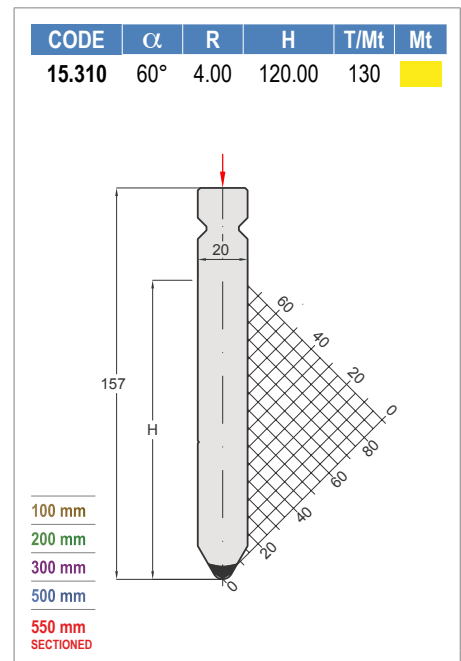
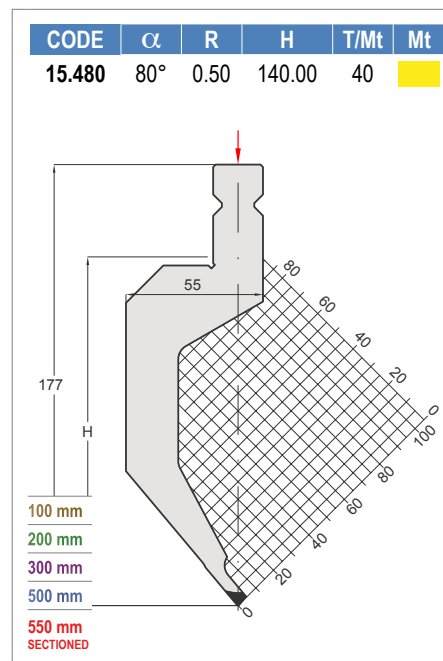
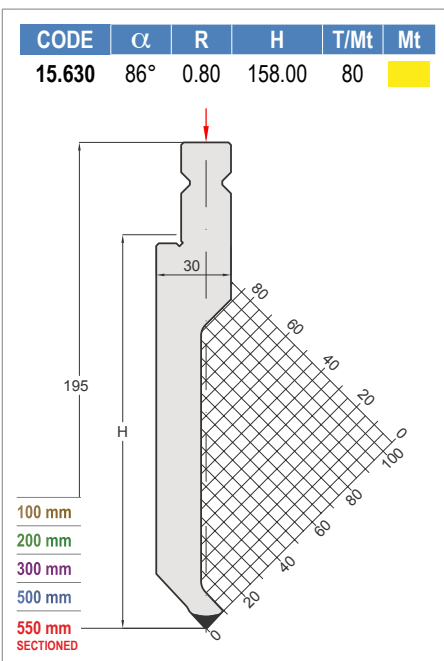
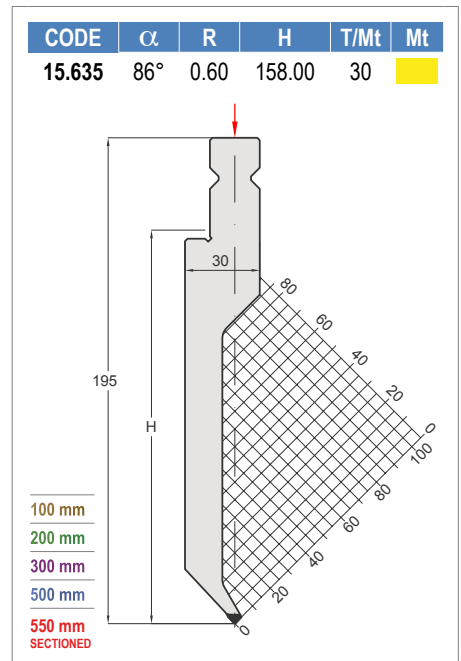
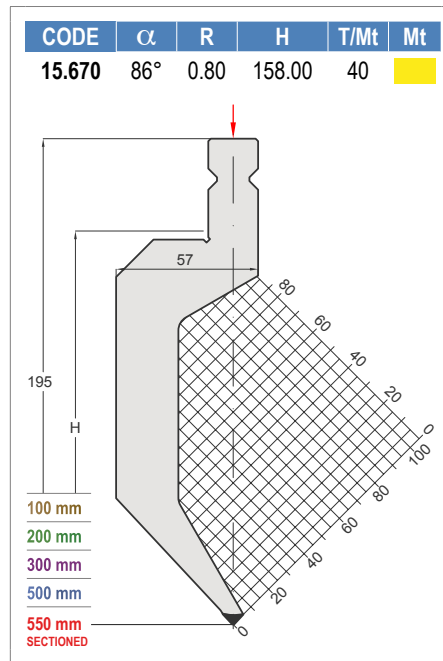
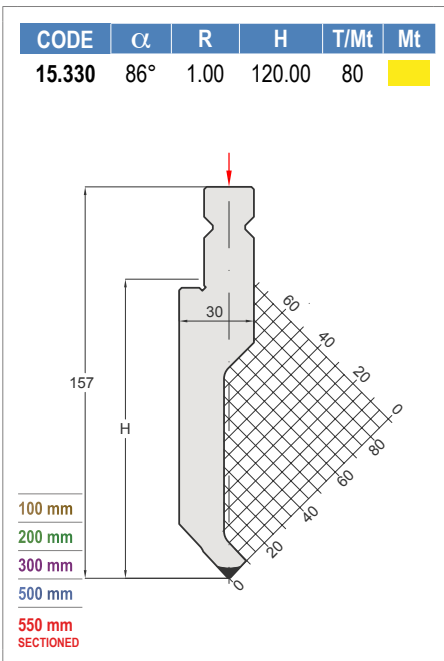
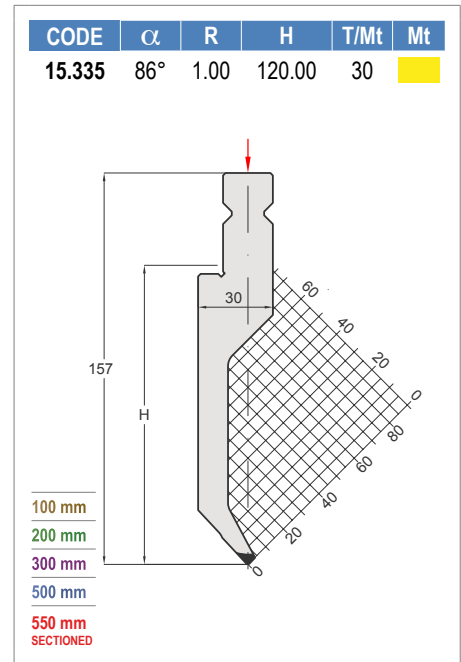
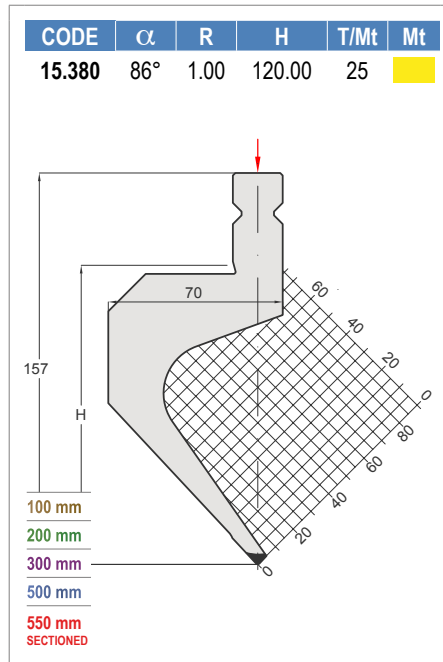
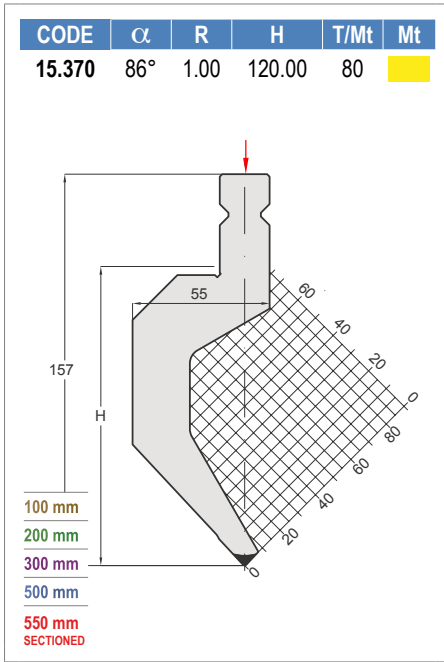

PUNZONI / PUNCHES TRUMPF STYLE 84° / 86°

CODE	α	R	H	T/Mt	Mt
15.700	86°	1.00	220.00	80	■

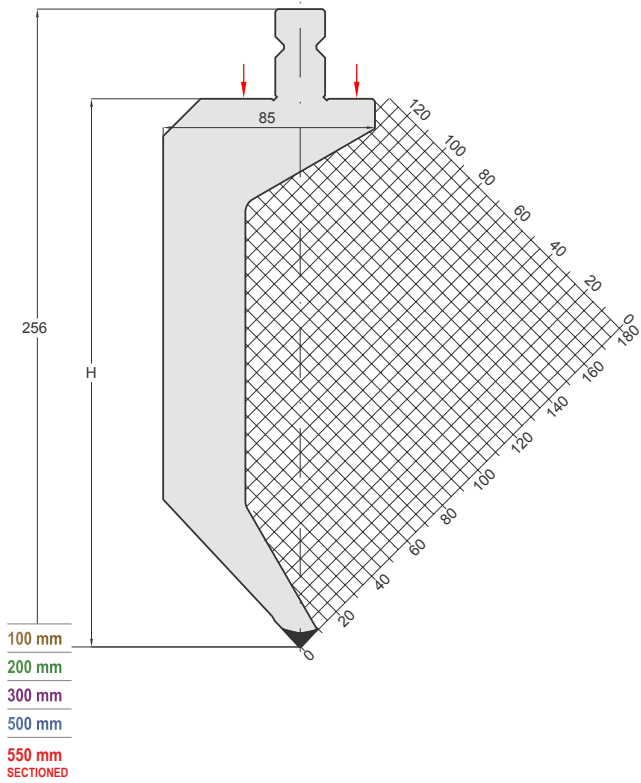

CODE	α	R	H	T/Mt	Mt
15.710	86°	1.00	220.00	80	■

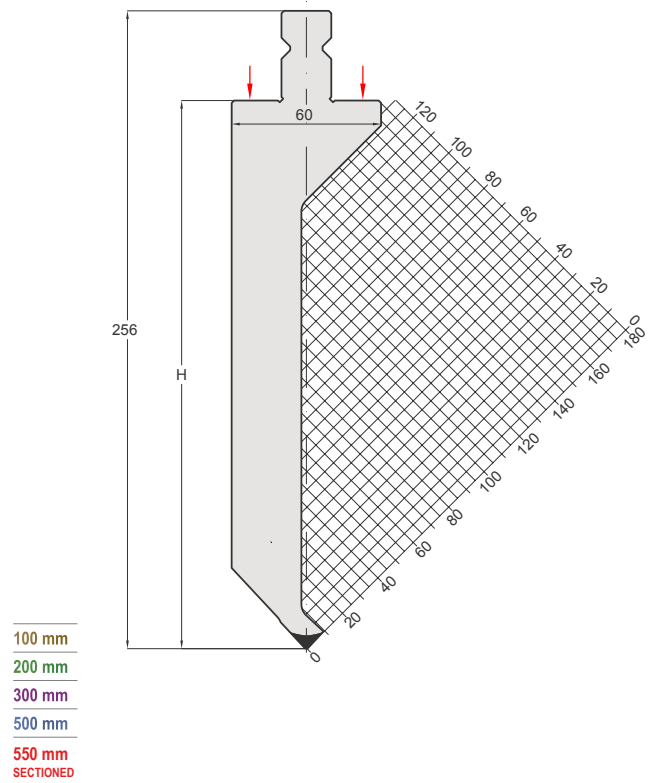

CODE	α	R	H	T/Mt	Mt
15.790	84°	1.00	220.00	60	■

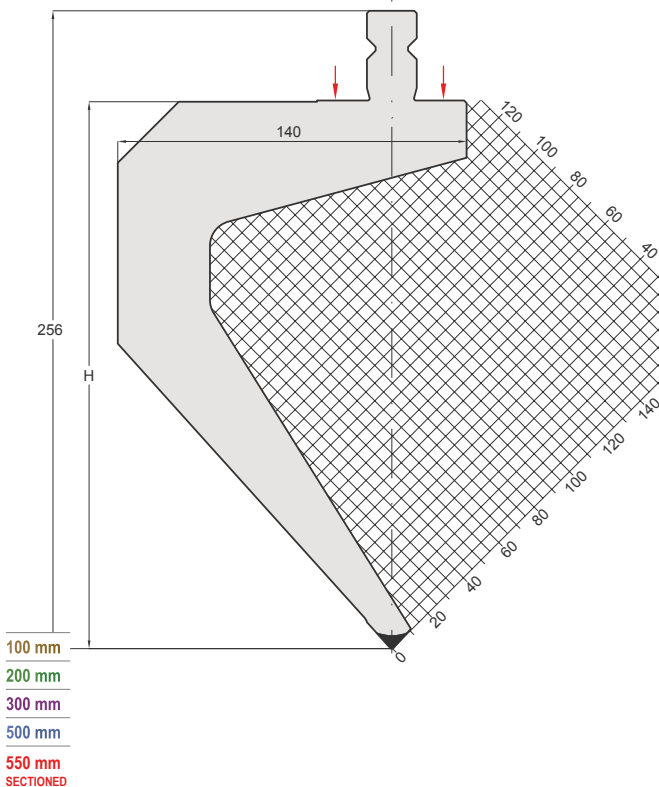

CODE	α	R	H	T/Mt	Mt
15.800	86°	1.00	300.00	80	■

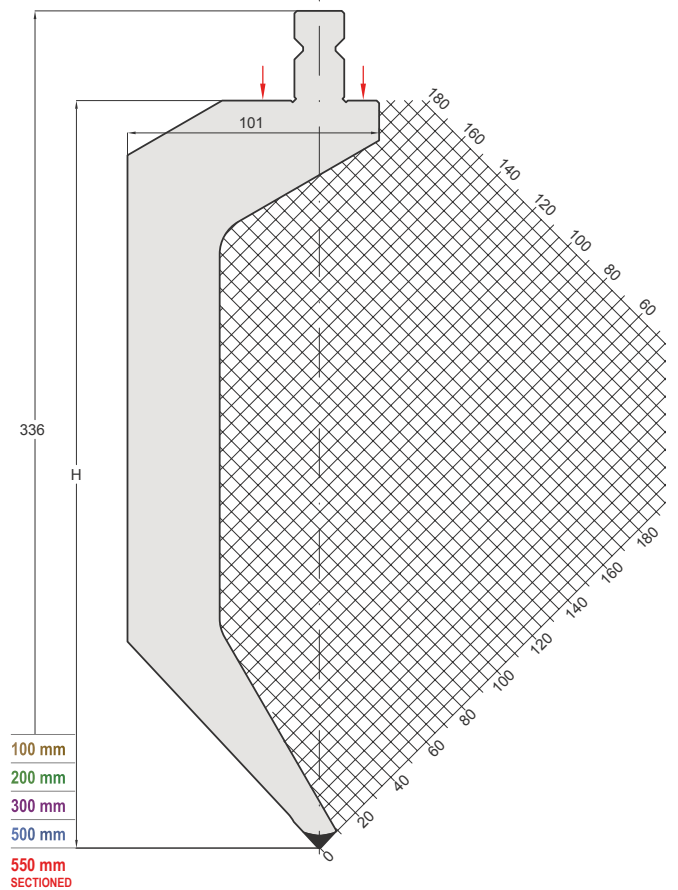

PUNZONI / PUNCHES TRUMPF STYLE 28° / 60°

CODE	α	R	H	T/Mt	Mt
15.680	60°	0.80	158.00	40	■

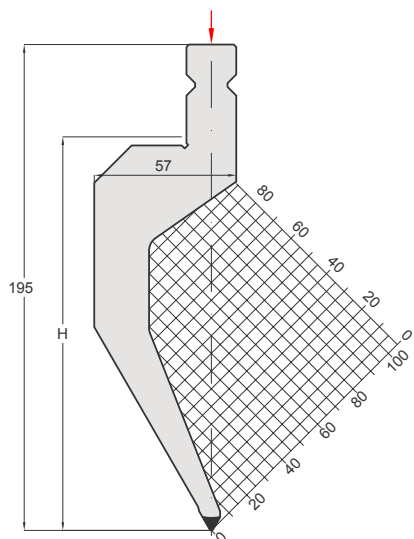

- 100 mm
- 200 mm
- 300 mm
- 500 mm
- 550 mm SECTIONED

CODE	α	R	H	T/Mt	Mt
15.320	28°	1.00	120.00	80	■

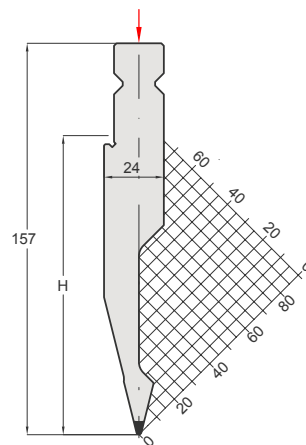

- 100 mm
- 200 mm
- 300 mm
- 500 mm
- 550 mm SECTIONED

CODE	α	R	H	T/Mt	Mt
15.450	28°	1.00	140.00	40	■

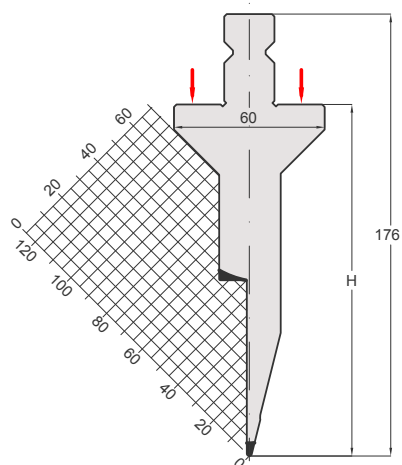

- 100 mm
- 200 mm
- 300 mm
- 500 mm
- 550 mm SECTIONED

CODE	α	R	H	T/Mt	Mt
15.610	28°	3.00	158.00	100	■

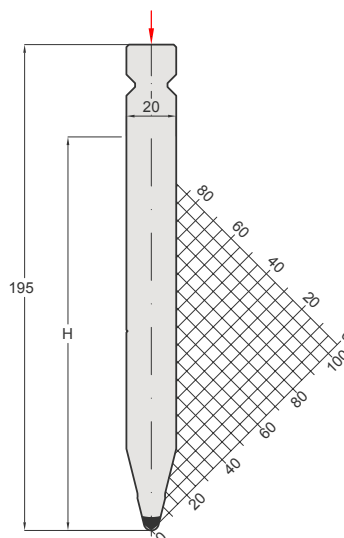

- 100 mm
- 200 mm
- 300 mm
- 500 mm
- 550 mm SECTIONED

PUNZONI / PUNCHES TRUMPF STYLE 28° / 60°

CODE	α	R	H	T/Mt	Mt
15.730	60°	4.00	220.00	130	

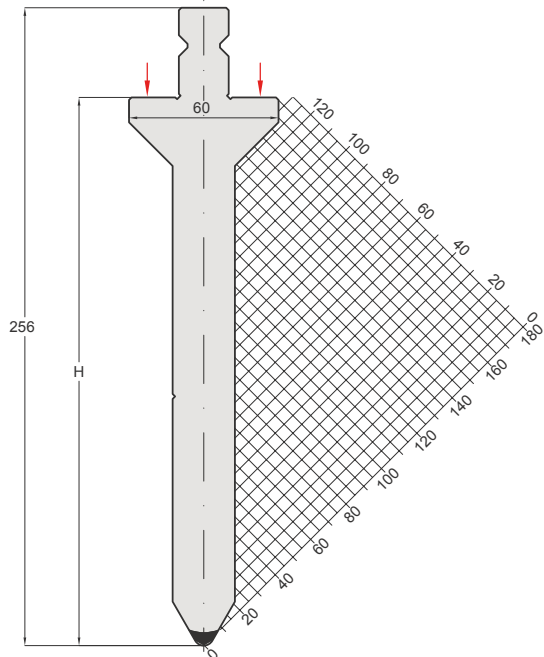

100 mm
200 mm
300 mm
500 mm
550 mm
SECTIONED

CODE	α	R	H	T/Mt	Mt
15.620	28°	1.00	158.00	80	

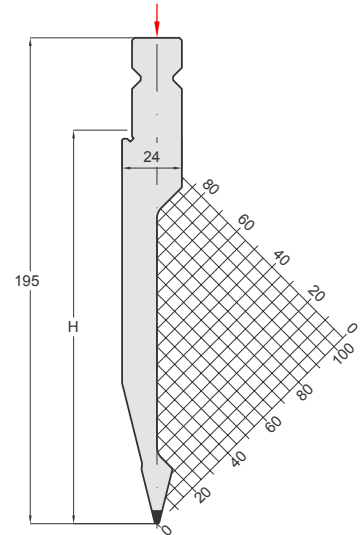

100 mm
200 mm
300 mm
500 mm
550 mm
SECTIONED

CODE	α	R	H	T/Mt	Mt
15.720	28°	1.00	220.00	80	

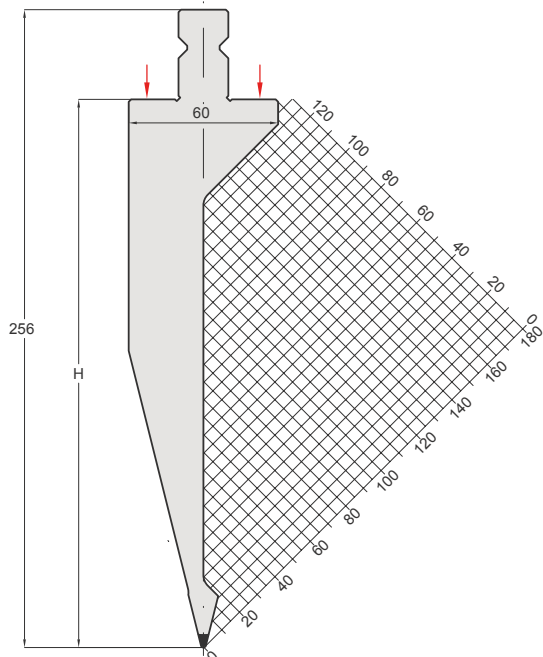

100 mm
200 mm
300 mm
500 mm
550 mm
SECTIONED

CODE	α	R	H	T/Mt	Mt
15.750	28°	1.00	240.00	40	

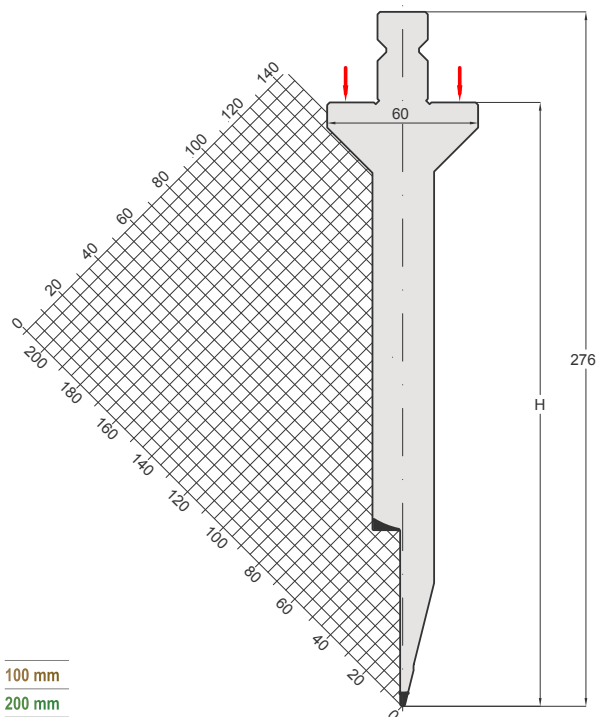

100 mm
200 mm
300 mm
500 mm
550 mm
SECTIONED

TRUMPF STYLE

MATRICI

DIES

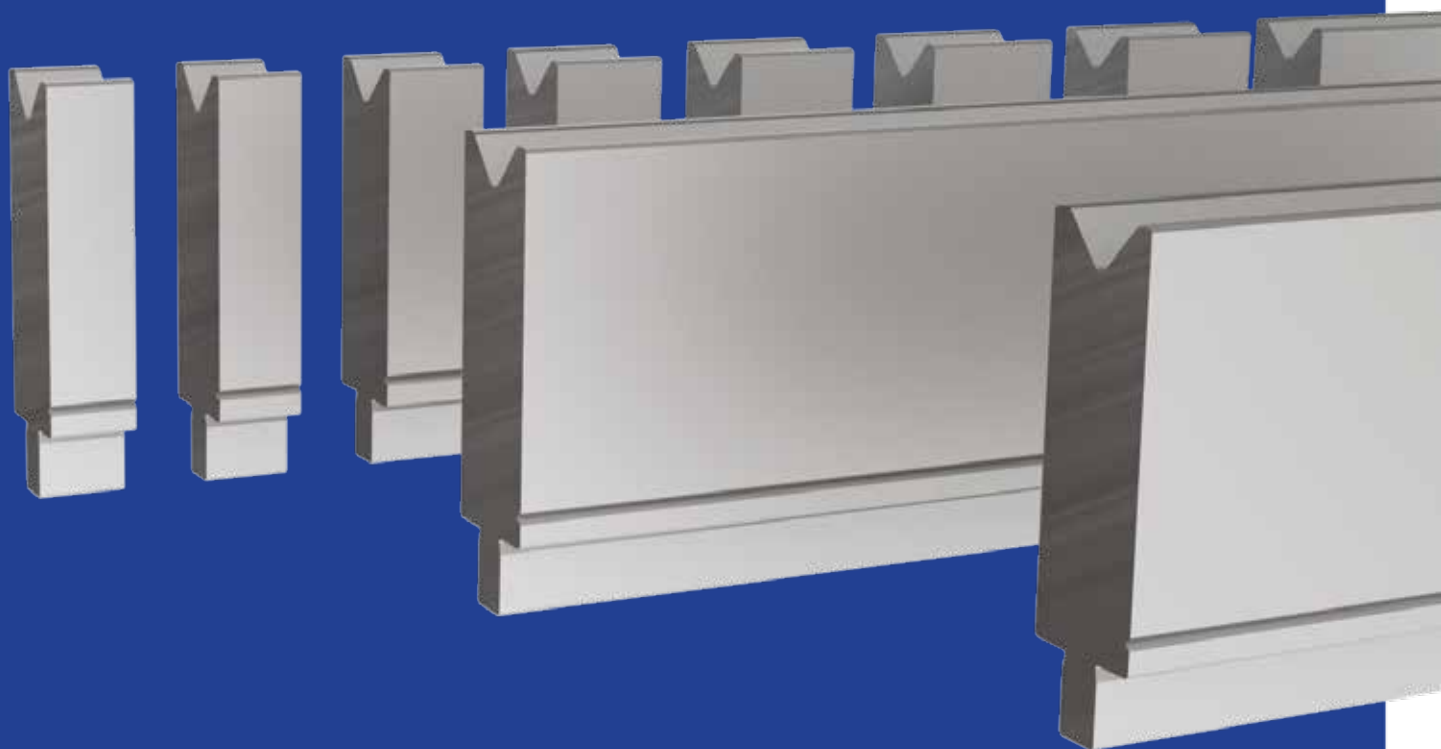

BLUE LINE

TRUMPF STYLE



MATRICI / DIES TRUMPF STYLE

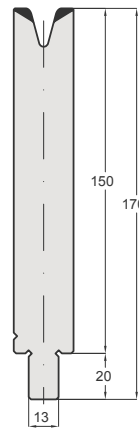
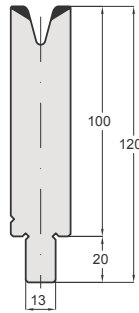
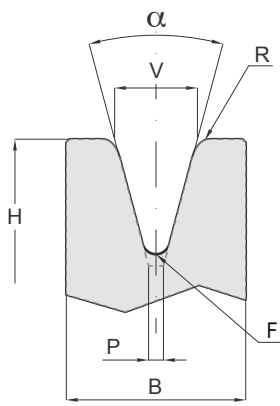

TEMPRA AD INDUZIONE 52-55 HRC
INDUCTION HARDENED 52-55 HRC

100 mm | 200 mm | 300 mm | 500 mm | 550 mm SECTIONED

LE MATRICI STANDARD SONO DISPONIBILI A MAGAZZINO NELLE LUNGHEZZE DI: 100 / 200 / 300 mm - 500 mm E FRAZIONATI (550 mm)
THE DIES ARE AVAILABLE IN THE FOLLOWING STANDARD LENGTHS: 100 / 200 / 300 mm - 500 mm AND SECTIONED (550 mm)

LEGENDA	α = ANGOLO	V = AMPIEZZA CAVA	R = RAGGIO	H = ALTEZZA	F= FONDO MATRICE	P= PIANO	B= BASE
LEGEND	α = ANGLE	V = DIE OPENING	R = RADIUS	H = HEIGHT	F= BOTTOM DIES	P= FLAT	B= WIDTH

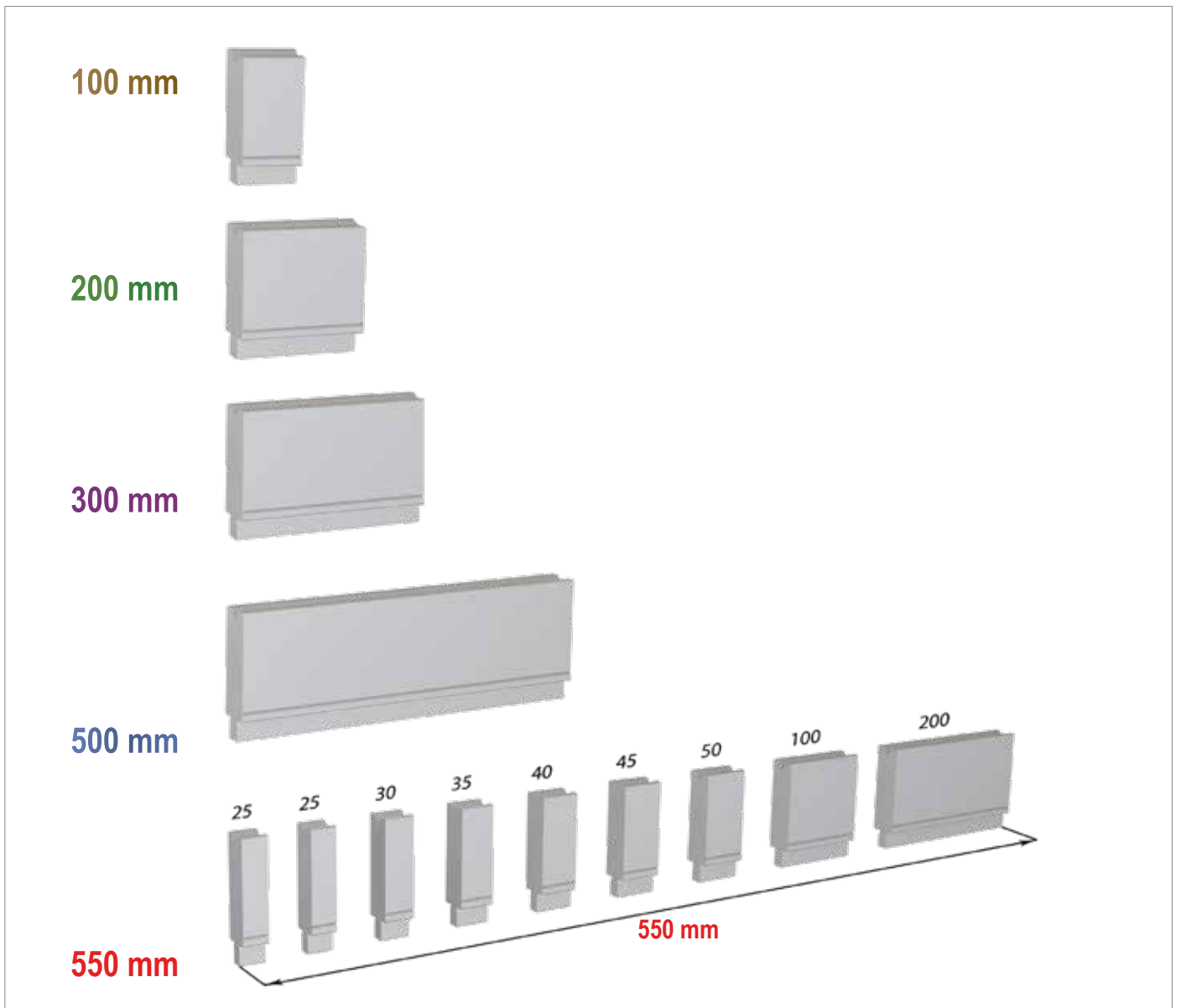

MATRICI / DIES TRUMPF STYLE H=100 / 120

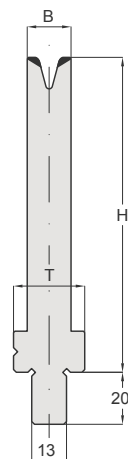
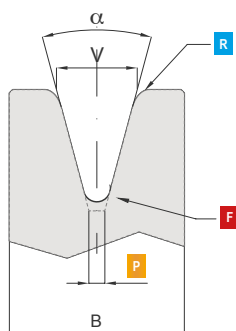

100 mm | 200 mm | 300 mm | 500 mm | 550 mm SECTIONED

LE MATRICI STANDARD SONO DISPONIBILI A MAGAZZINO NELLE LUNGHEZZE DI: 100 / 200 / 300 mm - 500 mm E FRAZIONATI (550 mm)
 THE DIES ARE AVAILABLE IN THE FOLLOWING STANDARD LENGTHS: 100 / 200 / 300 mm - 500 mm AND SECTIONED (550 mm)

LEGENDA	α = ANGOLO	V = AMPIEZZA CAVA	R = RAGGIO	H = ALTEZZA	F = FONDO MATRICE	P = PIANO	B = BASE
LEGEND	α = ANGLE	V = DIE OPENING	R = RADIUS	H = HEIGHT	F = BOTTOM DIES	P = FLAT	B = WIDTH

CODE	α	V	R	H	B	T	F	T/mt	Mt	CODE	α	V	R	H	B	T	F	T/mt	Mt
25.100	86°	4	0.60	100	8	20	R0.6	25	■	25.111	80°	60	5.00	100	75	75	R5.0	150	■
25.101	86°	6	0.60	100	20	20	R0.6	100	■	25.112	80°	70	5.00	100	85	85	R5.0	150	■
25.102	86°	8	0.80	100	20	20	R0.8	100	■	25.113	80°	80	5.00	100	100	100	R5.0	150	■
25.103	86°	10	1.00	100	20	20	R1.0	100	■	25.114	80°	90	8.00	120	110	110	R5.0	150	■
25.104	86°	12	1.00	100	25	25	R1.0	100	■	25.115	80°	100	8.00	120	120	120	R5.0	150	■
25.105	86°	16	1.60	100	30	30	R1.6	100	■	25.116	60°	120	8.00	120	145	145	P38	160	■
25.106	86°	20	2.00	100	30	30	R2.0	100	■	25.400	30°	4	0.60	100	15	20	R0.6	20	■
25.107	86°	24	2.50	100	35	35	R2.5	100	■	25.401	30°	6	0.60	100	20	20	R0.6	40	■
25.108	86°	30	3.00	100	45	45	R3.0	100	■	25.402	30°	8	1.00	100	20	20	R1.0	40	■
25.109	86°	40	3.00	100	55	55	R3.0	120	■	25.403	30°	10	1.00	100	20	20	R1.0	40	■
25.110	86°	50	3.00	100	75	75	R5.0	150	■	25.404	30°	12	1.00	100	25	25	R1.0	40	■
25.350	86°	5	0.60	100	8	20	R0.6	25	■	25.405	30°	16	1.60	100	30	30	R1.6	50	■
25.200	84°	4	0.60	100	8	20	R0.6	25	■	25.406	30°	20	2.00	100	35	35	R2.0	60	■
25.201	84°	6	0.60	100	20	20	R0.6	100	■	25.407	30°	24	2.50	100	40	40	R2.5	65	■
25.202	84°	8	0.80	100	20	20	R0.8	100	■	25.408	30°	30	3.00	100	55	55	R3.0	90	■
25.203	84°	10	1.00	100	20	20	R1.0	100	■	25.409	30°	40	5.00	100	60	60	R5.0	90	■
25.204	84°	12	1.00	100	25	25	R1.0	100	■	25.410	30°	50	5.00	100	75	75	P17	100	■
25.205	84°	16	1.60	100	30	30	R1.6	100	■	25.421	30°	6	3.00	100	20	20	R0.6	40	■
25.206	84°	20	2.00	100	30	30	R2.0	100	■	25.422	30°	8	3.00	100	20	20	R1.0	40	■
25.300	84°	5	0.60	100	8	20	R0.6	25	■	25.423	30°	10	3.00	100	20	20	R1.0	40	■
25.301	84°	6	0.60	100	10	20	R0.6	25	■	25.424	30°	12	3.00	100	25	25	R1.0	40	■
25.302	84°	8	0.80	100	12	20	R0.8	35	■	25.425	30°	16	3.00	100	30	30	R1.6	50	■
25.303	84°	10	1.00	100	14	20	R1.0	40	■	25.500	30°	5	0.60	100	15	20	R0.6	15	■
25.304	84°	12	1.00	100	16	20	R1.0	40	■	25.501	30°	6	0.60	100	16	20	R0.6	17	■
25.207	80°	24	2.50	100	35	35	R2.5	100	■	25.502	30°	8	1.00	100	17	20	R1.0	20	■
25.208	80°	30	5.00	100	45	45	R3.0	100	■	25.503	30°	10	1.00	100	18	20	R1.0	20	■
25.209	80°	40	5.00	100	55	55	R3.0	120	■	25.504	30°	12	1.00	100	21.5	25	R1.0	25	■
25.210	80°	50	5.00	100	65	65	R5.0	150	■										

MATRICI / DIES TRUMPF STYLE H=150

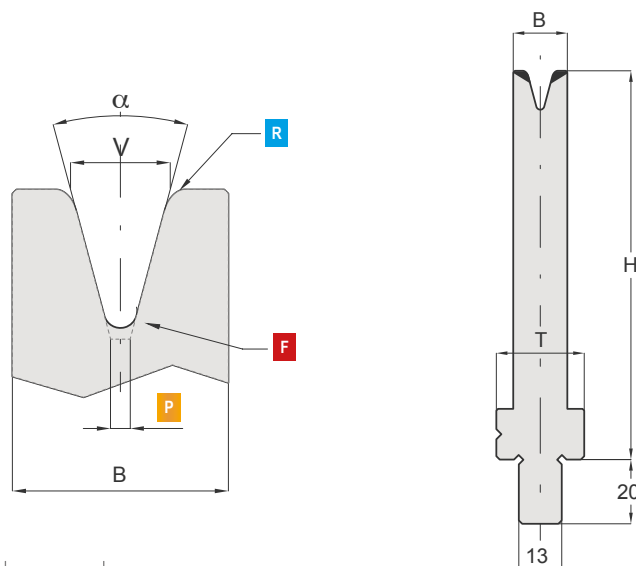

100 mm | 200 mm | 300 mm | 500 mm | 550 mm SECTIONED

LE MATRICI STANDARD SONO DISPONIBILI A MAGAZZINO NELLE LUNGHEZZE DI: 100 / 200 / 300 mm - 500 mm E FRAZIONATI (550 mm)
 THE DIES ARE AVAILABLE IN THE FOLLOWING STANDARD LENGTHS: 100 / 200 / 300 mm - 500 mm AND SECTIONED (550 mm)

LEGENDA	α = ANGOLO	V = AMPIEZZA CAVA	R = RAGGIO	H = ALTEZZA	F= FONDO MATRICE	P= PIANO	B= BASE
LEGEND	α = ANGLE	V = DIE OPENING	R = RADIUS	H = HEIGHT	F= BOTTOM DIES	P= FLAT	B= WIDTH

CODE	α	V	R	H	B	T	F	T/mt	Mt
25.601	86°	6	0.60	150	20	20	R0.6	100	■
25.602	86°	8	0.80	150	20	20	R0.8	100	■
25.603	86°	10	1.00	150	20	20	R1.0	100	■
25.604	86°	12	1.00	150	25	25	R1.0	100	■
25.605	86°	16	1.60	150	30	30	R1.6	100	■
25.606	86°	20	2.00	150	30	30	R2.0	100	■
25.607	86°	24	2.50	150	35	35	R2.5	100	■
25.621	84°	6	0.60	150	20	20	R0.6	100	■
25.622	84°	8	0.80	150	20	20	R0.8	100	■
25.623	84°	10	1.00	150	20	20	R1.0	100	■
25.624	84°	12	1.00	150	25	25	R1.0	100	■
25.625	84°	16	1.60	150	30	30	R1.6	100	■
25.626	84°	20	2.00	150	30	30	R2.0	100	■
25.627	80°	24	2.50	150	35	35	R2.5	100	■
25.628	80°	30	5.00	150	45	45	R3.0	100	■
25.629	80°	40	5.00	150	55	55	R3.0	100	■
25.630	80°	50	5.00	150	65	65	R5.0	100	■
25.901	30°	6	0.60	150	20	20	R0.6	40	■
25.902	30°	8	1.00	150	20	20	R1.0	40	■
25.903	30°	10	1.00	150	20	20	R1.0	40	■
25.904	30°	12	1.00	150	25	25	R1.0	40	■
25.905	30°	16	1.60	150	30	30	R1.6	50	■
25.906	30°	20	2.00	150	35	35	R2.0	60	■
25.907	30°	24	2.50	150	40	40	R2.5	65	■
25.908	30°	30	3.00	150	55	55	R3.0	90	■
25.909	30°	40	5.00	150	60	60	R5.0	90	■



TRUMPF STYLE

PIEGASCHIACCIA

HEMMING TOOLS

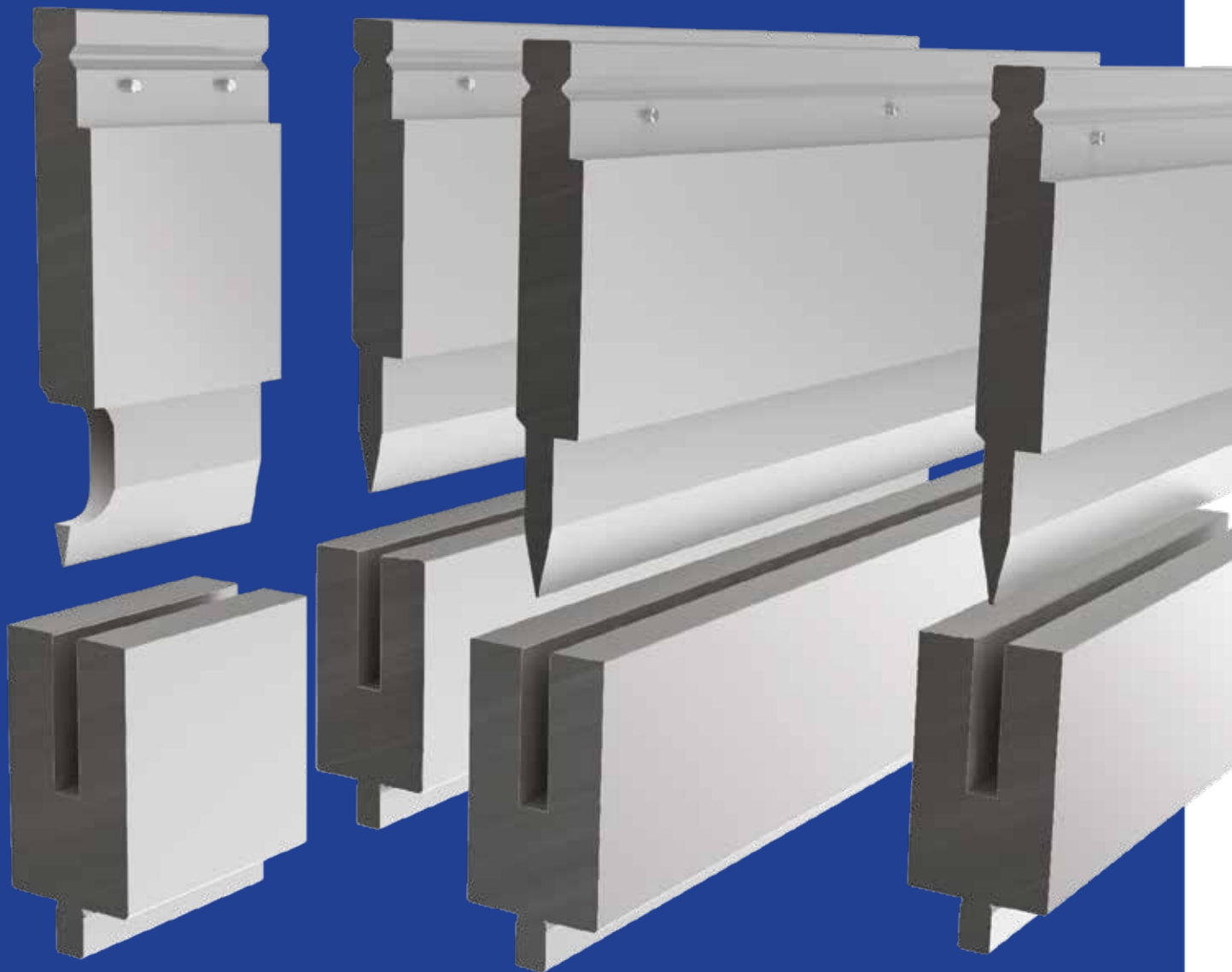

BLUE LINE

TRUMPF STYLE



PIEGASCHIACCIA / HEMMING TOOLS TRUMPF STYLE

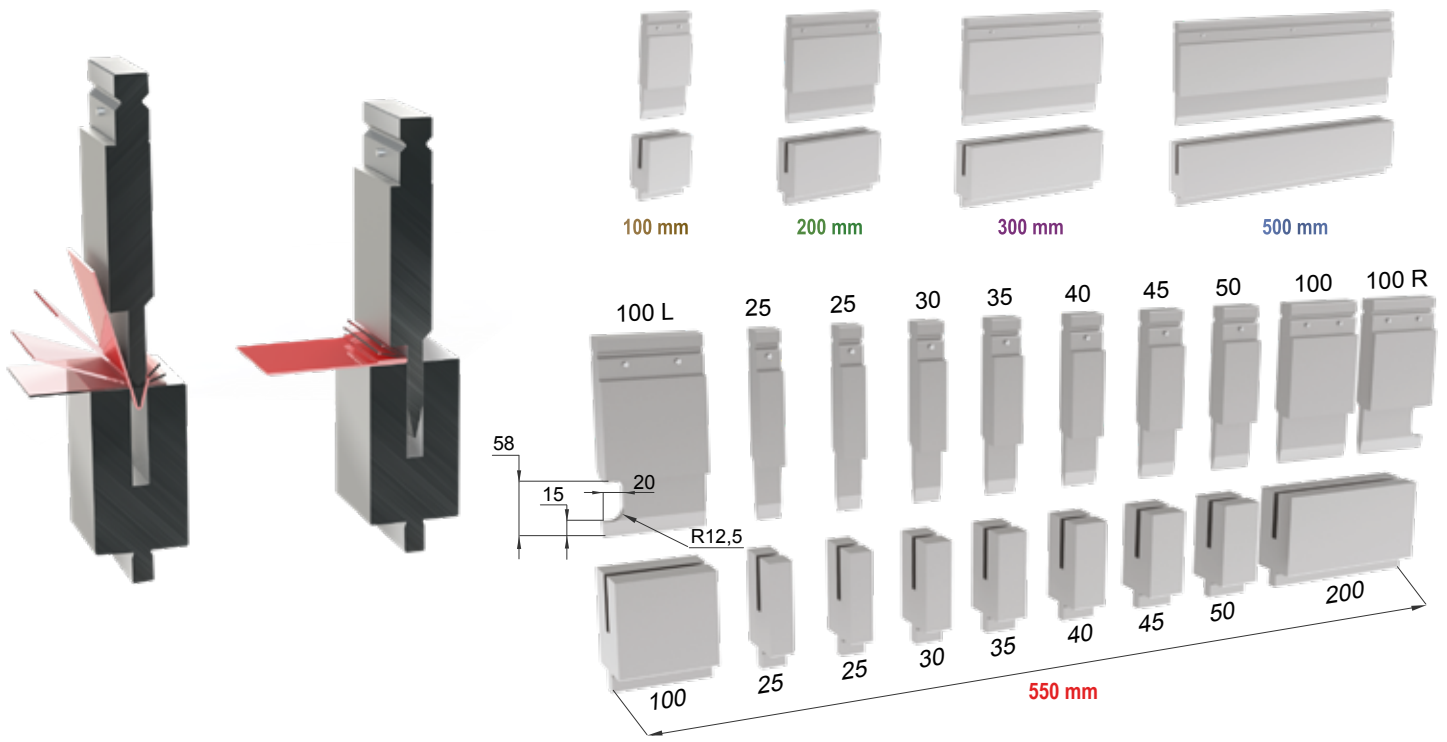

100 mm | 200 mm | 300 mm | 500 mm | 550 mm SECTIONED

IL CARICO MASSIMO DELLE SCARPETTE CORRISPONDE AL 50% DEL CARICO MASSIMO INDICATO SUL PUNZONE.
 THE MAX LOAD OF THE HORN EXTENSIONS IS 50% OF THE MAX LOAD OF THE PUNCH.

MATERIAL ACC.R ~ 40 Kg/MM ²					MATERIAL ACC.R ~ 70 Kg/MM ²				
S (mm)	(t/m)	T (mm)	(t/m)	2S(mm)	S (mm)	(t/m)	T (mm)	(t/m)	2S(mm)
0,6	9	3	23	1,2	0,6	15	3	35	1,2
0,8	12	3	32	1,6	0,8	20	3	50	1,6
1,0	15	3,5	40	2,0	1,0	25	3,5	60	2,0
1,25	17	3,5	50	2,5	1,25	26	3,5	80	2,5
1,5	22	4,6	63	3,0	1,5	38	4,6	95	3,0
2,0	30	5,5	80	4,0	2,0	50	5,5	130	4,0
2,5	55	6,5	90	5,0					
3,0	70	8,0	100	6,0					



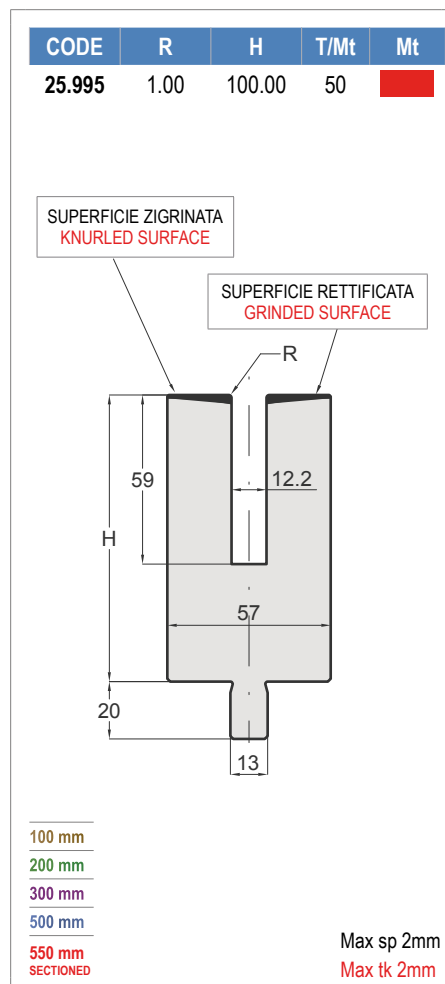
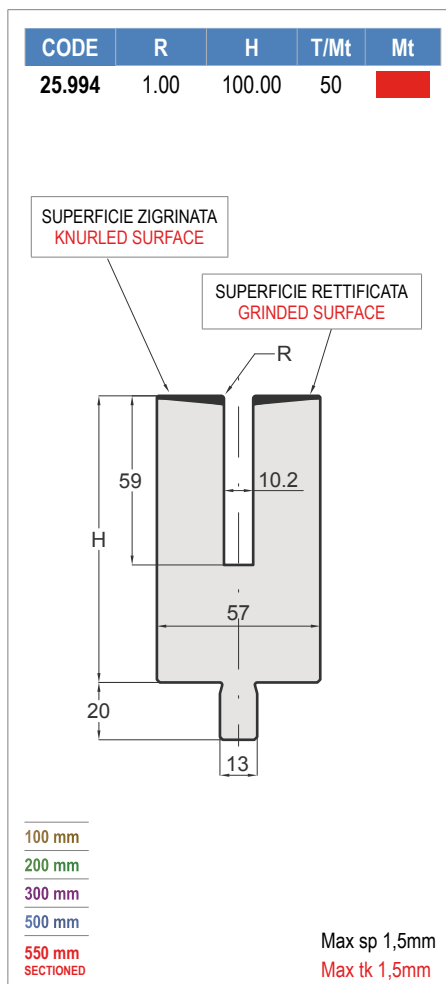
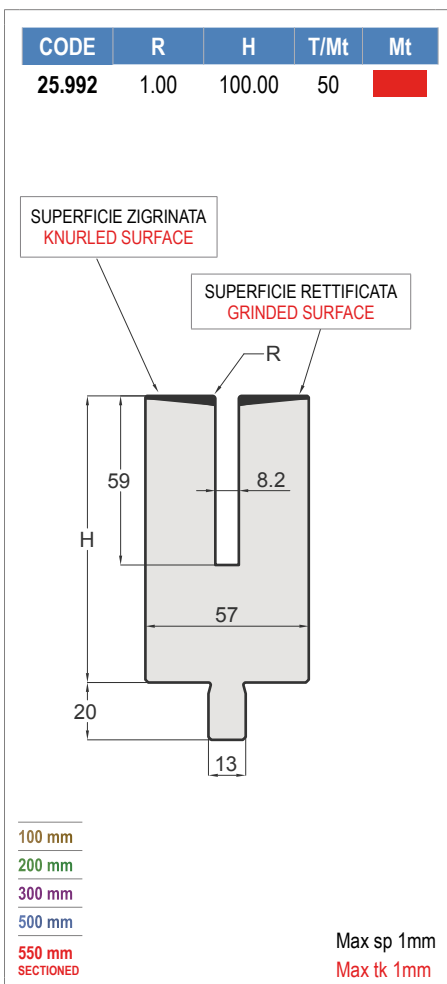
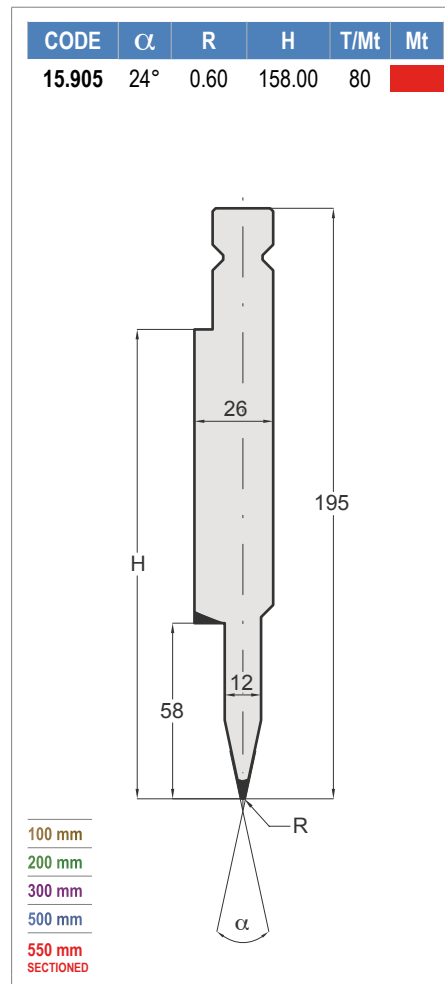
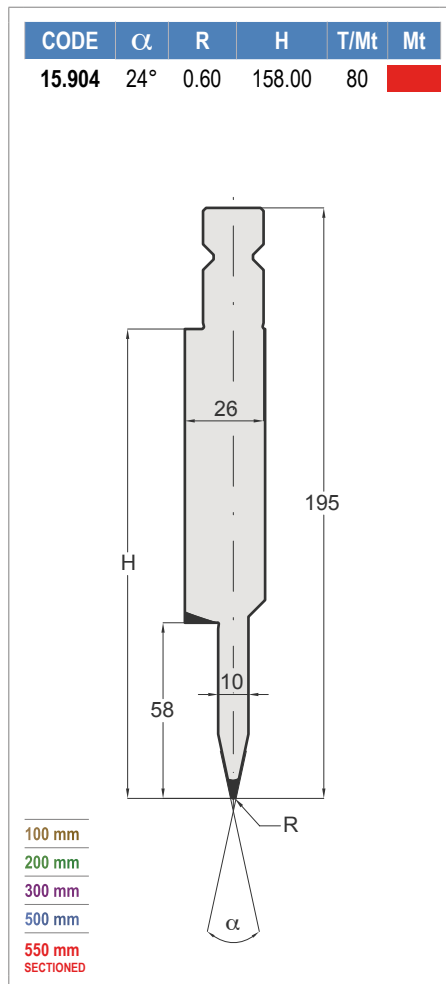
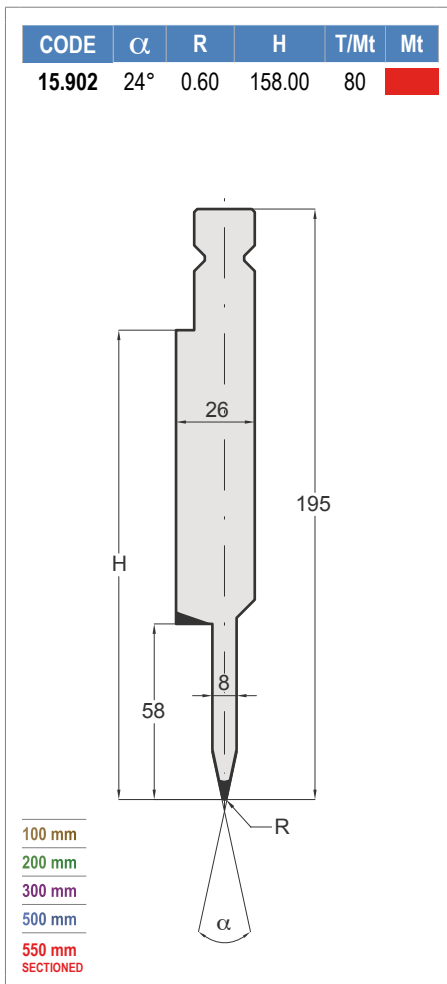

CODE	H	T/Mt	Mt
60.120	100.00	120	

100 mm
200 mm
300 mm
500 mm
550 mm SECTIONED

CODE
70.800

CODICE FORATURA MATRICI PER APPLICARE L'INSERTO SCHIACCIATORE 60.120

CODE OF DRILL HOLES IN THE DIE FOR USE OF SCREWABLE FLATTENING DIE 60.120

100 mm
200 mm
300 mm
500 mm
550 mm SECTIONED

CODE	H	T/Mt	Mt
60.130	150.00	120	

100 mm
200 mm
300 mm
500 mm
550 mm SECTIONED

CODE
70.810

CODICE FORATURA MATRICI PER APPLICARE L'INSERTO SCHIACCIATORE 60.130

CODE OF DRILL HOLES IN THE DIE FOR USE OF SCREWABLE FLATTENING DIE 60.130

100 mm
200 mm
300 mm
500 mm
550 mm SECTIONED

WILA STYLE

PUNZONI

PUNCHES



PLATINUM LINE

WILA STYLE

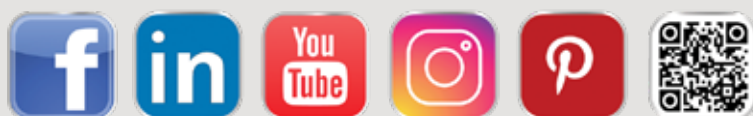

PUNZONI / PUNCHES WILA STYLE

SPINTA IN TESTA
FORCE ON HEAD

SPINTA SULLE SPALLE
FORCE ON SHOULDERS

IL CARICO MASSIMO DELLE SCARPETTE CORRISPONDE AL 50% DEL CARICO MASSIMO INDICATO SUL PUNZONE.
THE MAX LOAD OF THE HORN EXTENSIONS IS 50% OF THE MAX LOAD OF THE PUNCH.

TEMPRA AD INDUZIONE 52-55 HRC
INDUCTION HARDENED 52-55 HRC

LEGENDA	α = ANGOLO	R = RAGGIO	H = ALTEZZA
LEGEND	α = ANGLE	R = RADIUS	H = HEIGHT

I PUNZONI STANDARD SONO DISPONIBILI A MAGAZZINO NELLE LUNGHEZZE DI: 100 / 200 / 300 mm - 515 mm E FRAZIONATI (550 mm)
THE PUNCHES ARE AVAILABLE IN THE FOLLOWING STANDARD LENGTHS: 100 / 200 / 300 mm - 515 mm AND SECTIONED (550 mm)

MONTAGGIO E SMONTAGGIO LATERALE DEGLI UTENSILI
SIDE INSTALLATION AND DISINSTALLATION OF TOOLS

SPINTA IN TESTA
FORCE ON HEAD

SPINTA SULLE SPALLE
FORCE ON SHOULDERS

CODE
70.130

SPARE PARTS

MONTAGGIO E SMONTAGGIO FRONTALE DEGLI UTENSILI
FRONT INSTALLATION AND DISINSTALLATION OF TOOLS

SPINTA IN TESTA
FORCE ON HEAD

SPINTA SULLE SPALLE
FORCE ON SHOULDERS

SOLO PER STAMPI FINO ≤ 12,5 KG
ONLY FOR TOOLS ≤ 12,5 KG

70.714		19.024	19.034		
70.715		19.021	19.031	19.224	
70.716		19.022	19.032		
70.718		19.023	19.033	19.233	19.235
70.719		19.226			

PUNZONI / PUNCHES WILA STYLE 28° / 45° / 60° / 80° / 86°

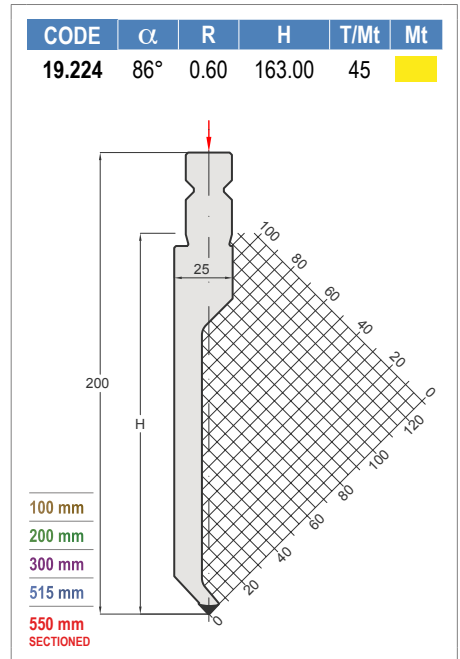
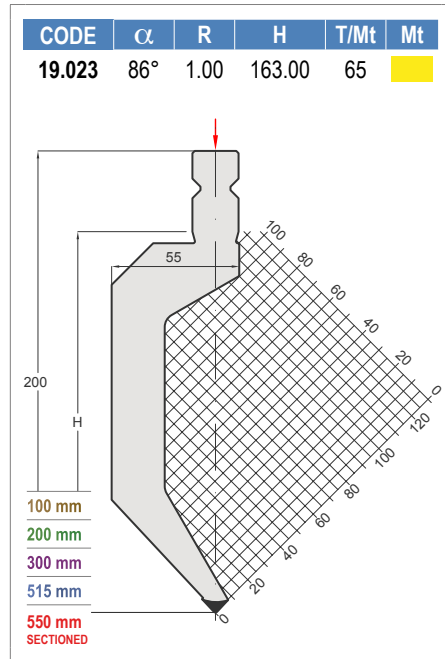
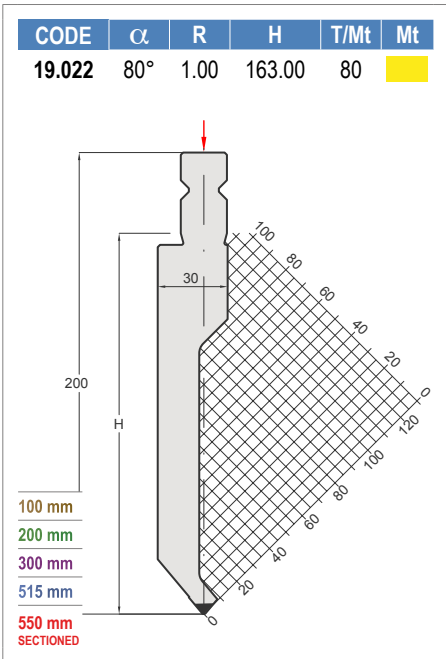
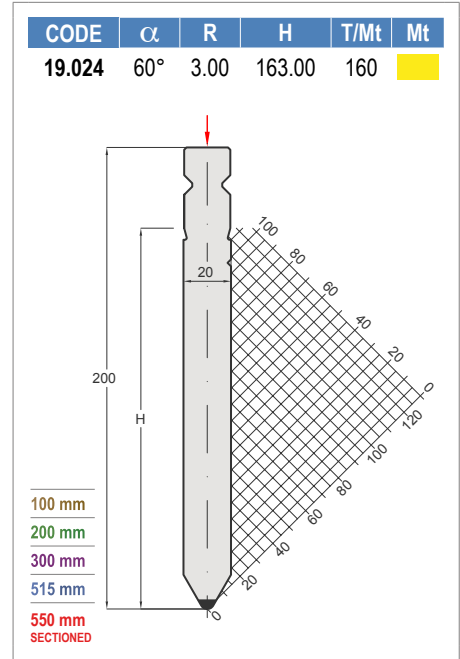
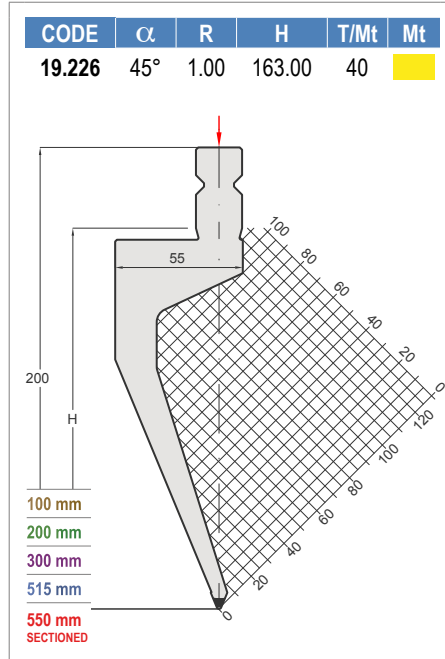
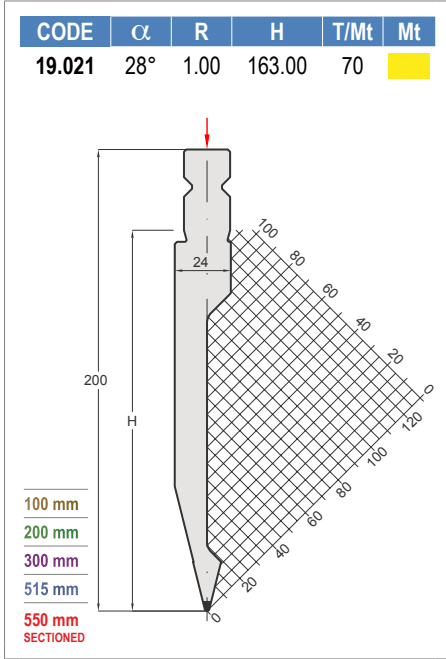

PUNZONI / PUNCHES WILA STYLE 28° / 60° / 80° / 86°

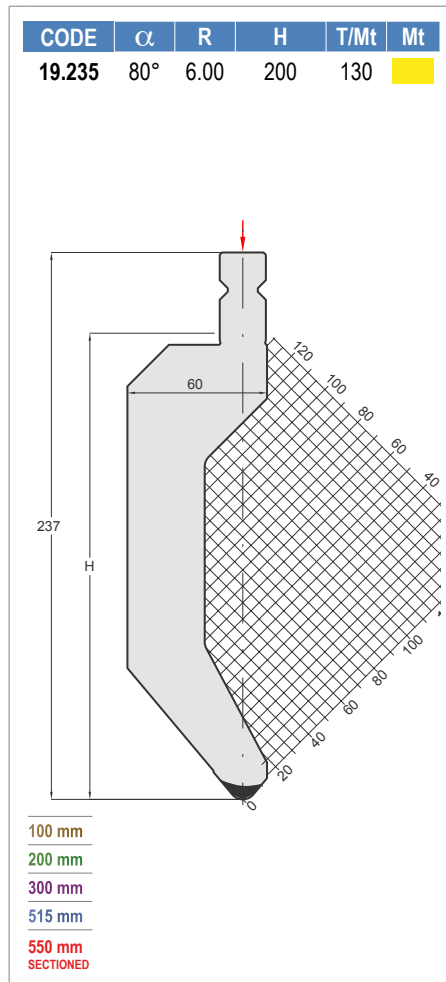
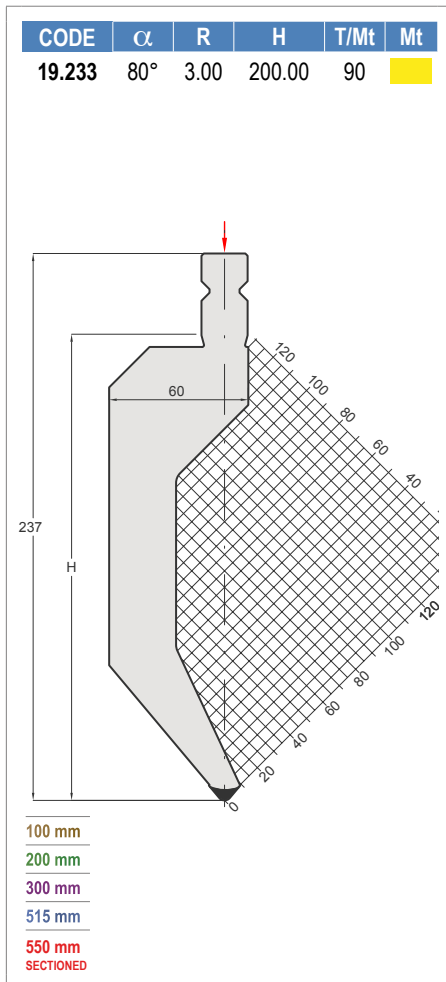
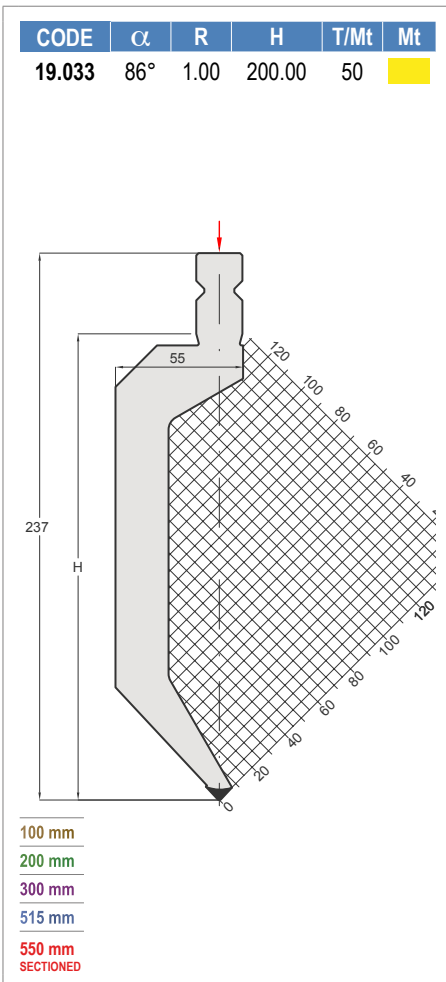
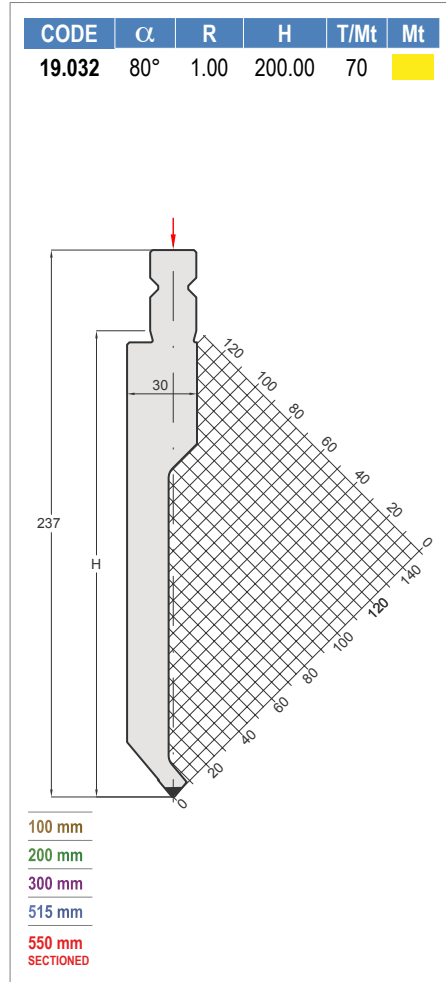
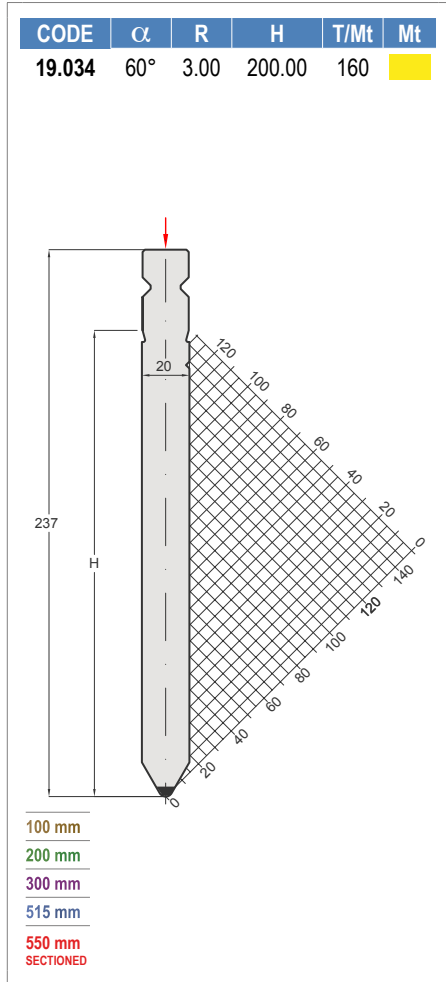
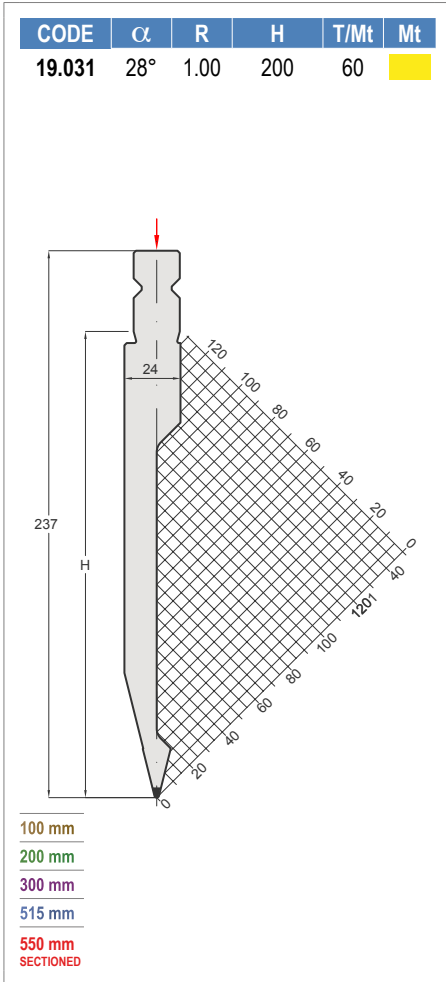

WILA STYLE

MATRICI

DIES

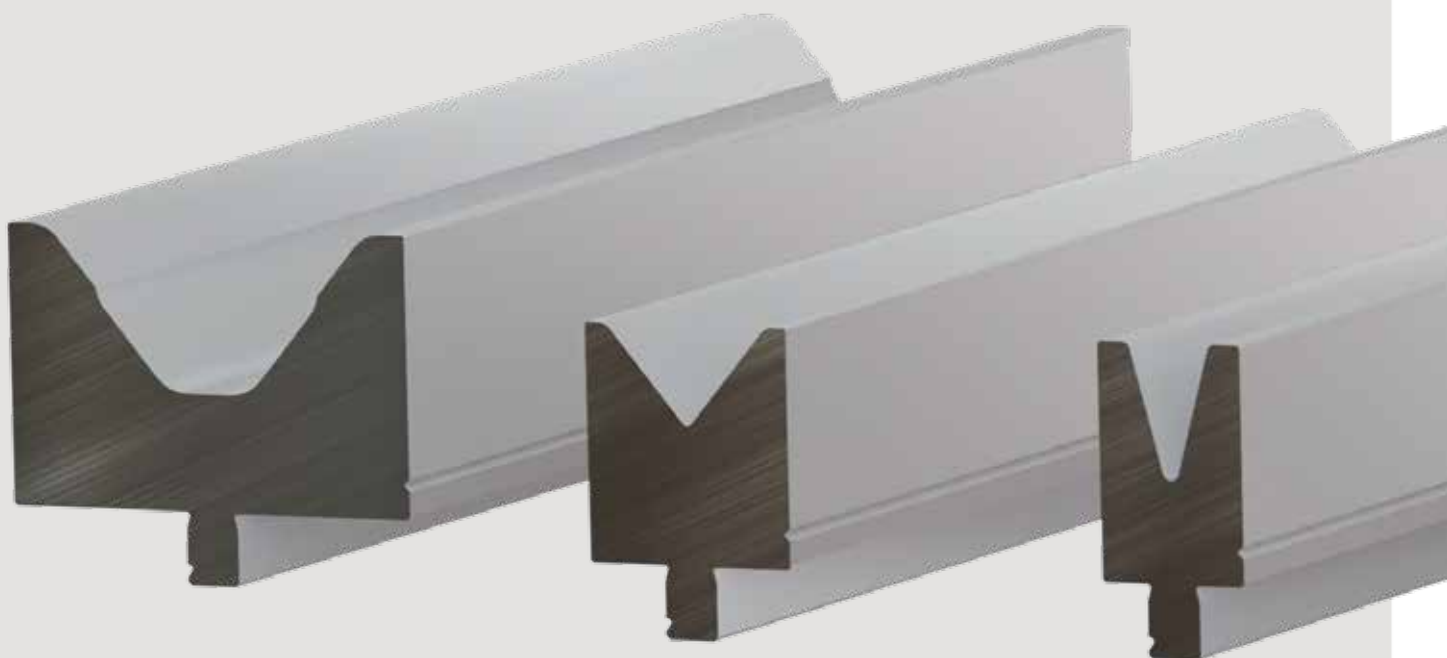

PLATINUM LINE

WILA STYLE

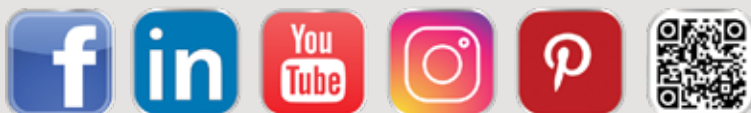

MATRICI / DIES WILA STYLE H=55 / H=65

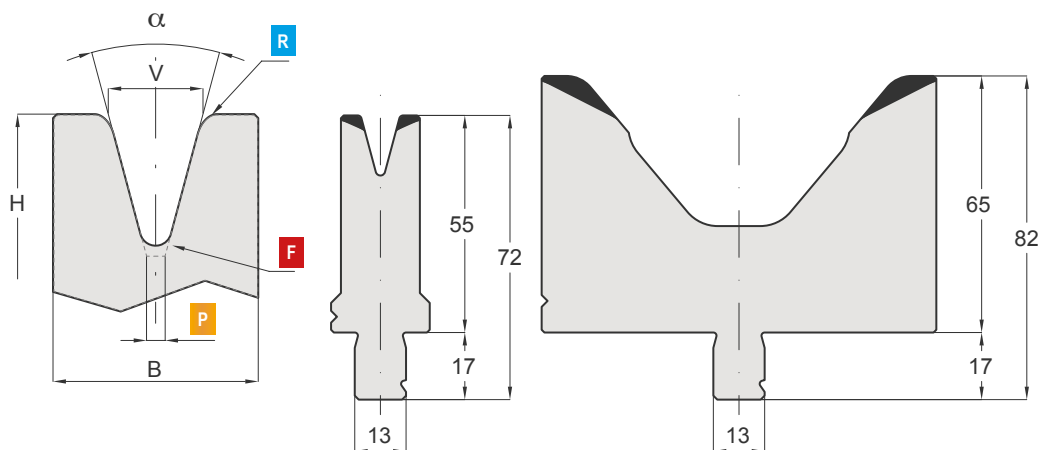

TEMPRA AD INDUZIONE 52-55 HRC
INDUCTION HARDENED 52-55 HRC

100 mm | 200 mm | 300 mm | 515 mm | 550 mm SECTIONED

LE MATRICI STANDARD SONO DISPONIBILI A MAGAZZINO NELLE LUNGHEZZE DI: 100 / 200 / 300 mm - 515 mm E FRAZIONATI (550 mm)
THE DIES ARE AVAILABLE IN THE FOLLOWING STANDARD LENGTHS: 100 / 200 / 300 mm - 515 mm AND SECTIONED (550 mm)

LEGENDA	α = ANGOLO	V = AMPIEZZA CAVA	R = RAGGIO	H = ALTEZZA	F= FONDO MATRICE	P= PIANO	B= BASE
LEGEND	α = ANGLE	V = DIE OPENING	R = RADIUS	H = HEIGHT	F= BOTTOM DIES	P= FLAT	B= WIDTH

CODE	α	V	R	H	B	T	F	T/mt	Mt
29.524	86°	4	0.40	55	10	25	R0.6	45	■
29.521	86°	6	1.00	55	16	25	R0.8	120	■
29.510	86°	8	1.00	55	16	25	R0.8	120	■
29.522	86°	10	1.00	55	20	25	R1.0	120	■
29.511	86°	12	1.00	55	20	25	R1.2	120	■
29.512	86°	16	1.50	55	25	25	R1.2	120	■
29.523	86°	20	2.00	55	30	30	R1.2	120	■
29.513	80°	24	2.50	55	35	35	R1.2	125	■
29.514	80°	30	3.00	55	40	40	R1.2	125	■
29.515	80°	40	4.00	55	50	50	R1.2	125	■
29.535	80°	50	5.00	55	75	75	R6.0	150	■
29.517	80°	80	8.00	65	100	100	P20.1	150	■
29.561	30°	6	1.00	55	16	25	R1.0	80	■
29.551	30°	8	1.00	55	16	25	R1.2	80	■
29.562	30°	10	1.00	55	20	25	R1.2	80	■
29.552	30°	12	1.00	55	20	25	R1.2	80	■
29.553	30°	16	1.50	55	30	30	R1.2	80	■
29.563	30°	20	2.00	55	35	35	R2.0	80	■
29.554	30°	24	2.50	55	40	40	R4.5	80	■



WILA STYLE

PIEGASCHIACCIA

HEMMING TOOLS



PLATINUM LINE

WILA STYLE

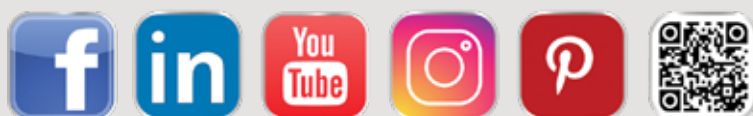

PIEGASCHIACCIA / HEMMING TOOLS WILA STYLE

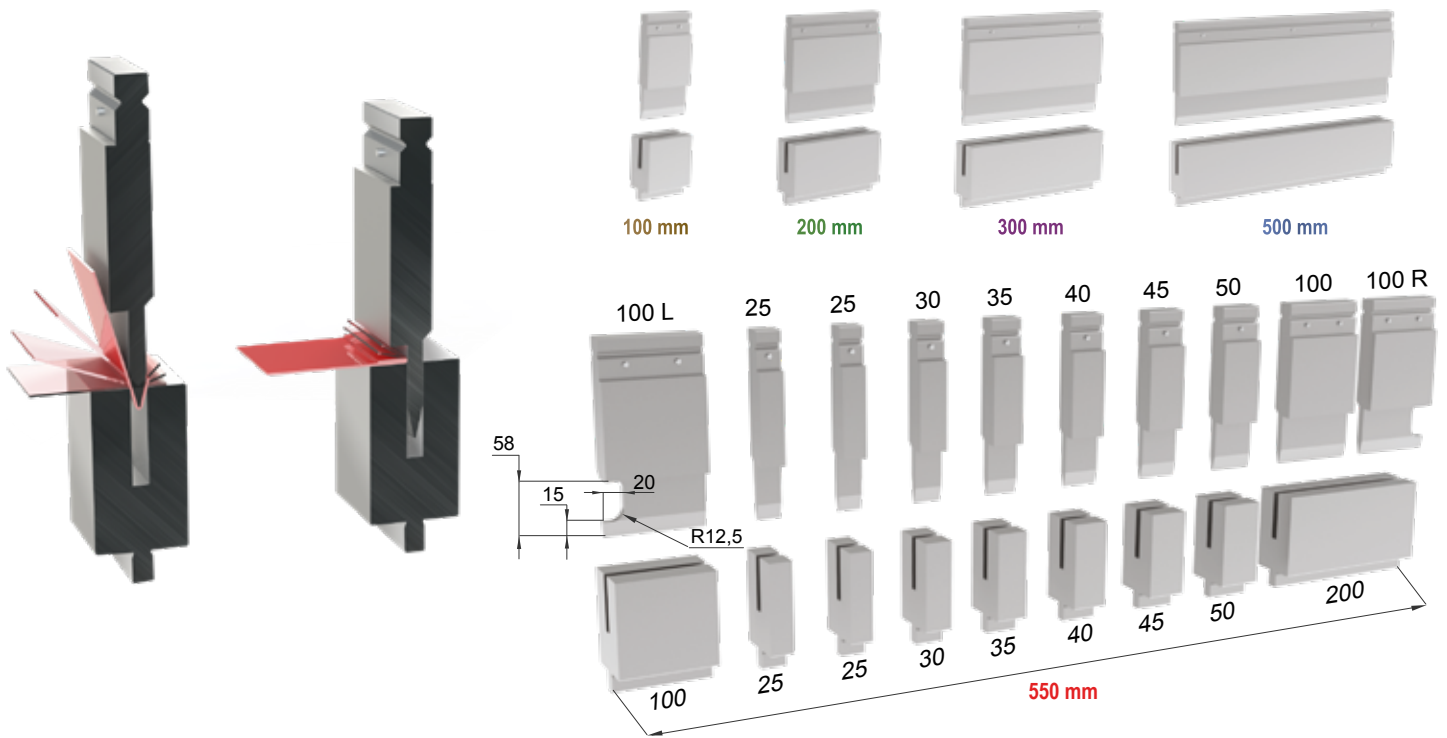

100 mm | 200 mm | 300 mm | 500 mm | 550 mm SECTIONED

IL CARICO MASSIMO DELLE SCARPETTE CORRISPONDE AL 50% DEL CARICO MASSIMO INDICATO SUL PUNZONE.
 THE MAX LOAD OF THE HORN EXTENSIONS IS 50% OF THE MAX LOAD OF THE PUNCH.

MATERIAL ACC.R ~ 40 Kg/MM ²					MATERIAL ACC.R ~ 70 Kg/MM ²				
MATERIAL ACC.R ~ 40 Kg/MM ²					MATERIAL ACC.R ~ 70 Kg/MM ²				
S (mm)	(t/m)	T (mm)	(t/m)	2S(mm)	S (mm)	(t/m)	T (mm)	(t/m)	2S(mm)
0,6	9	3	23	1,2	0,6	15	3	35	1,2
0,8	12	3	32	1,6	0,8	20	3	50	1,6
1,0	15	3,5	40	2,0	1,0	25	3,5	60	2,0
1,25	17	3,5	50	2,5	1,25	26	3,5	80	2,5
1,5	22	4,6	63	3,0	1,5	38	4,6	95	3,0
2,0	30	5,5	80	4,0	2,0	50	5,5	130	4,0
2,5	55	6,5	90	5,0					
3,0	70	8,0	100	6,0					

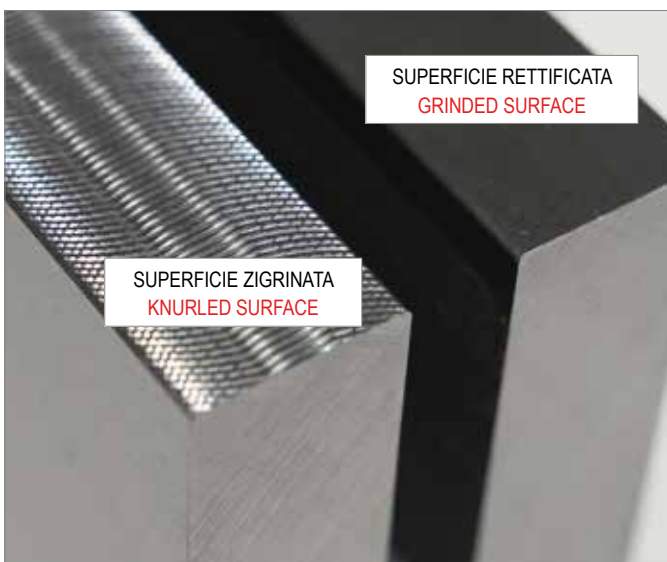

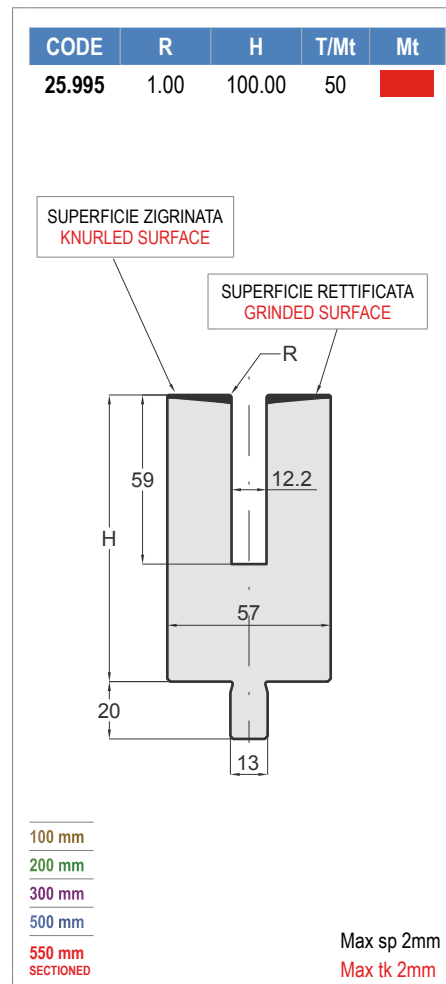
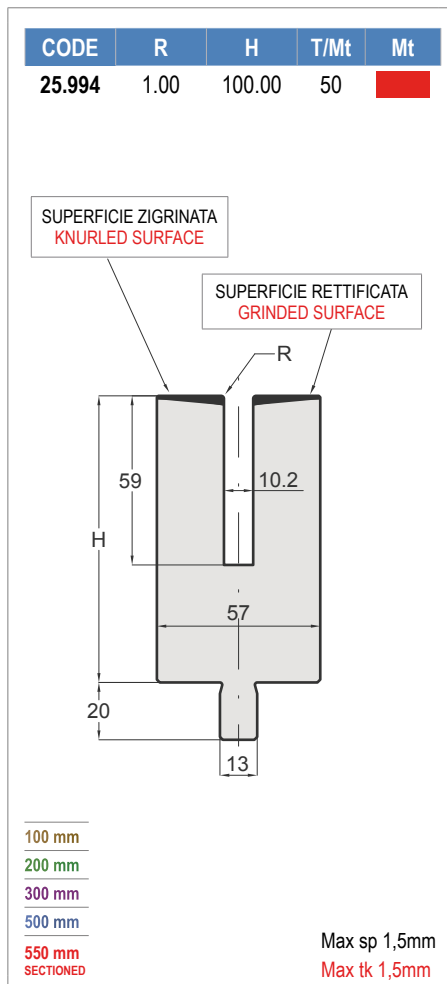
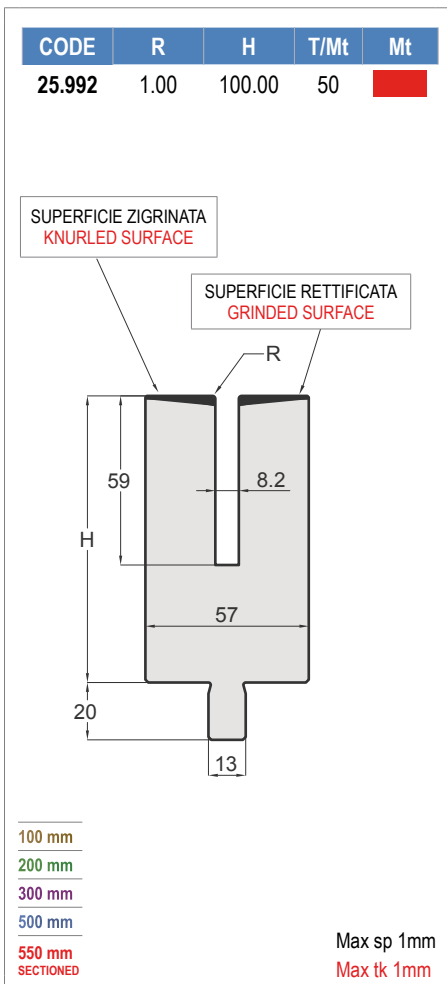
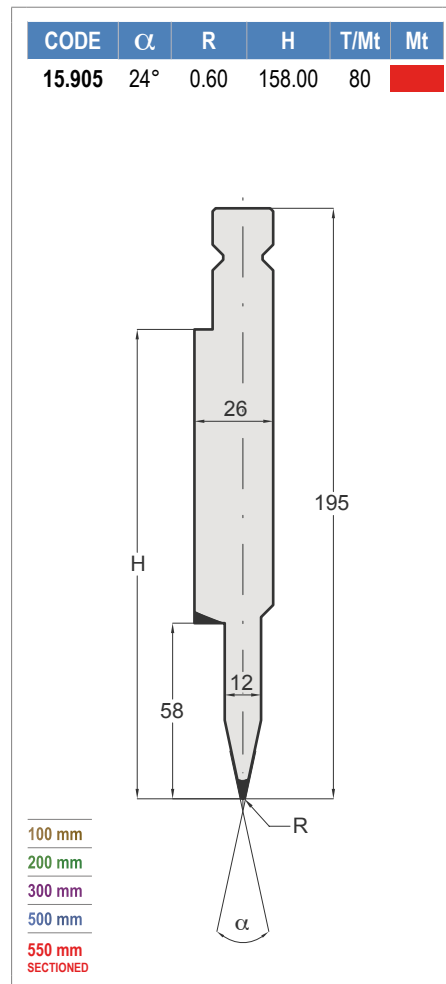
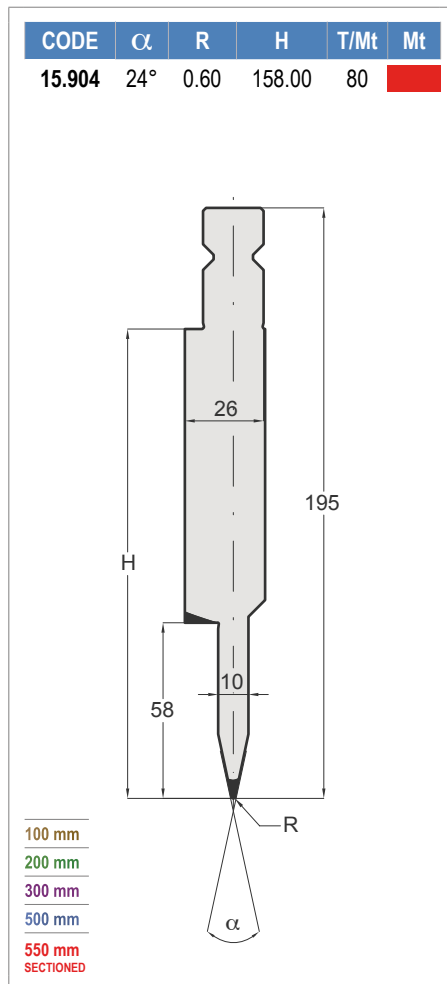
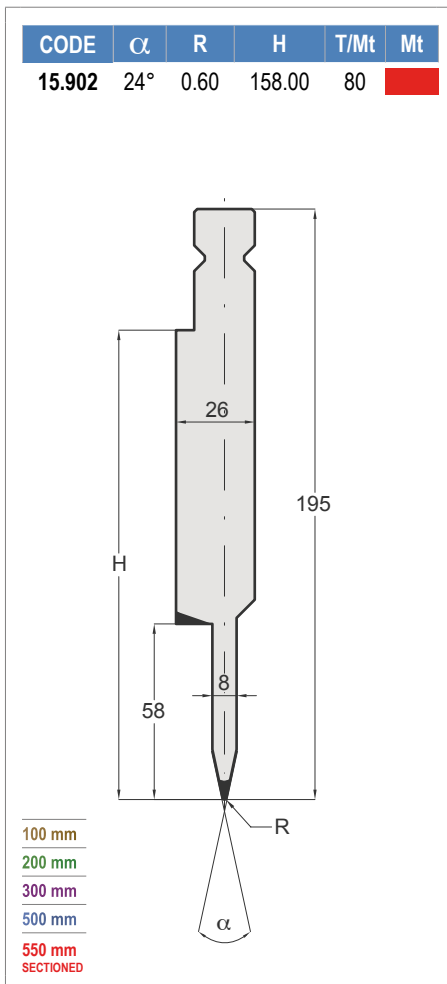



BYSTRONIC - BEYELER STYLE

PUNZONI

PUNCHES



ORANGE LINE

BYSTRONIC - BEYELER STYLE



PUNZONI / PUNCHES *EURO - BYSTRONIC - BEYELER STYLE*

I PUNZONI STANDARD SONO DISPONIBILI A MAGAZZINO NELLE LUNGHEZZE DI: 100 / 200 / 300 mm - 500 mm E FRAZIONATI (550 mm)
 THE PUNCHES ARE AVAILABLE IN THE FOLLOWING STANDARD LENGTHS: 100 / 200 / 300 mm - 500 mm AND SECTIONED (550 mm)

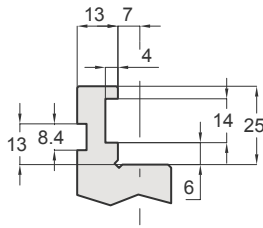
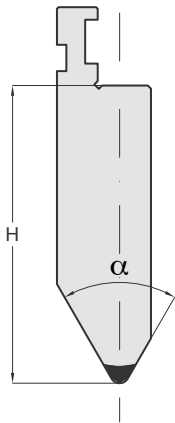

**EURO-BEYELER
SAFAN**

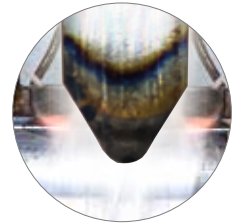

**TEMPRA AD INDUZIONE 52-55 HRC
INDUCTION HARDENED 52-55 HRC**

LEGENDA	α = ANGOLO	R = RAGGIO	H = ALTEZZA
LEGEND	α = ANGLE	R = RADIUS	H = HEIGHT

100 mm



200 mm



300 mm



500mm

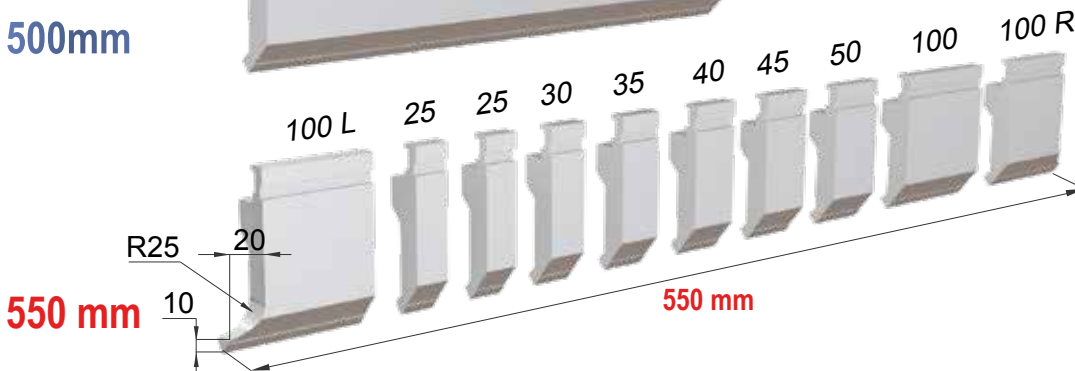

IL CARICO MASSIMO DELLE SCARPETTE CORRISPONDE AL 50% DEL CARICO MASSIMO INDICATO SUL PUNZONE.
 THE MAX LOAD OF THE HORN EXTENSIONS IS 50% OF THE MAX LOAD OF THE PUNCH.

PUNZONI / PUNCHES *EURO - BYSTRONIC - BEYELER STYLE* 28° / 60° / 80° / 86°

CODE	α	R	H	T/Mt	Mt
14.040	86°	1.00	95.00	75	■

100 mm
200 mm
300 mm
500 mm
550 mm SECTIONED

CODE	α	R	H	T/Mt	Mt
14.020	80°	1.00	95.00	75	■

100 mm
200 mm
300 mm
500 mm
550 mm SECTIONED

CODE	α	R	H	T/Mt	Mt
14.010	60°	3.00	95.00	100	■

100 mm
200 mm
300 mm
500 mm
550 mm SECTIONED

CODE	α	R	H	T/Mt	Mt
14.030	28°	1.00	95.00	70	■

100 mm
200 mm
300 mm
500 mm
550 mm SECTIONED

CODE	α	R	H	T/Mt	Mt
14.060	80°	1.00	175.00	80	■

100 mm
200 mm
300 mm
500 mm
550 mm SECTIONED

CODE	α	R	H	T/Mt	Mt
14.050	28°	1.00	175.00	100	■

100 mm
200 mm
300 mm
500 mm
550 mm SECTIONED

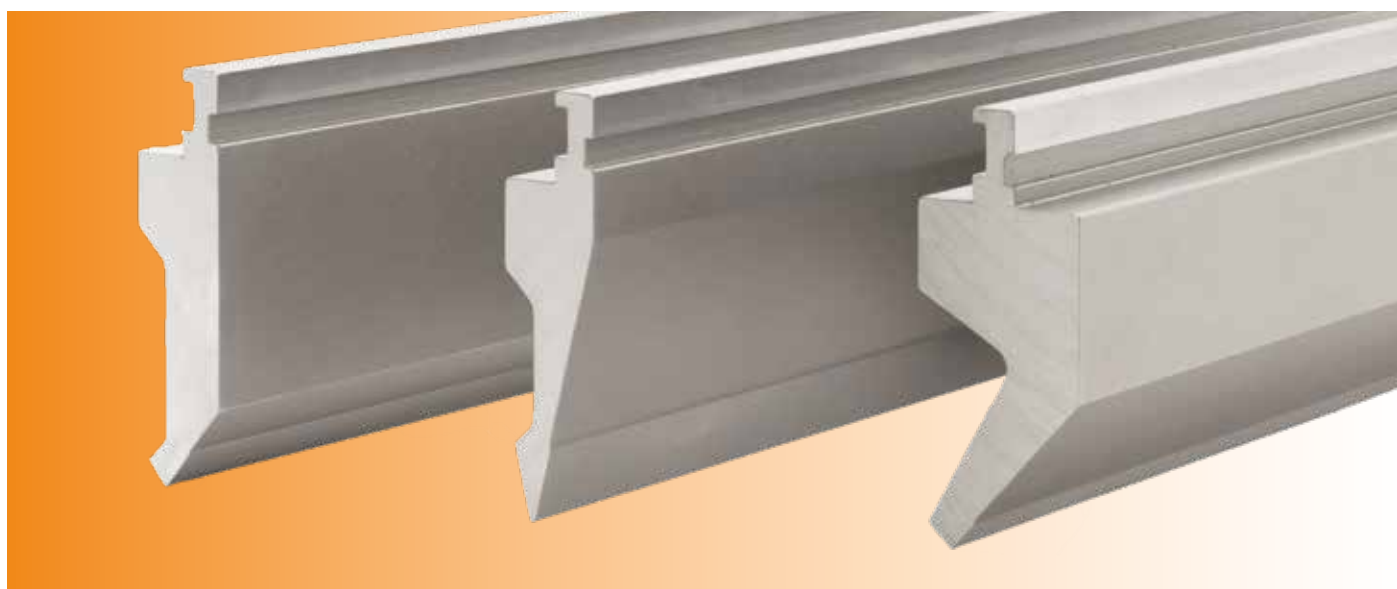

PUNZONI / PUNCHES *BYSTRONIC - BEYELER RF-A STYLE*

I PUNZONI STANDARD SONO DISPONIBILI A MAGAZZINO NELLE LUNGHEZZE DI: 100 / 200 / 300 mm - 515 mm E FRAZIONATI (550 mm)
 THE PUNCHES ARE AVAILABLE IN THE FOLLOWING STANDARD LENGTHS: 100 / 200 / 300 mm - 515 mm AND SECTIONED (550 mm)

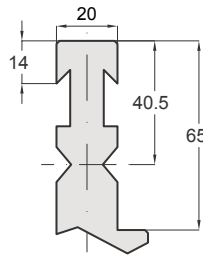
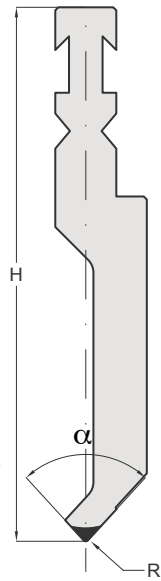

BEYELER FR-A

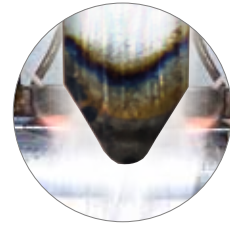

TEMPRA AD INDUZIONE 52-55 HRC
 INDUCTION HARDENED 52-55 HRC

LEGENDA	α = ANGOLO	R = RAGGIO	H = ALTEZZA
LEGEND	α = ANGLE	R = RADIUS	H = HEIGHT

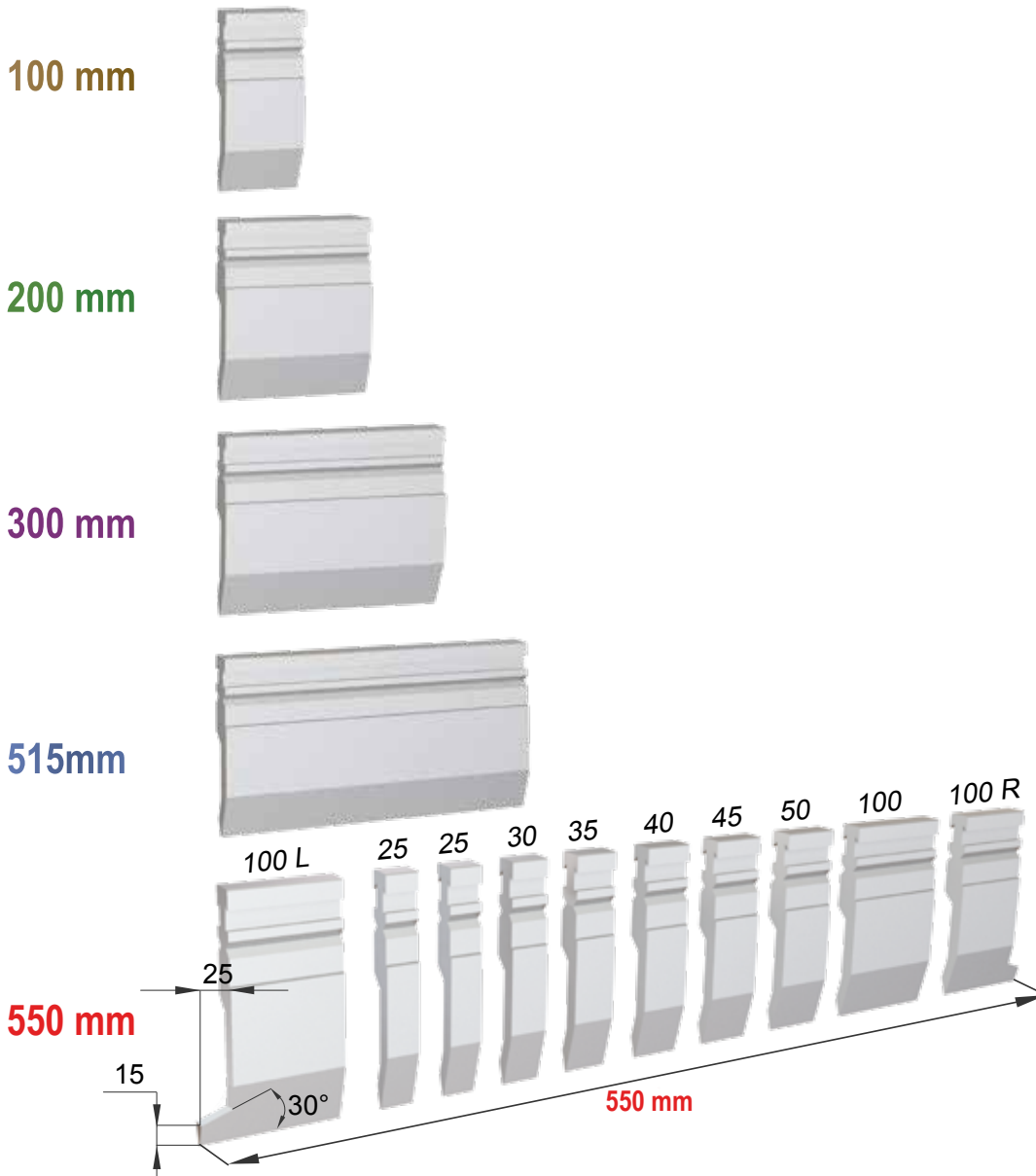

IL CARICO MASSIMO DELLE SCARPETTE CORRISPONDE AL 50% DEL CARICO MASSIMO INDICATO SUL PUNZONE.
 THE MAX LOAD OF THE HORN EXTENSIONS IS 50% OF THE MAX LOAD OF THE PUNCH.

CODE	α	R	H	T/Mt	Mt
14.150	85°	1.00	175.00	130	■

100 mm
200 mm
300 mm
515 mm
550 mm SECTIONED

CODE	α	R	H	T/Mt	Mt
14.151	85°	1.00	175.00	130	■

100 mm
200 mm
300 mm
515 mm
550 mm SECTIONED

CODE	α	R	H	T/Mt	Mt
14.152	85°	1.50	175.00	90	■

100 mm
200 mm
300 mm
515 mm
550 mm SECTIONED

CODE	α	R	H	T/Mt	Mt
14.153	30°	1.00	175.00	100	■

100 mm
200 mm
300 mm
515 mm
550 mm SECTIONED

CODE	α	R	H	T/Mt	Mt
14.154	30°	1.00	175.00	150	■

100 mm
200 mm
300 mm
515 mm
550 mm SECTIONED

CODE	α	R	H	T/Mt	Mt
14.155	30°	3.00	175.00	160	■

100 mm
200 mm
300 mm
515 mm
550 mm SECTIONED

CODE	α	R	H	T/Mt	Mt
14.156	85°	1.00	175.00	100	■

100 mm
200 mm
300 mm
515 mm
550 mm SECTIONED

CODE	α	R	H	T/Mt	Mt
14.157	60°	4.00	175.00	160	■

100 mm
200 mm
300 mm
515 mm
550 mm SECTIONED



CODE	α	R	H	T/Mt	Mt
14.158	85°	1.00	250.00	100	■

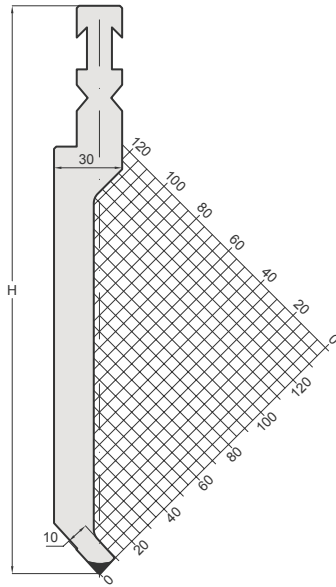

- 100 mm
- 200 mm
- 300 mm
- 515 mm
- 550 mm SECTIONED

CODE	α	R	H	T/Mt	Mt
14.159	85°	1.00	250.00	140	■

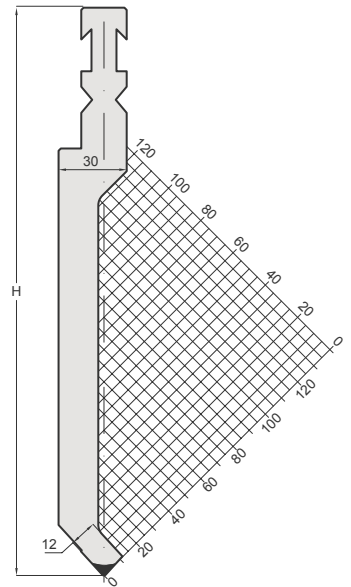

- 100 mm
- 200 mm
- 300 mm
- 515 mm
- 550 mm SECTIONED

CODE	α	R	H	T/Mt	Mt
14.160	85°	1.50	250.00	60	■

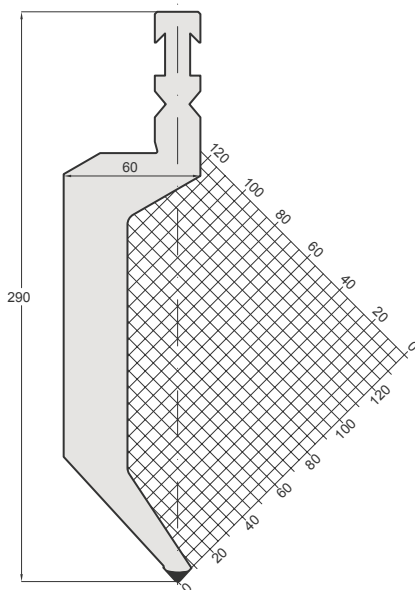

- 100 mm
- 200 mm
- 300 mm
- 515 mm
- 550 mm SECTIONED

CODE	α	R	H	T/Mt	Mt
14.165	60°	4.00	250.00	160	■

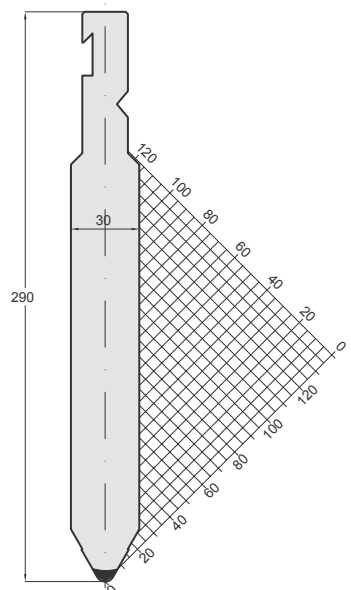

- 100 mm
- 200 mm
- 300 mm
- 515 mm
- 550 mm SECTIONED

CODE	α	R	H	T/Mt	Mt
14.161	30°	1.00	250.00	75	■

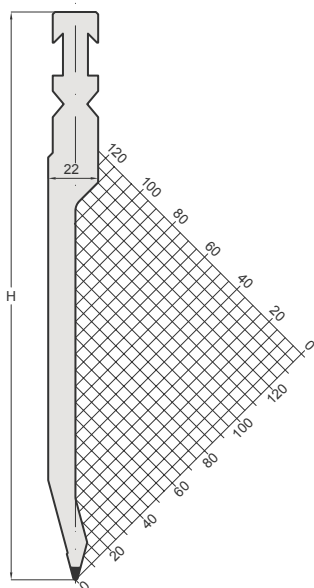

100 mm
200 mm
300 mm
515 mm
550 mm
SECTIONED

CODE	α	R	H	T/Mt	Mt
14.162	30°	1.00	250.00	140	■

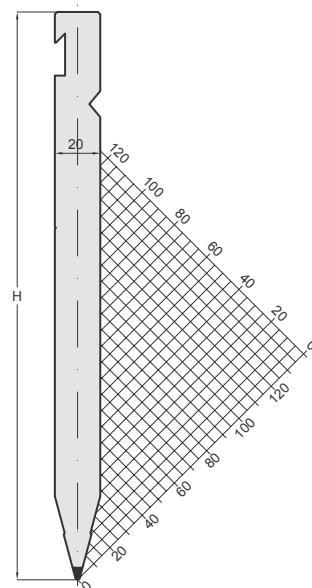

100 mm
200 mm
300 mm
515 mm
550 mm
SECTIONED

CODE	α	R	H	T/Mt	Mt
14.163	30°	3.00	250.00	140	■

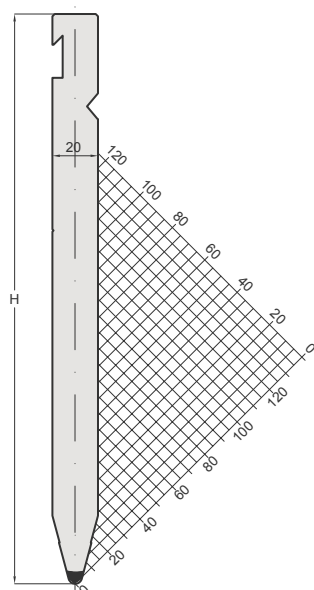

100 mm
200 mm
300 mm
515 mm
550 mm
SECTIONED

CODE	α	R	H	T/Mt	Mt
14.164	85°	1.00	250.00	100	■

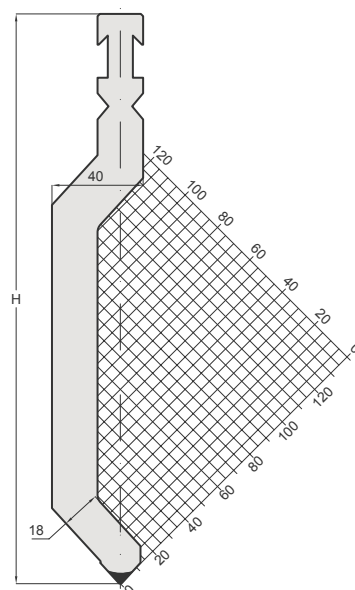

100 mm
200 mm
300 mm
515 mm
550 mm
SECTIONED

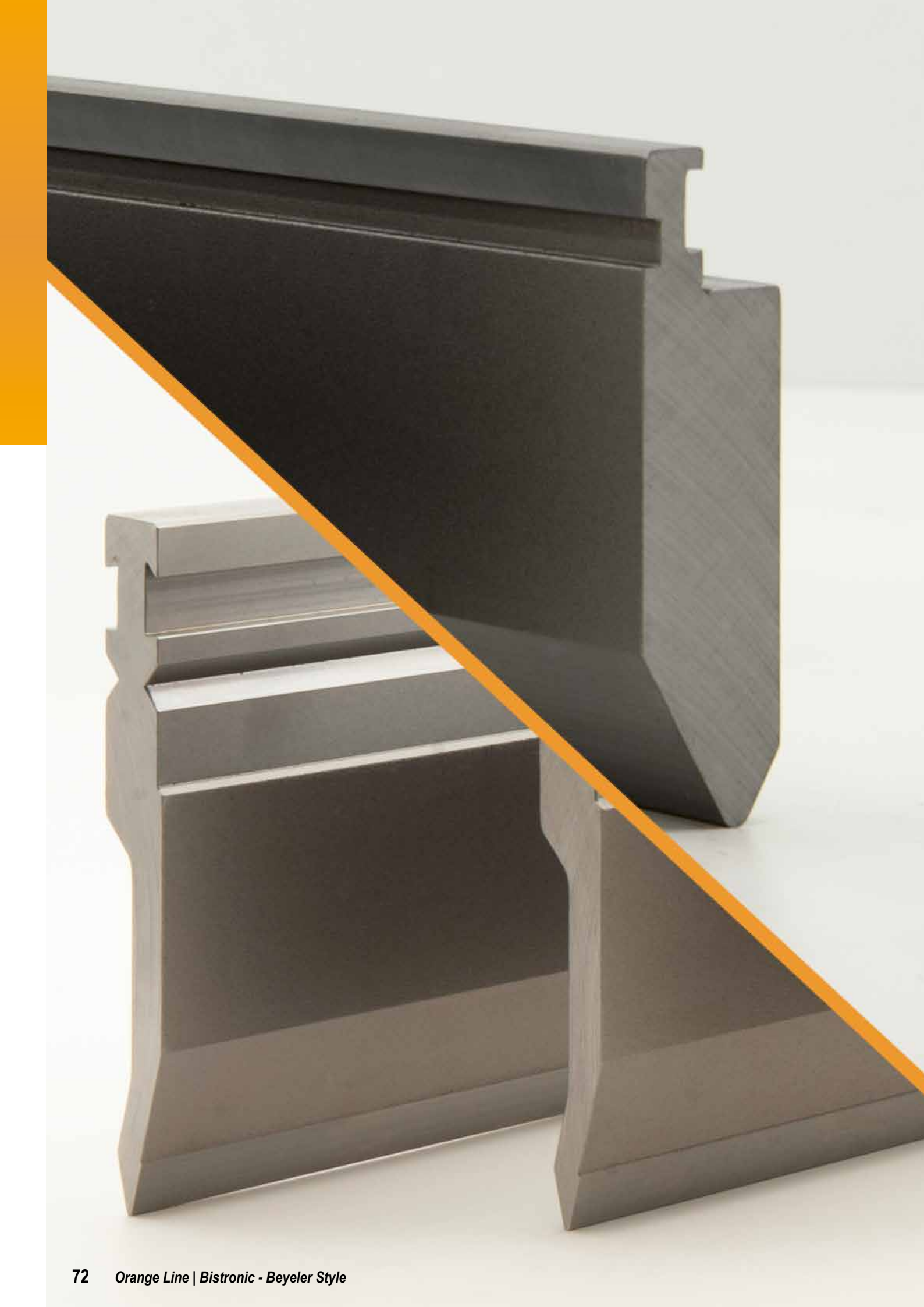

BYSTRONIC - BEYELER STYLE

MATRICI

DIES

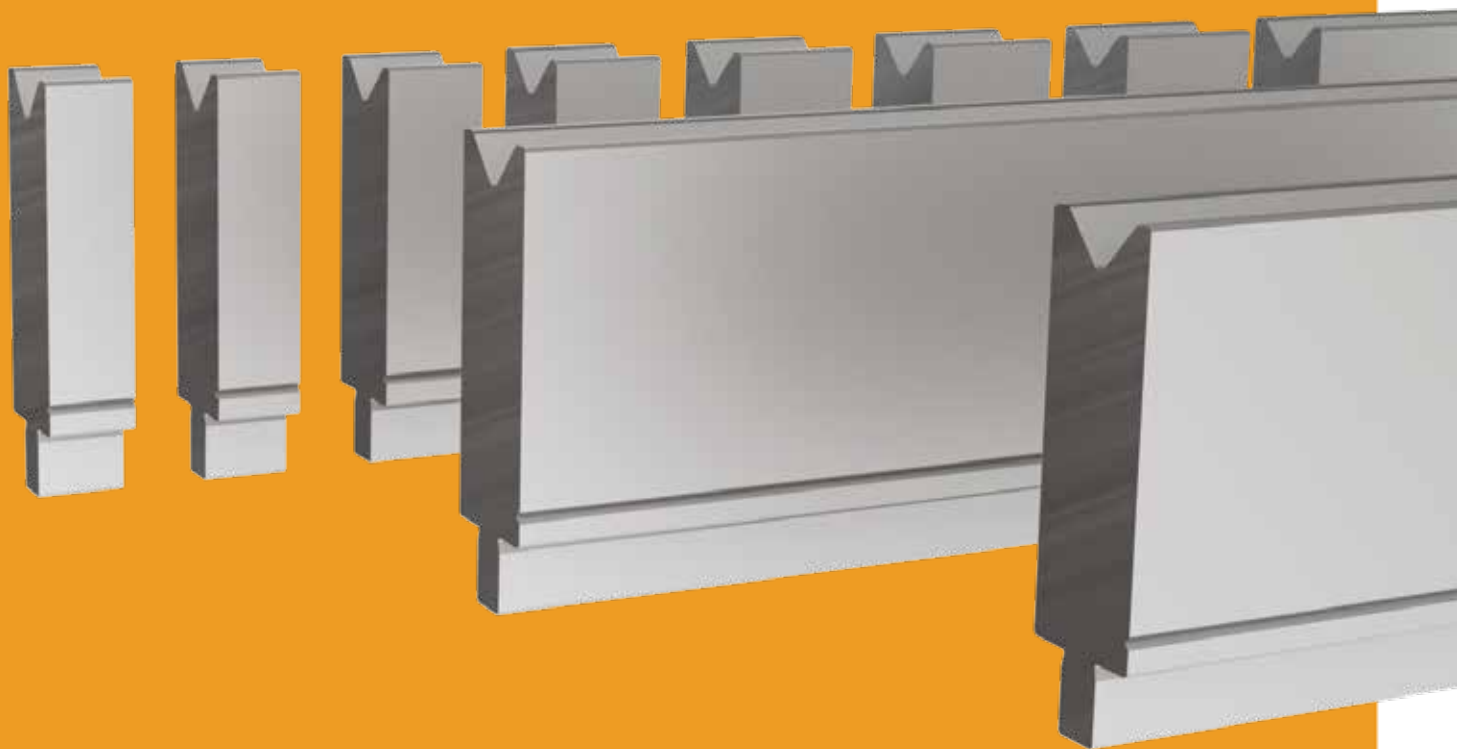

ORANGE LINE

BYSTRONIC - BEYELER STYLE



MATRICI / DIES *BYSTRONIC - BEYELER STYLE*

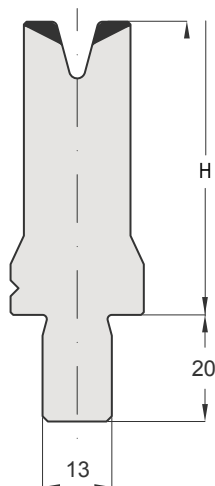
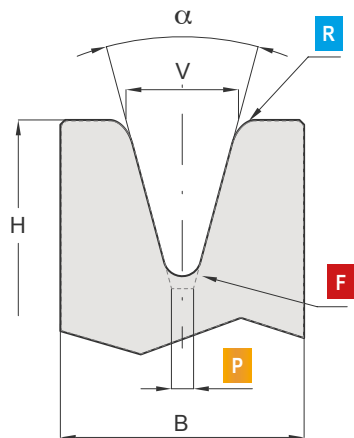

TEMPRA AD INDUZIONE 52-55 HRC
INDUCTION HARDENED 52-55 HRC

100 mm | 200 mm | 300 mm | 515 mm | 550 mm SECTIONED

LE MATRICI STANDARD SONO DISPONIBILI A MAGAZZINO NELLE LUNGHEZZE DI: 100 / 200 / 300 mm - 515 mm E FRAZIONATI (550 mm)
THE DIES ARE AVAILABLE IN THE FOLLOWING STANDARD LENGTHS: 100 / 200 / 300 mm - 515 mm AND SECTIONED (550 mm)

LEGENDA	α = ANGOLO	V = AMPIEZZA CAVA	R = RAGGIO	H = ALTEZZA	F= FONDO MATRICE	P= PIANO	B= BASE
LEGEND	α = ANGLE	V = DIE OPENING	R = RADIUS	H = HEIGHT	F= BOTTOM DIES	P= FLAT	B= WIDTH

CODE	α	V	R	H	B	T	F	T/mt	Mt
24.080	80°	80	10.00	65	100	100	P15.0	140	■
24.180	80°	100	12.00	85	125	125	P15.0	180	■
24.120	80°	120	15.00	105	160	160	P35.0	200	■
24.040	60°	40	5.00	55	55	55	R5.0	80	■
24.050	60°	50	5.00	55	70	70	P15.0	100	■
24.060	60°	60	7.00	65	80	80	P15.0	100	■
24.306	30°	6	0.75	55	20	25	R0.7	40	■
24.308	30°	8	1.00	55	20	25	R1.5	30	■
24.310	30°	10	1.00	55	20	25	R1.5	20	■
24.312	30°	12	1.50	55	25	25	R1.5	25	■
24.017	30°	16	2.00	55	30	30	P5.0	45	■
24.320	30°	20	2.50	55	30	30	P4.0	15	■
24.018	30°	24	2.00	55	40	40	P8.0	50	■
24.332	30°	32	4.00	55	55	55	P14.0	30	■

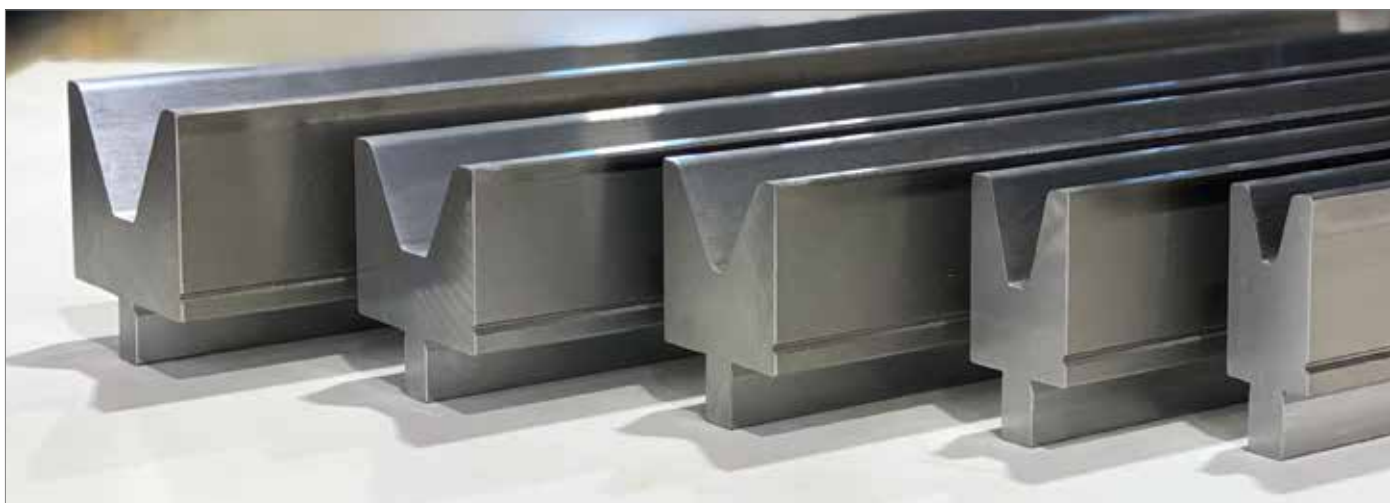

BYSTRONIC - BEYELER STYLE

PIEGASCHIACCIA

HEMMING TOOLS

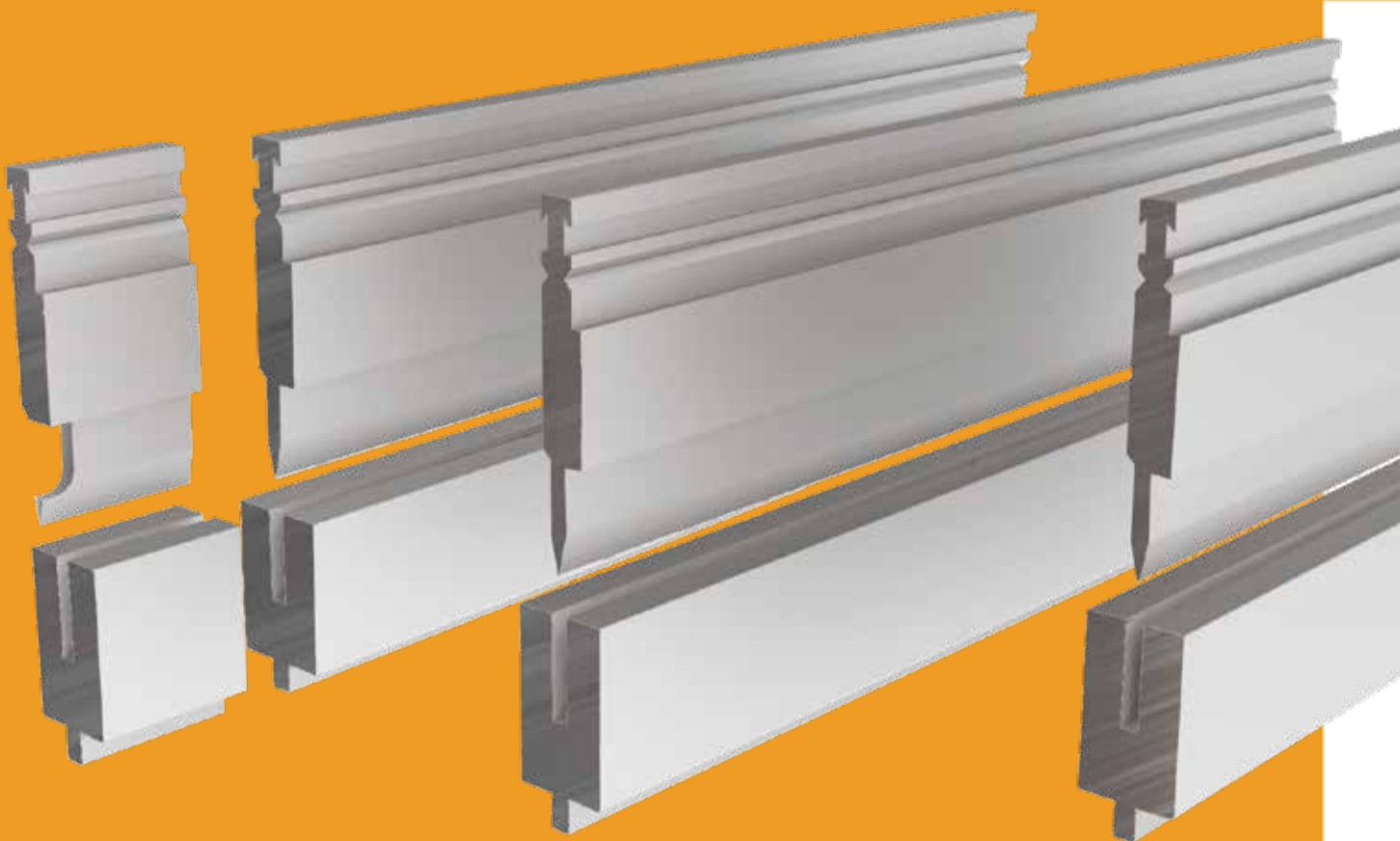

ORANGE LINE

BYSTRONIC - BEYELER STYLE

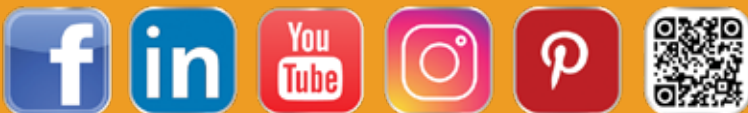

PIEGASCHIACCIA / HEMMING TOOLS *BYSTRONIC - BEYELER STYLE*

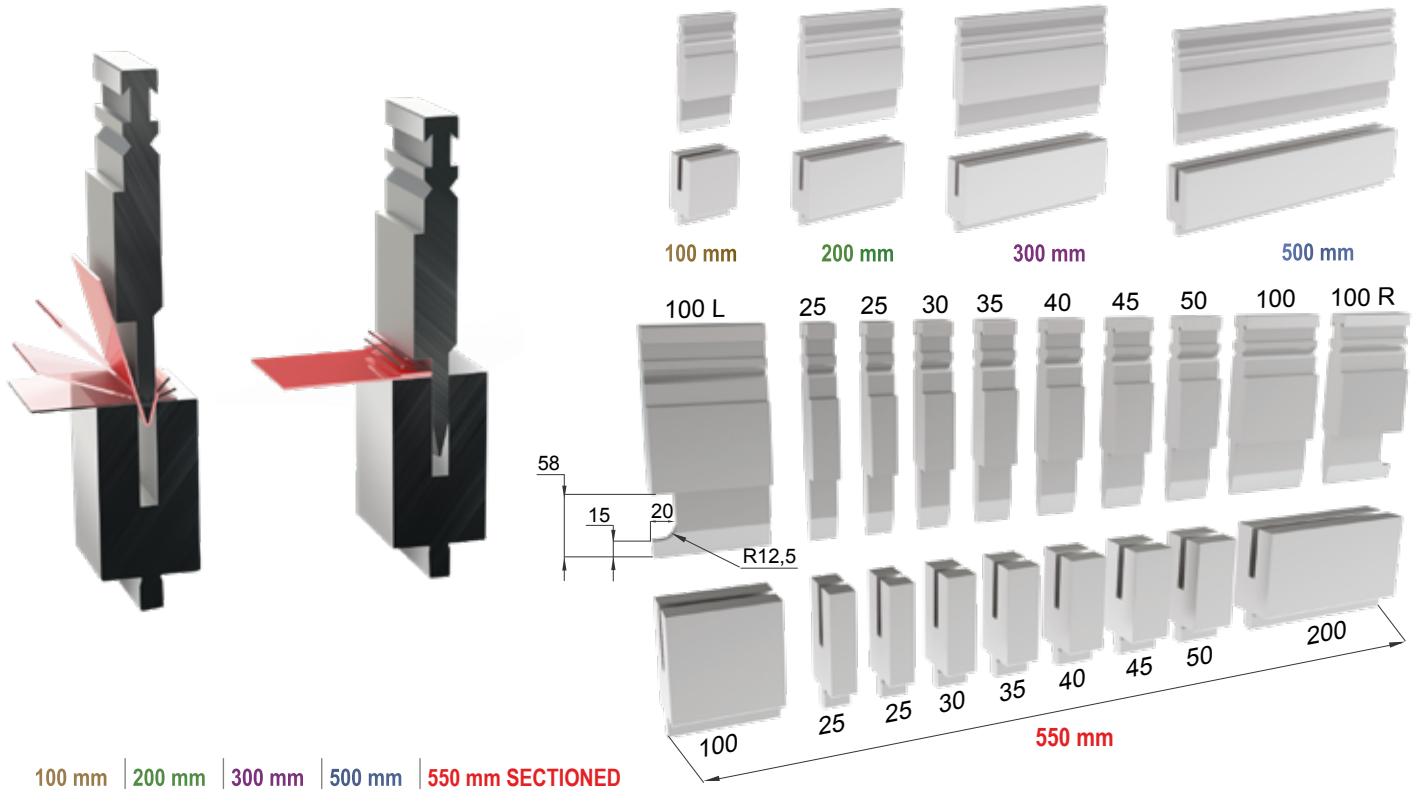

100 mm | 200 mm | 300 mm | 500 mm | 550 mm SECTIONED

IL CARICO MASSIMO DELLE SCARPETTE CORRISPONDE AL 50% DEL CARICO MASSIMO INDICATO SUL PUNZONE.
 THE MAX LOAD OF THE HORN EXTENSIONS IS 50% OF THE MAX LOAD OF THE PUNCH.

MATERIAL ACC.R ~ 40 Kg/MM ²					MATERIAL ACC.R ~ 70 Kg/MM ²				
S (mm)	(t/m)	T (mm)	(t/m)	2S(mm)	S (mm)	(t/m)	T (mm)	(t/m)	2S(mm)
0,6	9	3	23	1,2	0,6	15	3	35	1,2
0,8	12	3	32	1,6	0,8	20	3	50	1,6
1,0	15	3,5	40	2,0	1,0	25	3,5	60	2,0
1,25	17	3,5	50	2,5	1,25	26	3,5	80	2,5
1,5	22	4,6	63	3,0	1,5	38	4,6	95	3,0
2,0	30	5,5	80	4,0	2,0	50	5,5	130	4,0
2,5	55	6,5	90	5,0					
3,0	70	8,0	100	6,0					



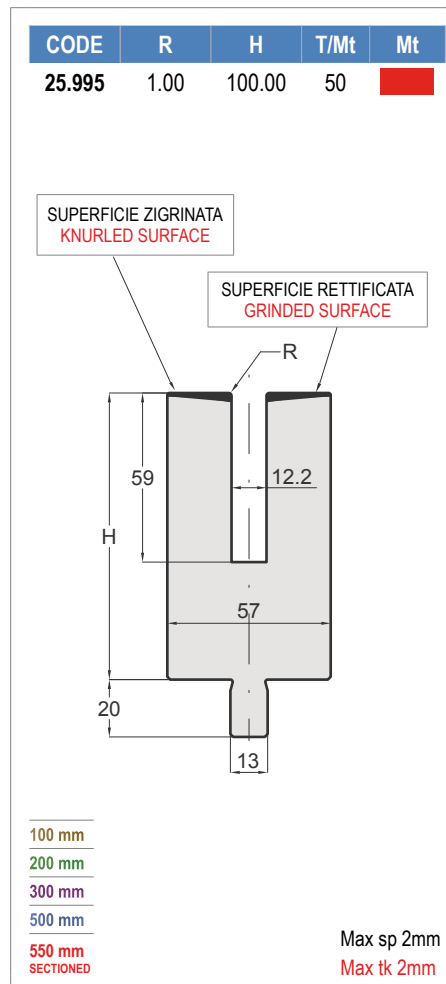
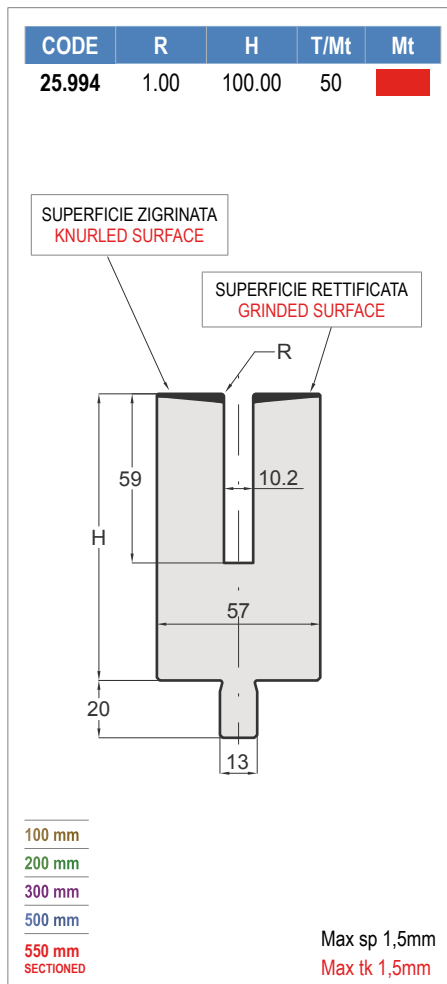
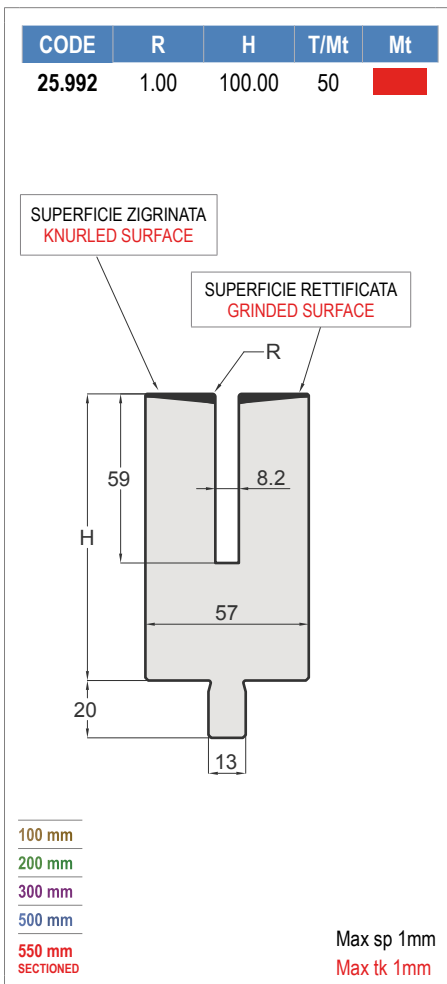
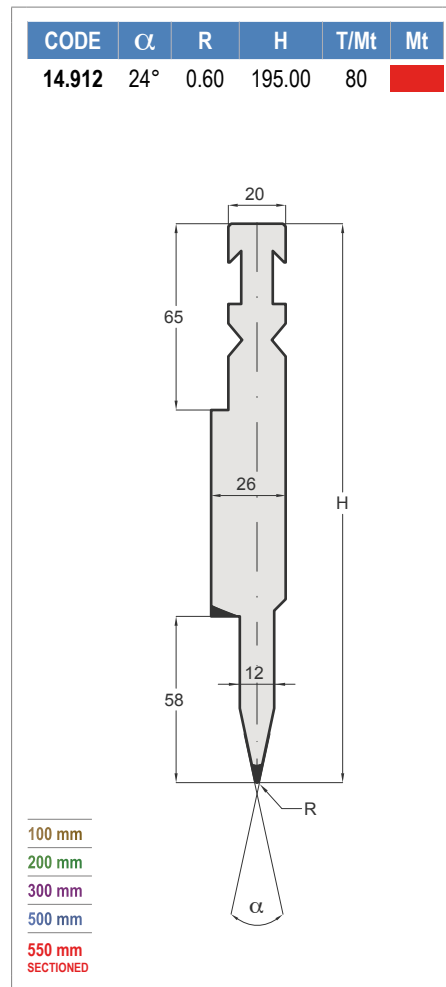
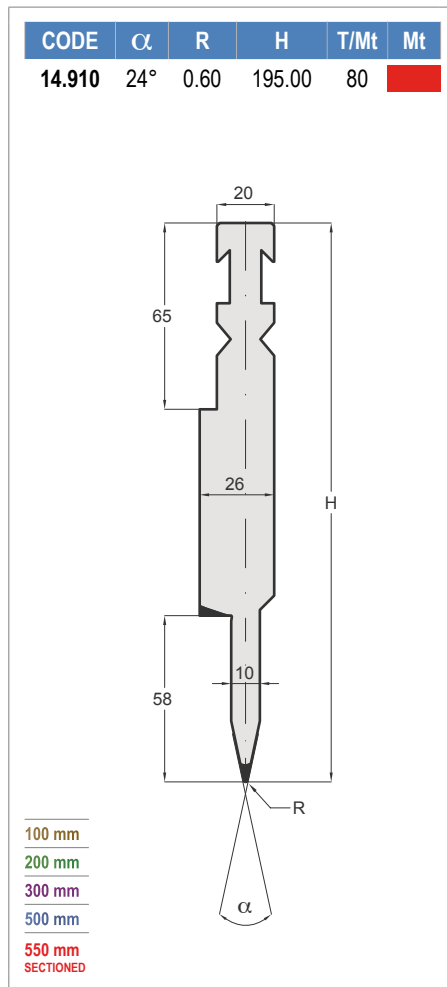
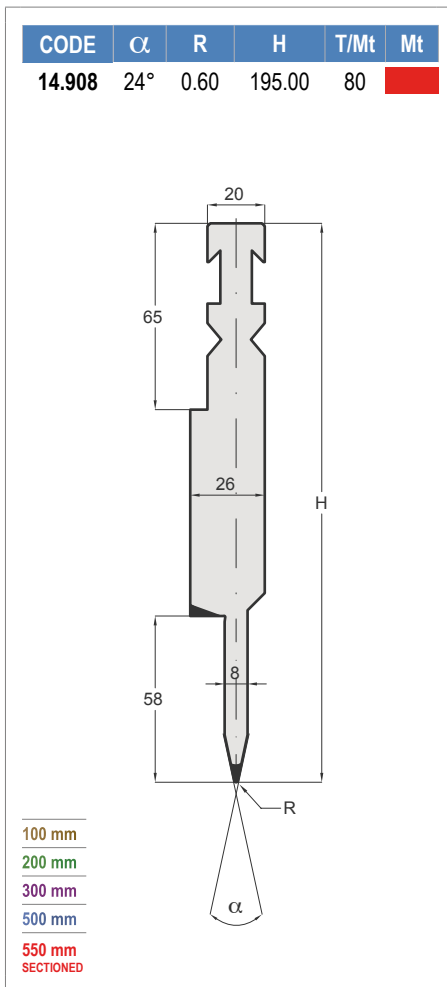



LVD STYLE

PUNZONI

PUNCHES



BLACK LINE

LVD STYLE



PUNZONI / PUNCHES LVD STYLE

I PUNZONI STANDARD SONO DISPONIBILI A MAGAZZINO NELLE LUNGHEZZE DI: 510 mm E FRAZIONATI (550 mm)
 THE PUNCHES ARE AVAILABLE IN THE FOLLOWING STANDARD LENGTHS: 510 mm AND SECTIONED (550 mm)

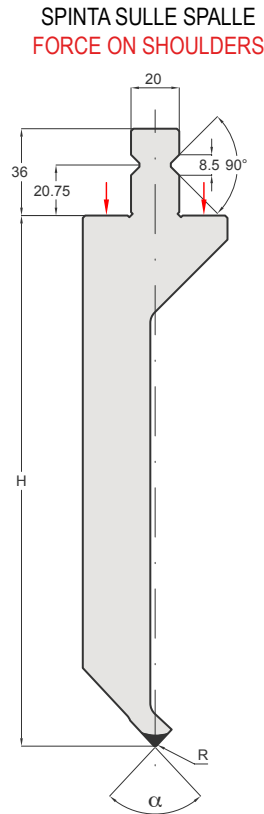
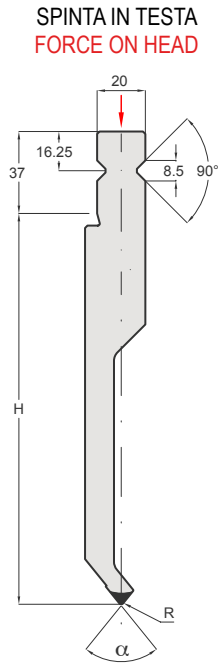

TEMPRA AD INDUZIONE 52-55 HRC
INDUCTION HARDENED 52-55 HRC

LEGENDA	α = ANGOLO	R = RAGGIO	H = ALTEZZA
LEGEND	α = ANGLE	R = RADIUS	H = HEIGHT

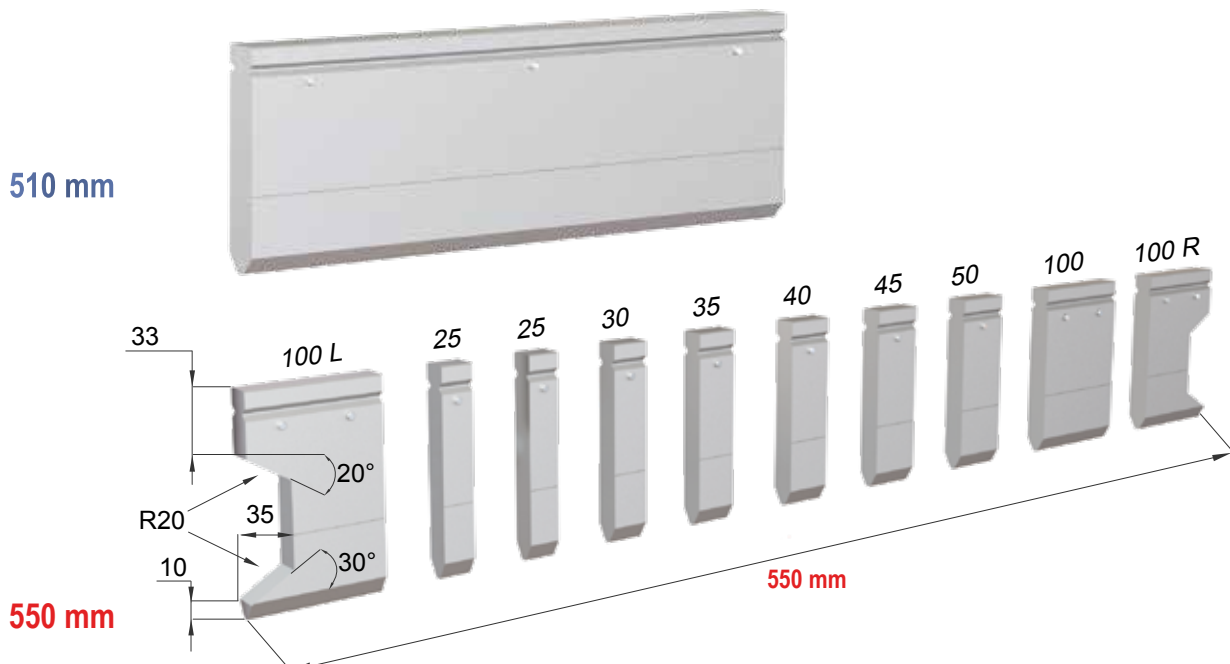
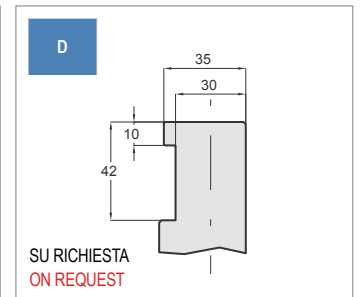
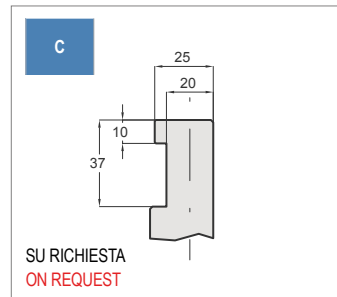
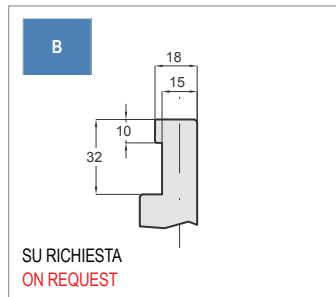
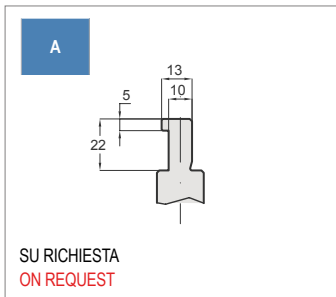

IL CARICO MASSIMO DELLE SCARPETTE CORRISPONDE AL 50% DEL CARICO MASSIMO INDICATO SUL PUNZONE.
 THE MAX LOAD OF THE HORN EXTENSIONS IS 50% OF THE MAX LOAD OF THE PUNCH.

PUNZONI / PUNCHES LVD STYLE 26° / 78°

MONTAGGIO E SMONTAGGIO LATERALE DEGLI UTENSILI
SIDE INSTALLATION AND DISINSTALLATION OF TOOLS

SPINTA IN TESTA
FORCE ON HEAD



SPINTA SULLE SPALLE
FORCE ON SHOULDERS

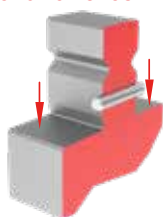

CODE

70.130



SPARE PARTS

MONTAGGIO E SMONTAGGIO FRONTALE DEGLI UTENSILI
FRONT INSTALLATION AND DISINSTALLATION OF TOOLS

SPINTA IN TESTA
FORCE ON HEAD



SPINTA SULLE SPALLE
FORCE ON SHOULDERS

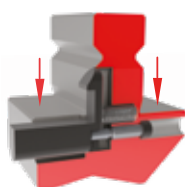

SOLO PER STAMPI FINO ≤ 12,5 KG
ONLY FOR TOOLS ≤ 12,5 KG

70.714



16.204 16.209

70.715



16.201 16.202 16.203
16.206 16.207 16.208

70.718



16.200 16.205

CODE	α	R	H	T/Mt	Mt
16.200	78°	1.00	159.00	40	

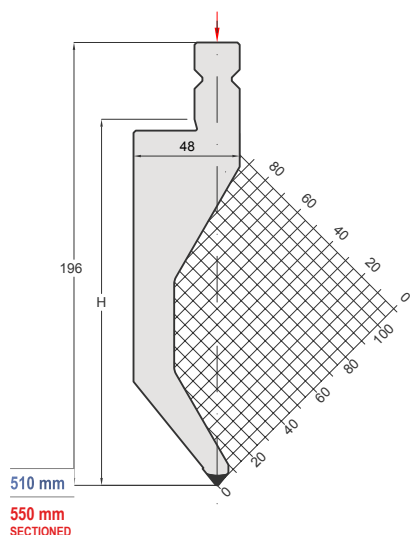

CODE	α	R	H	T/Mt	Mt
16.201	78°	1.00	159.00	40	

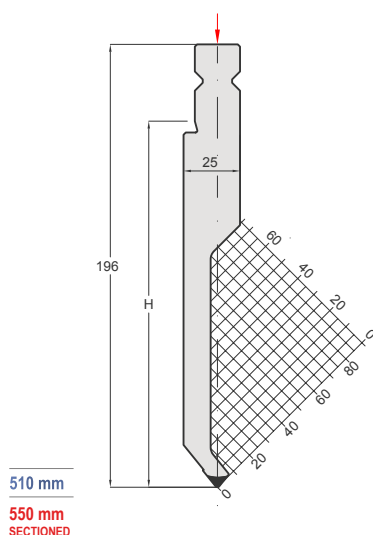

CODE	α	R	H	T/Mt	Mt
16.202	26°	1.00	159.00	40	

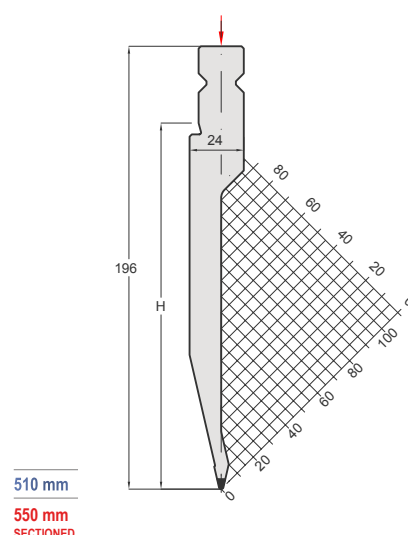

PUNZONI / PUNCHES LVD STYLE 26° / 78°

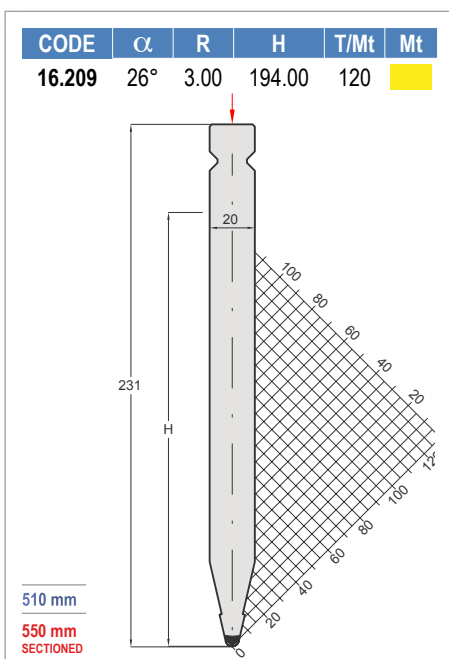
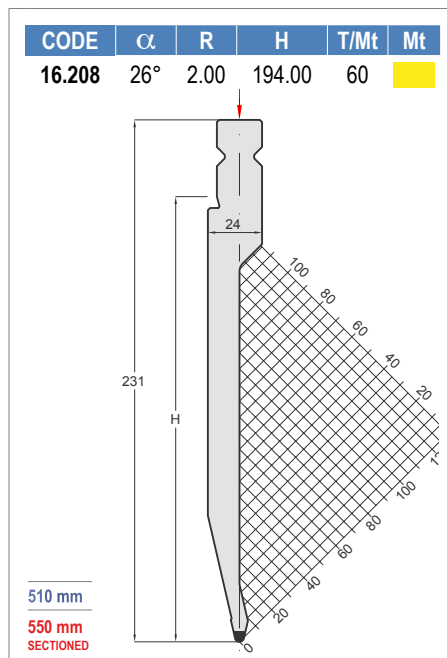
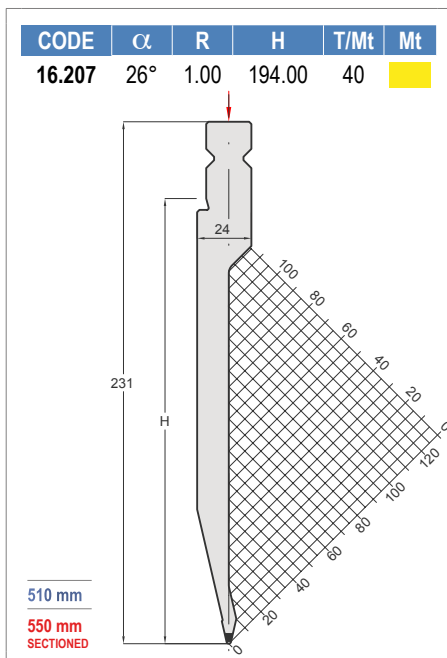
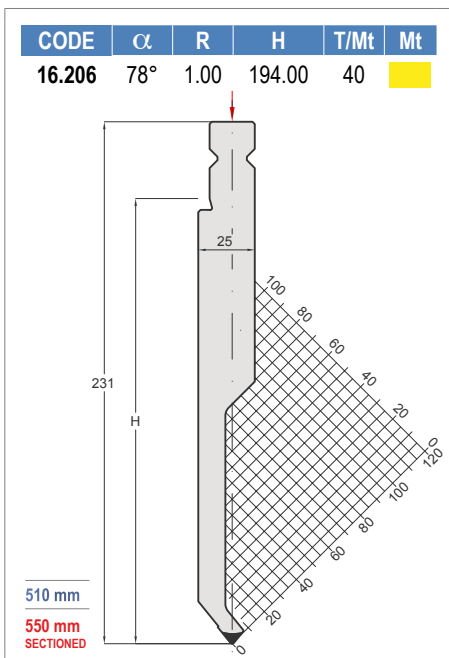
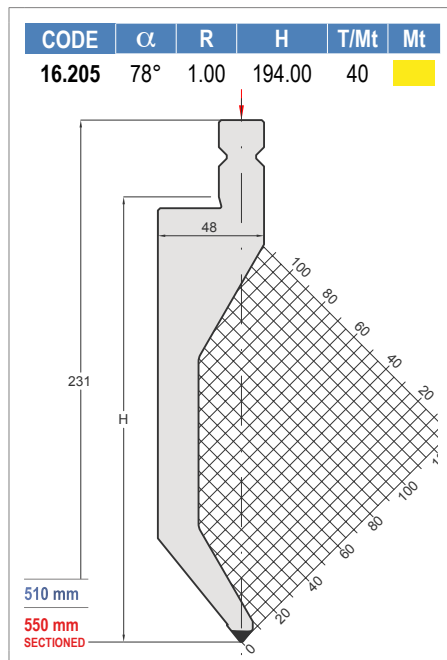
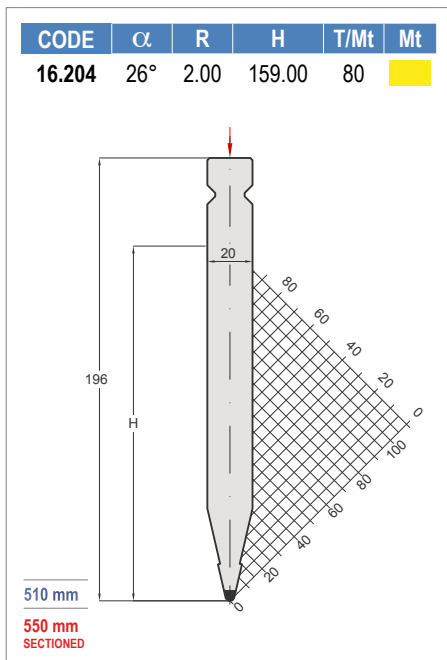
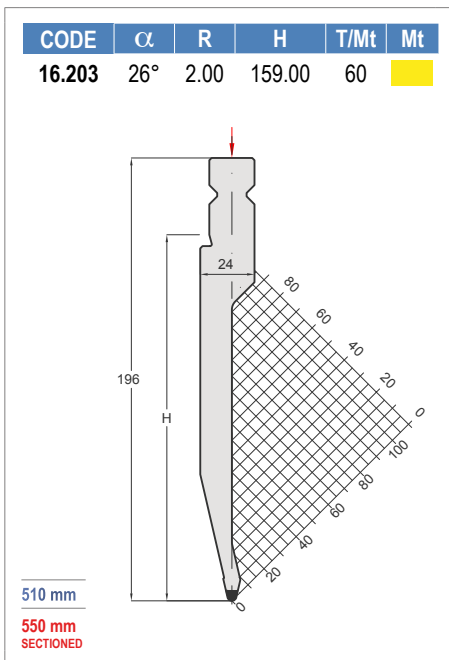

LVD STYLE

MATRICI

DIES

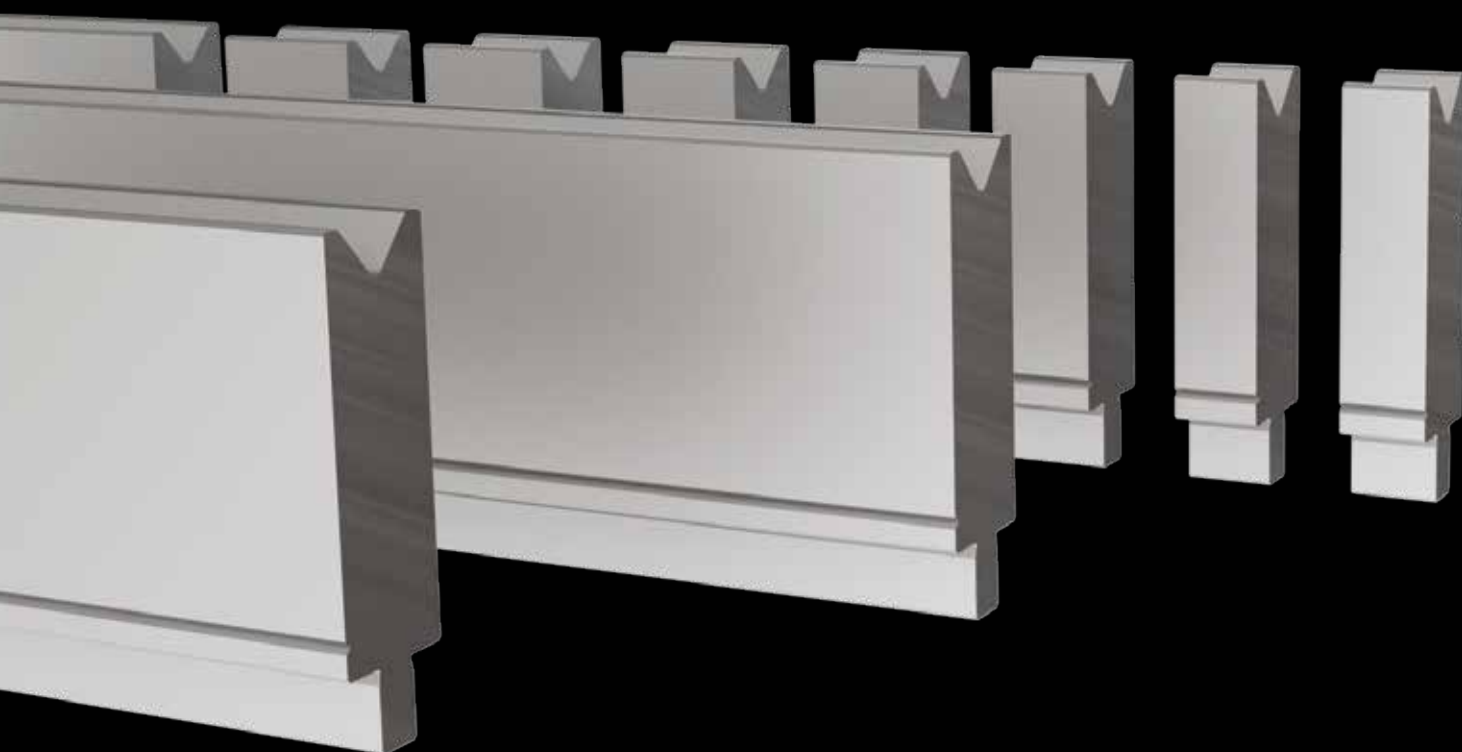

BLACK LINE

LVD STYLE



MATRICI / DIES LVD STYLE

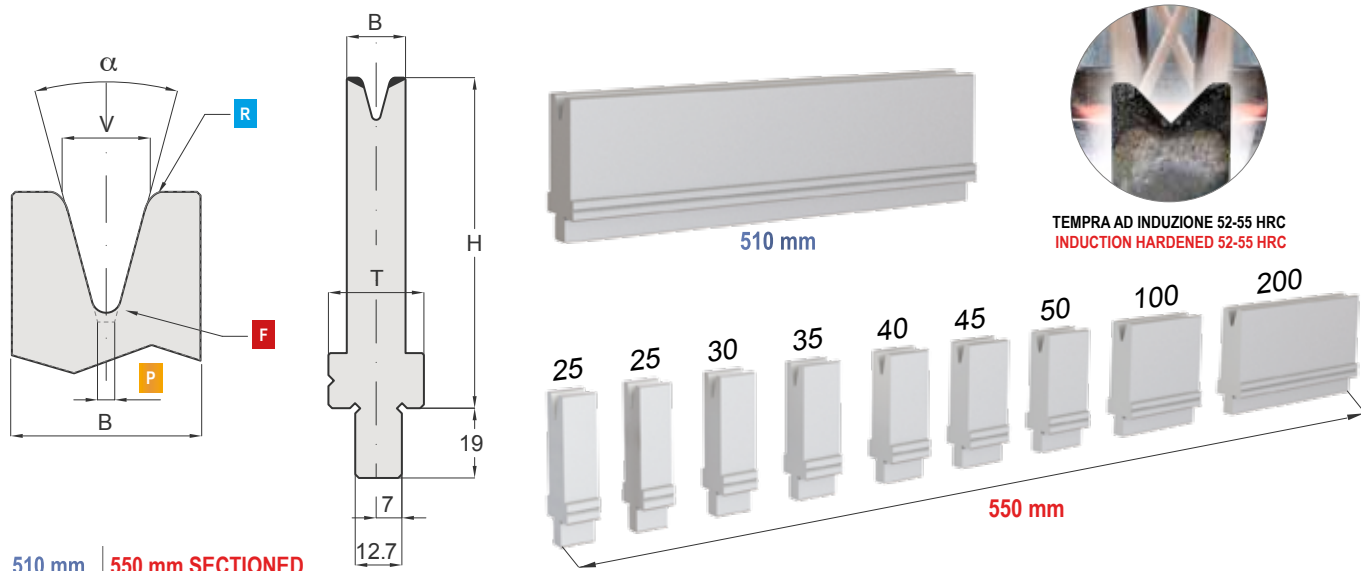

510 mm | 550 mm SECTIONED

LE MATRICI STANDARD SONO DISPONIBILI A MAGAZZINO NELLE LUNGHEZZE DI: 510 mm E FRAZIONATI (550 mm)
 THE DIES ARE AVAILABLE IN THE FOLLOWING STANDARD LENGTHS: 510 mm AND SECTIONED (550 mm)

LEGENDA	α = ANGOLO	V = AMPIEZZA CAVA	R = RAGGIO	H = ALTEZZA	F= FONDO MATRICE	P= PIANO	B= BASE
LEGEND	α = ANGLE	V = DIE OPENING	R = RADIUS	H = HEIGHT	F= BOTTOM DIES	P= FLAT	B= WIDTH

CODE	α	V	B	T	R	H	F	T/mt	Mt	CODE	α	V	B	T	R	H	F	T/mt	Mt
26.200	30°	6	14	26	0.80	90	R1.0	25	■	26.251	30°	8	16	26	0.80	130	R1.2	26	■
26.201	30°	8	16	26	0.80	90	R1.2	26	■	26.252	30°	10	22	26	1.00	130	R1.5	36	■
26.202	30°	10	22	26	1.00	90	R1.5	36	■	26.253	30°	12	26	26	1.20	130	R2.0	46	■
26.203	30°	12	26	26	1.20	90	R2.0	46	■	26.254	30°	16	30	30	1.60	130	R2.5	51	■
26.204	30°	16	30	30	1.60	90	R2.5	51	■	26.255	30°	20	40	40	2.00	130	R3.0	68	■
26.205	30°	20	40	40	2.00	90	R3.0	68	■	26.256	30°	24	46	46	2.40	130	R5.0	93	■
26.206	30°	24	46	46	2.40	90	R5.0	93	■	26.257	30°	30	56	56	3.00	130	R5.0	110	■
26.207	30°	30	56	56	3.00	90	R5.0	110	■	26.258	30°	40	75	75	4.00	130	R7.0	140	■
26.208	30°	40	75	75	4.00	90	R7.0	140	■	26.259	30°	50	90	90	4.00	130	R10	170	■
26.209	30°	50	90	90	4.00	90	R10	135	■	26.260	30°	60	95	95	5.00	130	R13	140	■
26.211	78°	6	10	26	0.80	90	R0.8	28	■	26.262	78°	6	10	26	0.80	130	R0.8	28	■
26.212	78°	8	12	26	0.80	90	R1.2	32	■	26.263	78°	8	12	26	0.80	130	R1.2	32	■
26.213	78°	10	14	26	1.00	90	R1.5	36	■	26.264	78°	10	14	26	1.00	130	R1.5	36	■
26.214	78°	12	18	26	1.20	90	R2.0	50	■	26.265	78°	12	18	26	1.20	130	R2.0	50	■
26.215	78°	16	25	25	1.60	90	R2.5	70	■	26.266	78°	16	25	25	1.60	130	R2.5	70	■
26.216	78°	20	30	30	2.00	90	R3.0	75	■	26.267	78°	20	30	30	2.00	130	R3.0	75	■
26.217	78°	24	32	32	2.40	90	R4.0	91	■	26.268	78°	24	32	32	2.40	130	R4.0	91	■
26.218	78°	30	40	40	3.00	90	R5.0	115	■	26.269	78°	30	40	40	3.00	130	R5.0	115	■
26.219	78°	40	50	50	4.00	90	R8.0	135	■	26.270	78°	40	50	50	4.00	130	R8.0	135	■
26.220	78°	50	65	65	4.00	90	R10	180	■	26.271	78°	50	65	65	4.00	130	R10	180	■
26.221	78°	60	75	75	5.00	90	R12	200	■	26.272	78°	60	75	75	5.00	130	R12	200	■
26.222	78°	80	95	95	6.00	90	R16	230	■	26.273	78°	80	95	95	6.00	130	R16	230	■
26.223	78°	100	125	125	6.00	90	R20	250	■	26.274	78°	100	125	125	6.00	130	R20	250	■
26.250	30°	6	14	26	0.80	130	R1.0	28	■	26.275	78°	120	140	140	6.00	130	R25	340	■



AJIAL - AMERICAN - COLGAR
COLLY - HÄMMERLE - EHT
NEWTON - WEINBRENNER STYLE

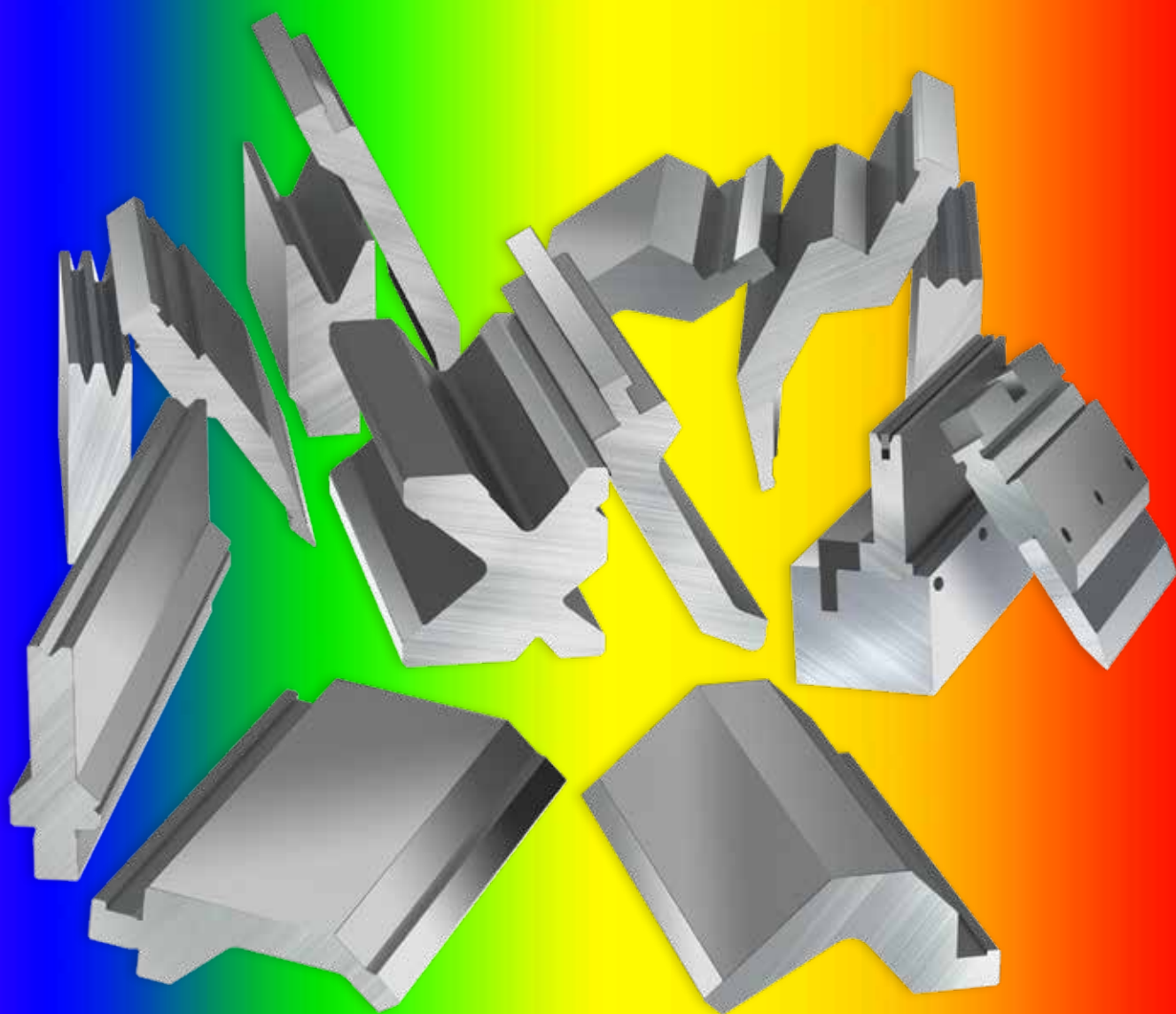

RAINBOW LINE

UTENSILI MULTIMARCA
MULTI BRAND TOOLS



PUNZONI / PUNCHES AJIAL STYLE

I PUNZONI SONO PRODOTTI A RICHIESTA NELLE LUNGHEZZE DI: 1020 mm E FRAZIONATI (990 mm)
 THE PUNCHES ARE PRODUCED ON REQUEST IN THE FOLLOWING LENGTHS: 1020 mm AND SECTIONED (990 mm)

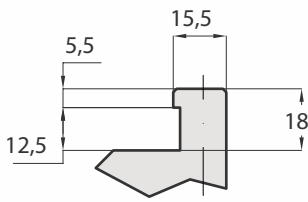

CODE
 H =
 B =
 R =
 α =

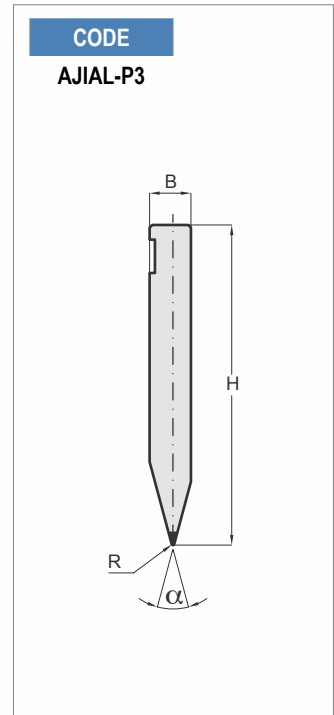
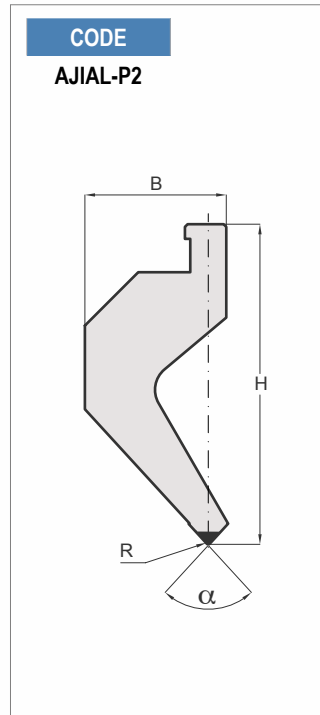
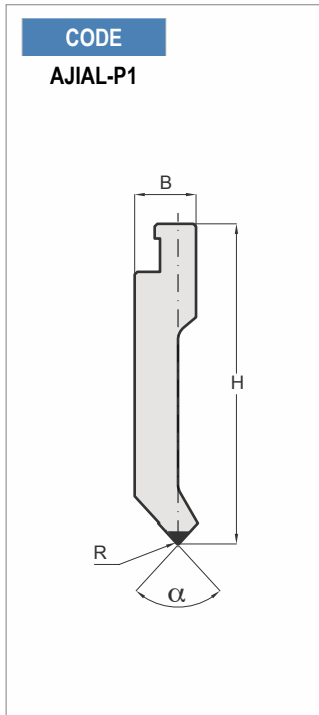

1020 mm | 990 mm SECTIONED

SPECIFICARE DIMENSIONI / SPECIFY DIMENSIONS

MATRICI / DIES AJIAL STYLE

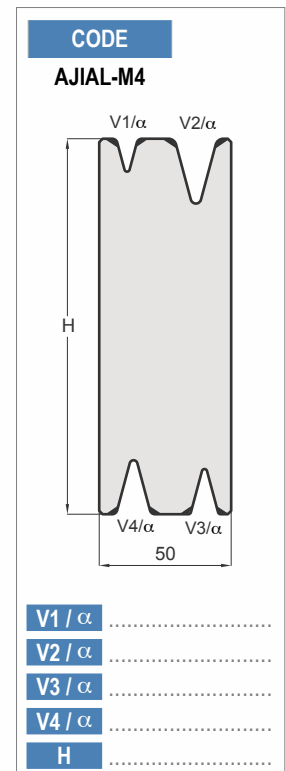
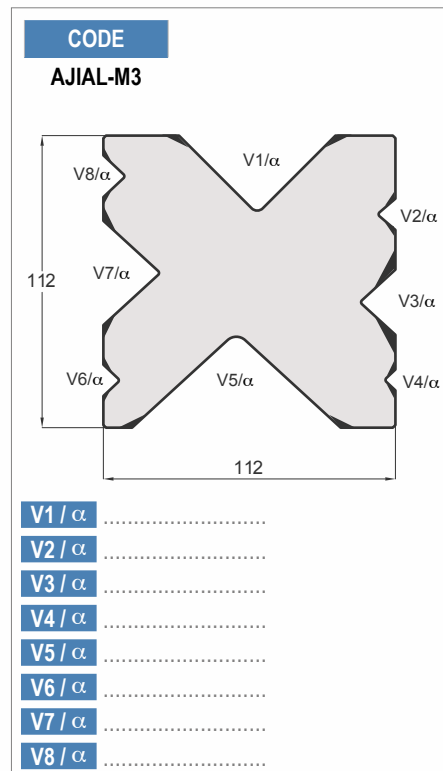
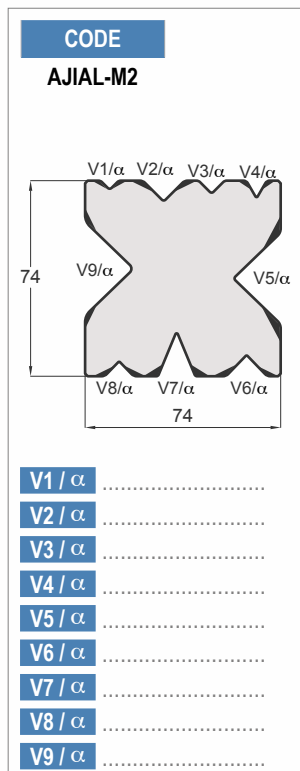
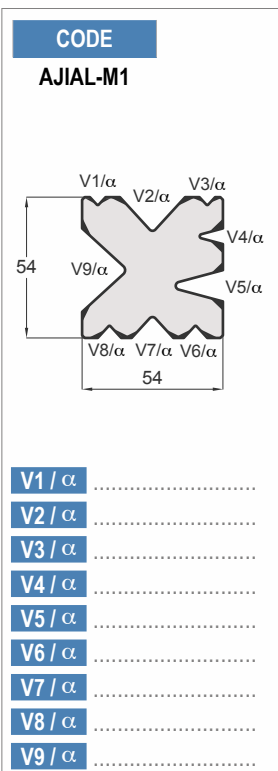

1020 mm | 990 mm SECTIONED

SPECIFICARE DIMENSIONI / SPECIFY DIMENSIONS

PUNZONI / PUNCHES MATRICI / DIES AMERICAN STYLE

PUNZONI A RICHIESTA NELLE LUNGHEZZE DI: 18" (457.2 mm)
 PUNCHES ON REQUEST IN THE FOLLOWING LENGTHS: 18" (457.2 mm)

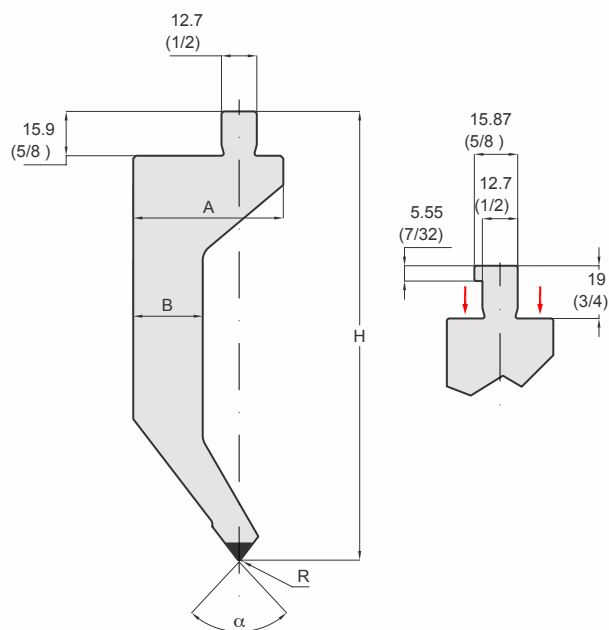

457.2 mm | 18" inches

LEGENDA	α = ANGOLO	R = RAGGIO	H = ALTEZZA
LEGEND	α = ANGLE	R = RADIUS	H = HEIGHT

MATRICI A RICHIESTA NELLE LUNGHEZZE DI: 18" (457.2 mm)
 DIES ON REQUEST IN THE FOLLOWING LENGTHS: 18" (457.2 mm)

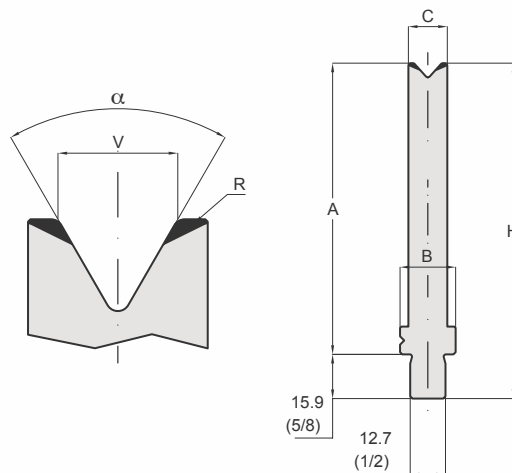

457.2 mm | 18" inches

LEGENDA	α = ANGOLO	R = RAGGIO	H = ALTEZZA
LEGEND	α = ANGLE	R = RADIUS	H = HEIGHT

ADATTATORI / ADAPTERS AMERICAN STYLE

CODE	L	H	T/Mt	Mt
50.950	150	67.00	100	■

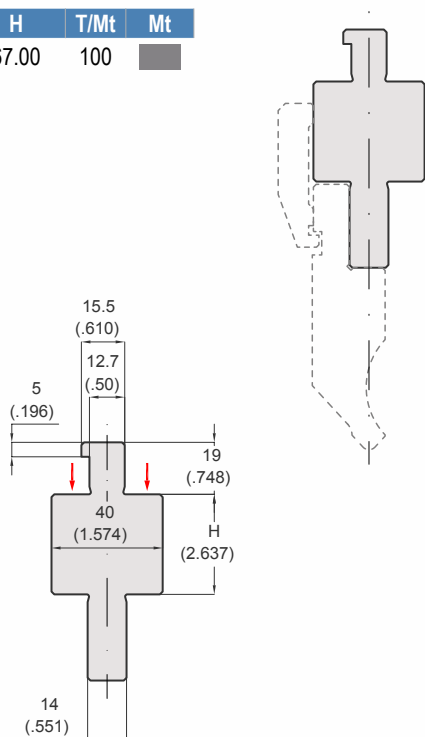

457.2 mm | 18" inches

USA - EU ADAPTER

CODE	L	H	T/Mt	Mt
60.980	835	35.00	100	■

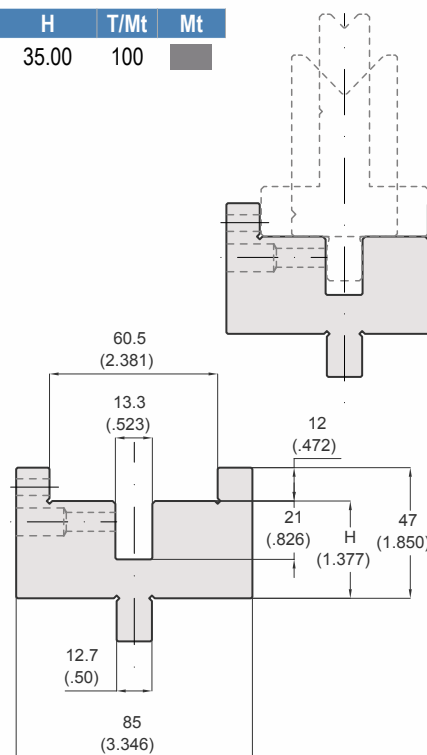

457.2 mm | 18" inches

USA - EU - WILA LOWER ADAPTER

PUNZONI / PUNCHES COLGAR STYLE

I PUNZONI SONO PRODOTTI A RICHIESTA NELLE LUNGHEZZE DI: 525 mm E FRAZIONATI (495 mm, 500 mm)
 THE PUNCHES ARE PRODUCED ON REQUEST IN THE FOLLOWING LENGTHS: 525 mm AND SECTIONED (495 mm, 500 mm)

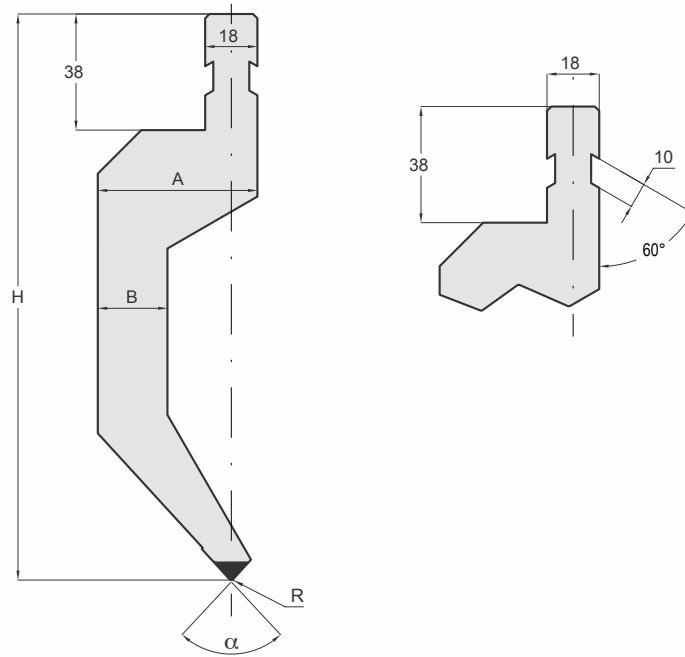

525 mm | 495 mm, 500 mm SECTIONED

LEGENDA	α = ANGOLO	R = RAGGIO	H = ALTEZZA
LEGEND	α = ANGLE	R = RADIUS	H = HEIGHT

MODELLI SU RICHIESTA / MODELS ON REQUEST

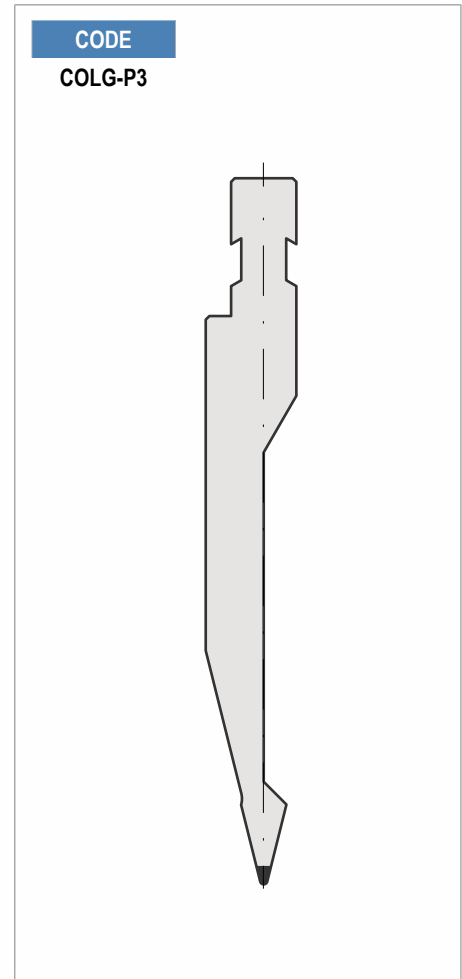
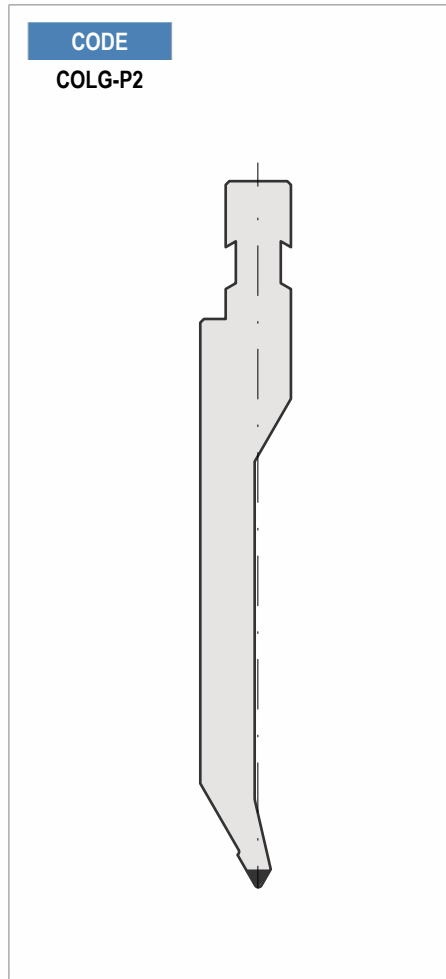
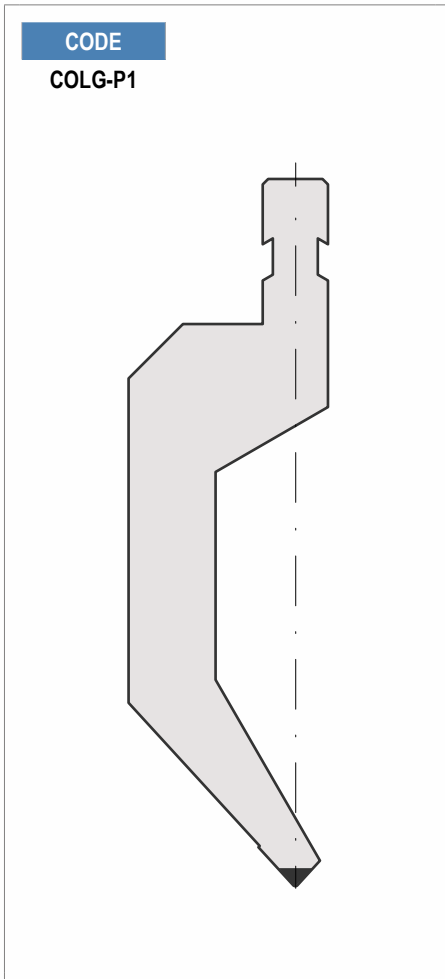

PUNZONI / PUNCHES COLLY STYLE

I PUNZONI SONO PRODOTTI A RICHIESTA NELLE LUNGHEZZE DI: 1020 mm E FRAZIONATI (1250 mm)

THE PUNCHES ARE PRODUCED ON REQUEST IN THE FOLLOWING LENGTHS: 1020 mm AND SECTIONED (1250 mm)

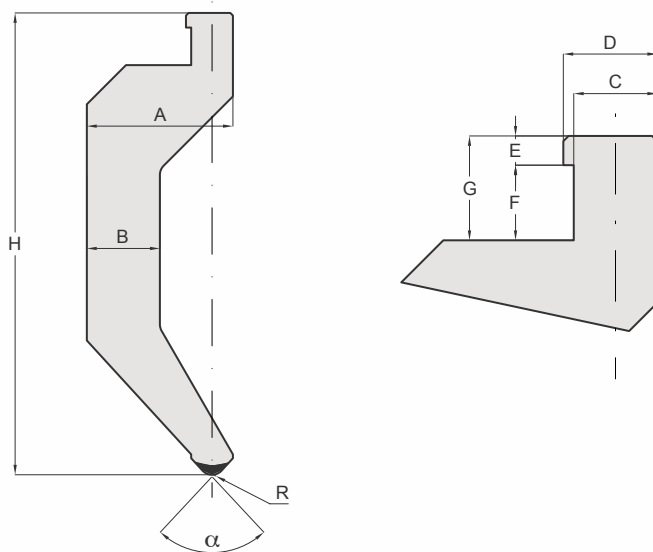

1020 mm | 1250 mm SECTIONED

LEGENDA	α = ANGOLO	R = RAGGIO	H = ALTEZZA
LEGEND	α = ANGLE	R = RADIUS	H = HEIGHT

MATRICI / DIES COLLY STYLE

LE MATRICI SONO PRODOTTE SU RICHIESTA NELLE LUNGHEZZE DI: 1020 mm E FRAZIONATI (990 mm)

THE DIES ARE PRODUCED ON REQUEST IN THE FOLLOWING LENGTHS: 1020 mm AND SECTIONED (990 mm)

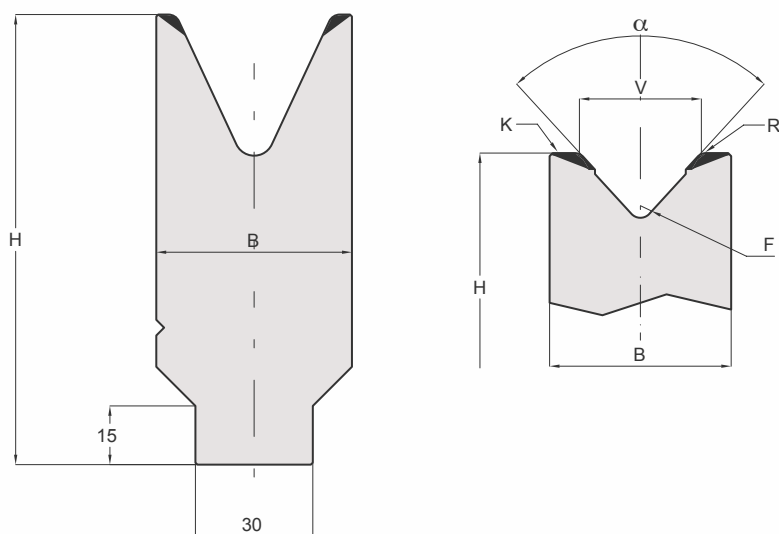

1020 mm | 1250 mm SECTIONED

LEGENDA	α = ANGOLO	V = AMPIEZZA CAVA	R = RAGGIO	H = ALTEZZA	B = BASE
LEGEND	α = ANGLE	V = DIE OPENING	R = RADIUS	H = HEIGHT	B = WIDTH

SUPPORTI E LAME / HOLDERS AND BLADES **HÄMMERLE STYLE**

PRODOTTI A RICHIESTA
PRODUCTS ON REQUEST

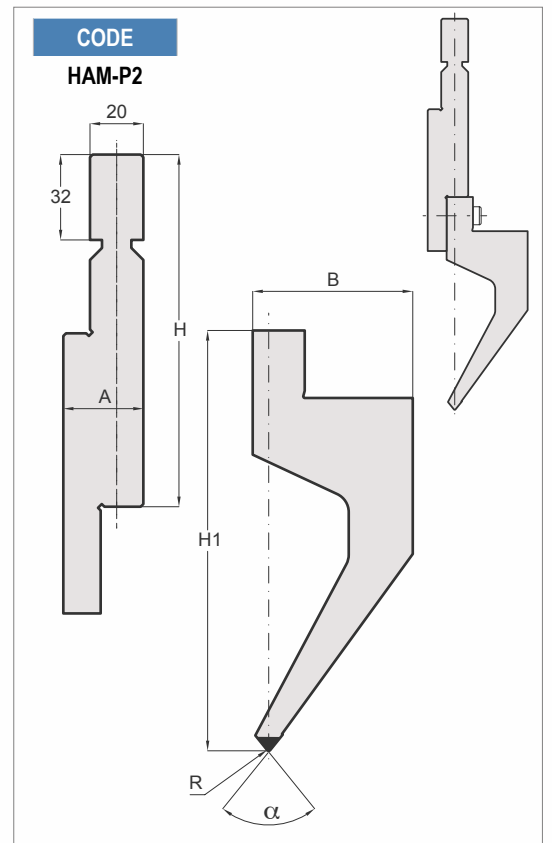
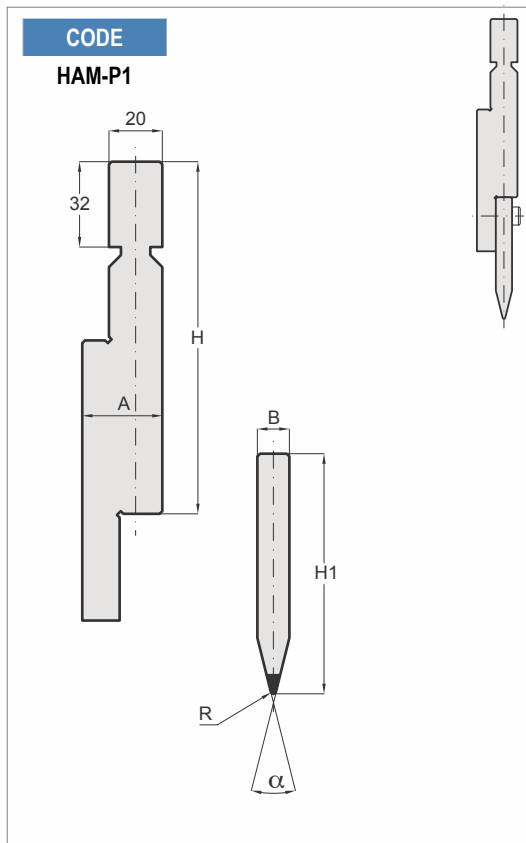

CODE

H =

H1 =

A =

B =

R =

α =

SPECIFICARE DIMENSIONI / SPECIFY DIMENSIONS

MATRICI / DIES **HÄMMERLE STYLE**

LE MATRICI SONO PRODOTTE SU RICHIESTA
THE DIES ARE PRODUCED ON REQUEST

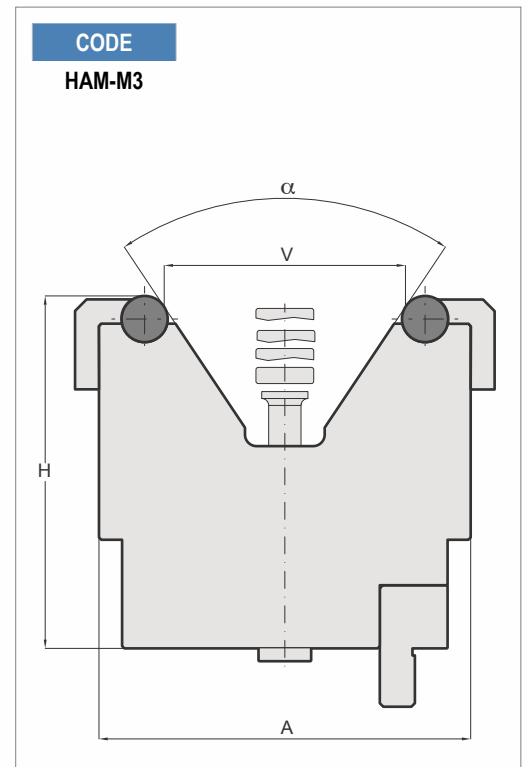
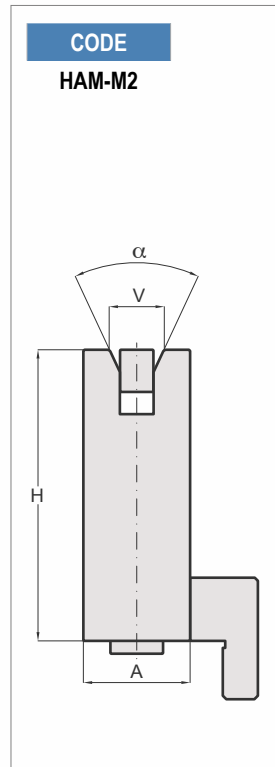
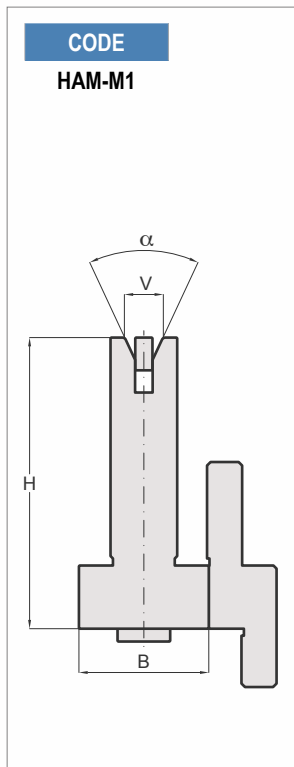

CODE

H =

A =

B =

R =

α =

SPECIFICARE DIMENSIONI / SPECIFY DIMENSIONS

PUNZONI / PUNCHES EHT STYLE

I PUNZONI SONO PRODOTTI A RICHIESTA NELLE LUNGHEZZE DI: 2100 mm, 2600 mm, 3100 mm, 3600 mm E 4100 mm (FRAZIONATI)

THE PUNCHES ARE PRODUCED ON REQUEST IN THE FOLLOWING LENGTHS: 2100 mm, 2600 mm, 3100 mm, 3600 mm AND 4100 mm (SECTIONED)

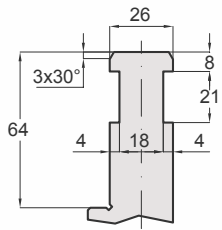

CODE

H =

B =

R =

α =

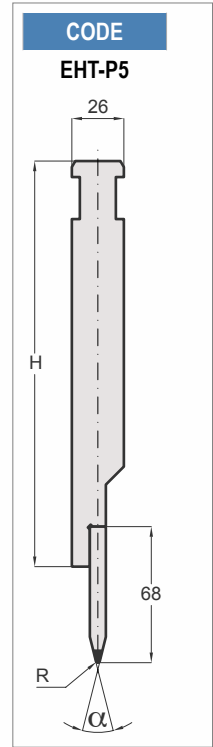
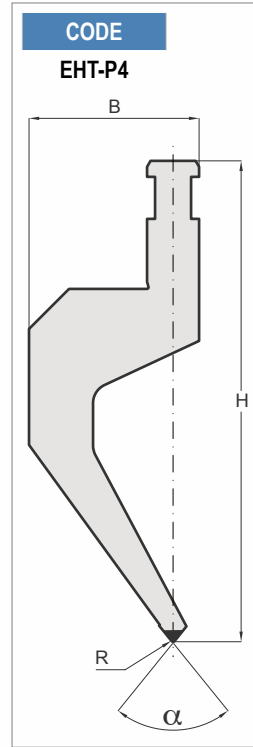
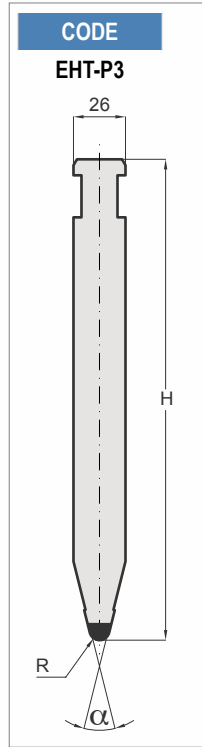
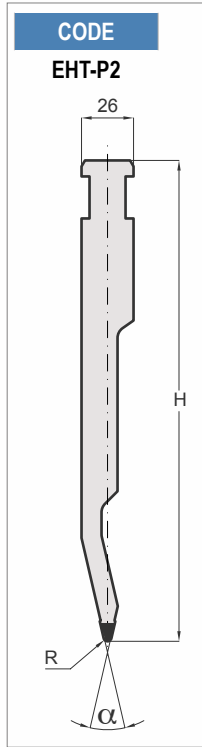
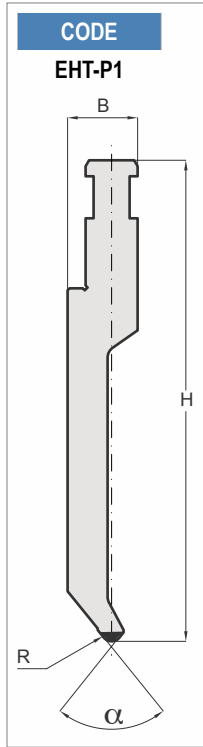

2100 mm | 2600 mm | 3100 mm | 3600 mm | 4100 mm (SECTIONED)

SPECIFICARE DIMENSIONI / SPECIFY DIMENSIONS

MATRICI / DIES EHT STYLE

LE MATRICI SONO PRODOTTE SU RICHIESTA NELLE LUNGHEZZE DI: 2100 mm, 2600 mm, 3100 mm, 3600 mm E 4100 mm (FRAZIONATI)

THE DIES ARE PRODUCED ON REQUEST IN THE FOLLOWING LENGTHS: 2100 mm, 2600 mm, 3100 mm, 3600 mm AND 4100 mm (SECTIONED)

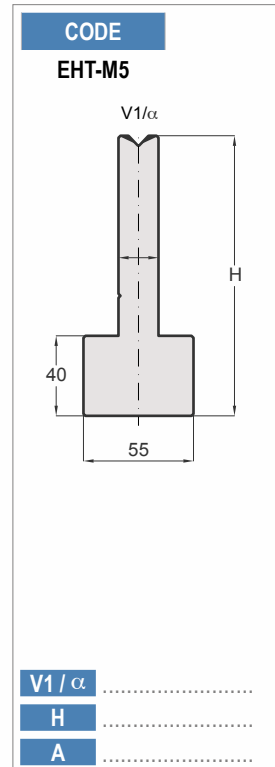
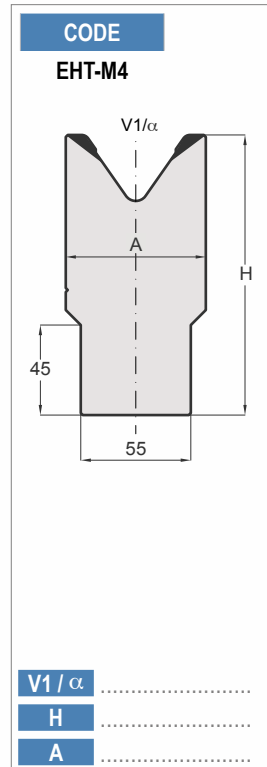
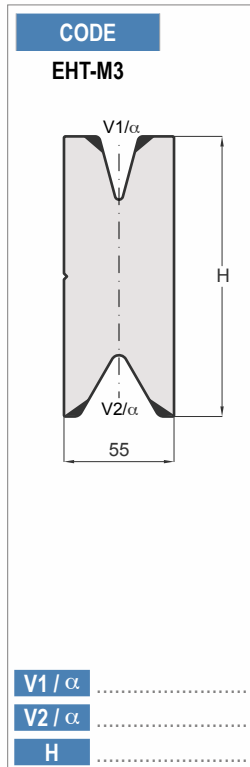
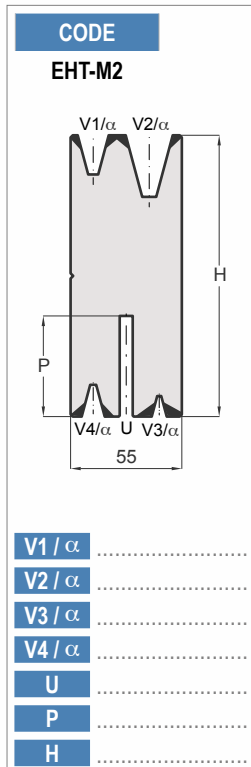
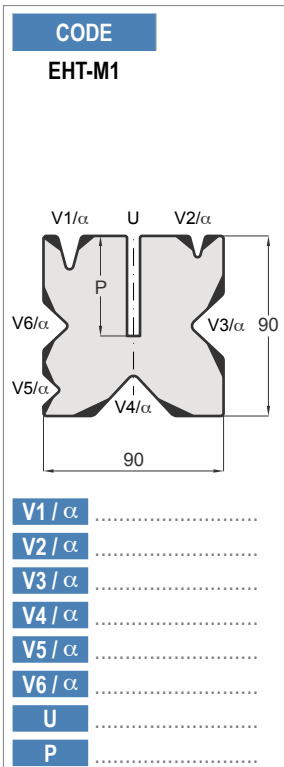

2100 mm | 2600 mm | 3100 mm | 3600 mm | 4100 mm (SECTIONED)

SPECIFICARE DIMENSIONI / SPECIFY DIMENSIONS

PUNZONI / PUNCHES **NEWTON STYLE**

I PUNZONI SONO PRODOTTI A RICHIESTA NELLE LUNGHEZZE DI: 510 mm, 1030 mm E FRAZIONATI (1010 mm)
 THE PUNCHES ARE PRODUCED ON REQUEST IN THE FOLLOWING LENGTHS: 510 mm, 1030 mm AND SECTIONED (1010 mm)

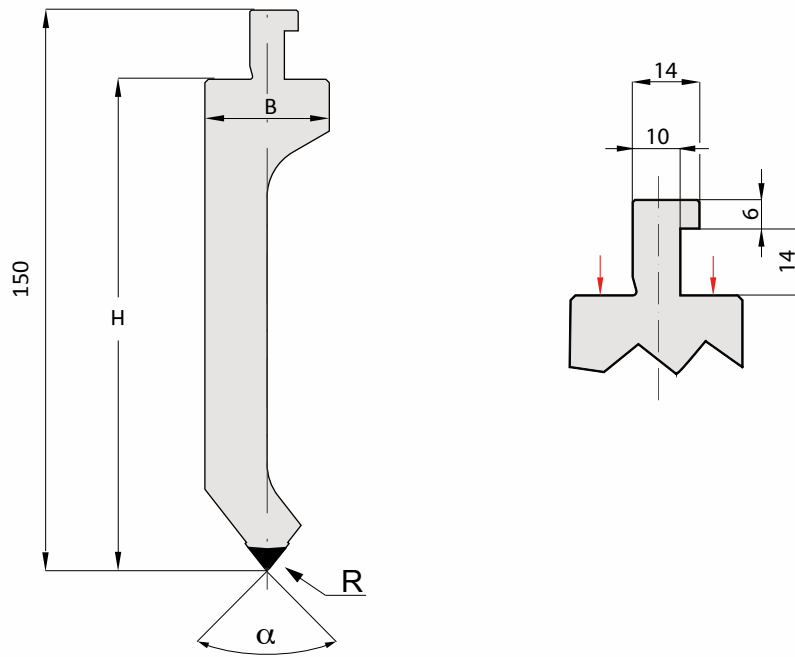

510 mm | 1030 mm | 1010 mm SECTIONED

LEGENDA	α = ANGOLO	R = RAGGIO	H = ALTEZZA
LEGEND	α = ANGLE	R = RADIUS	H = HEIGHT

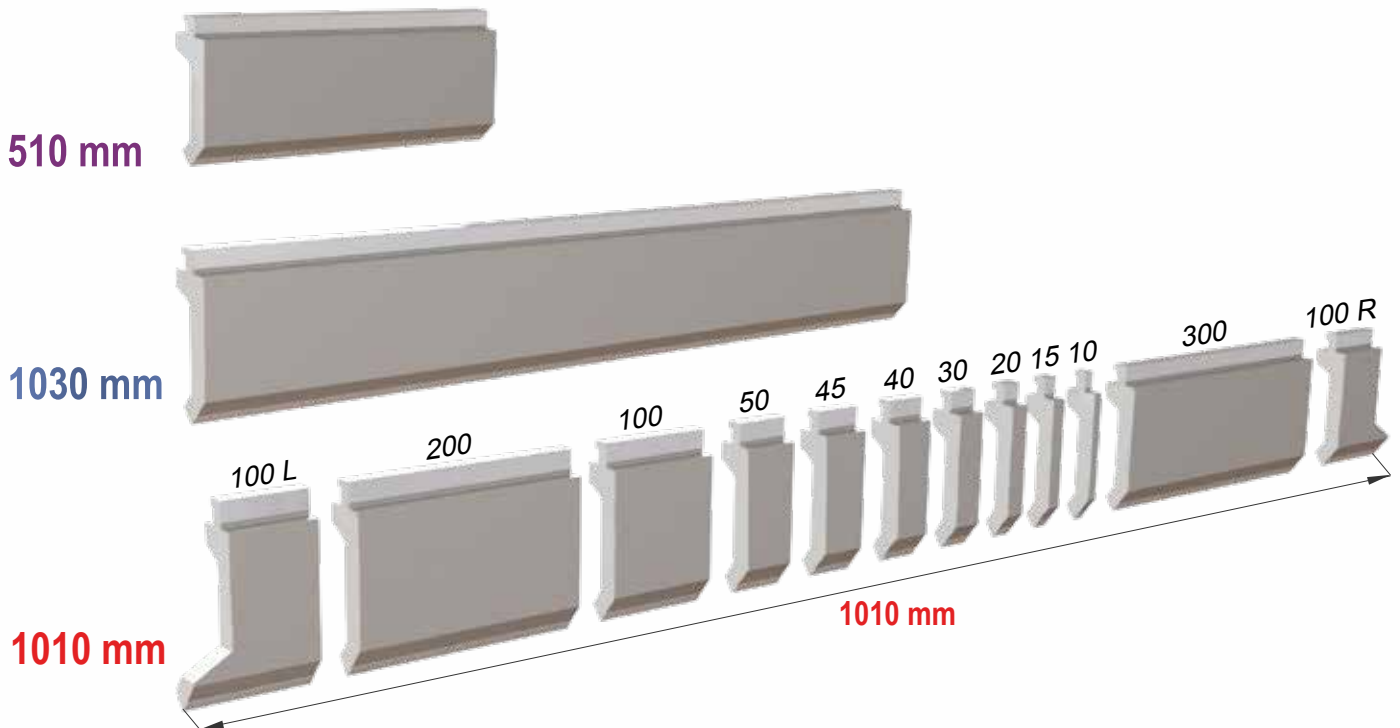

IL CARICO MASSIMO DELLE SCARPETTE CORRISPONDE AL 50% DEL CARICO MASSIMO INDICATO SUL PUNZONE.
 THE MAX LOAD OF THE HORN EXTENSIONS IS 50% OF THE MAX LOAD OF THE PUNCH.

PUNZONI / PUNCHES ADATTATORI / ADAPTERS **NEWTON STYLE**

CODE	L	H	T/Mt	Mt
50.930	150	100.00	100	■

ADATTATORE
ADAPTER
NEWTON / AMADA

CODE	L	H	T/Mt	Mt
50.935	150	100.00	100	■

ADATTATORE
ADAPTER
AMADA / NEWTON

CODE	α	R	H	T/Mt	Mt
18.100	76°	1.00	130.00	100	■

510 mm
1030 mm
1010 mm
SECTIONED



MATRICI / DIES *NEWTON STYLE*

CODE	α	H	T/Mt	Mt
28.820	60° - 80°	90	80	■

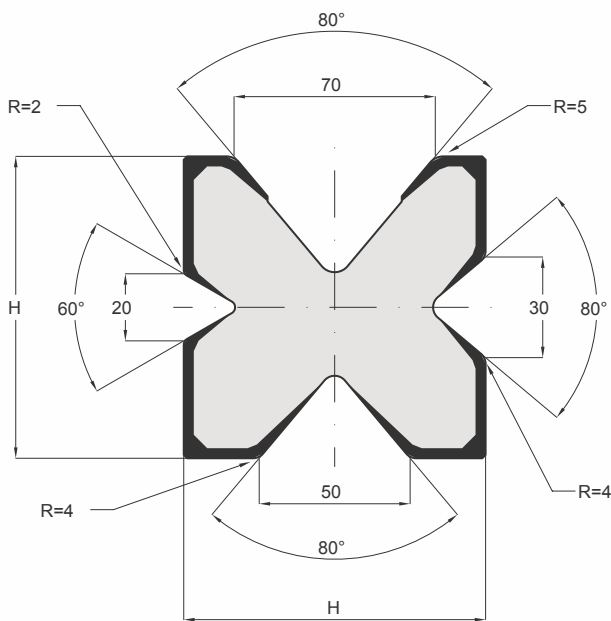

415 mm | 835 mm | 805 mm SECTIONED

LE MATRICI SONO PRODOTTE SU RICHIESTA NELLE LUNGHEZZE DI: 415 mm, 835 mm E 805 mm (FRAZIONATI)
 THE DIES ARE PRODUCED ON REQUEST IN THE FOLLOWING LENGTHS: 415 mm, 835 mm AND 805 mm (SECTIONED)

MATRICI / DIES *NEWTON STYLE*

CODE	α	H	T/Mt	Mt
28.100	80°	90	80	■

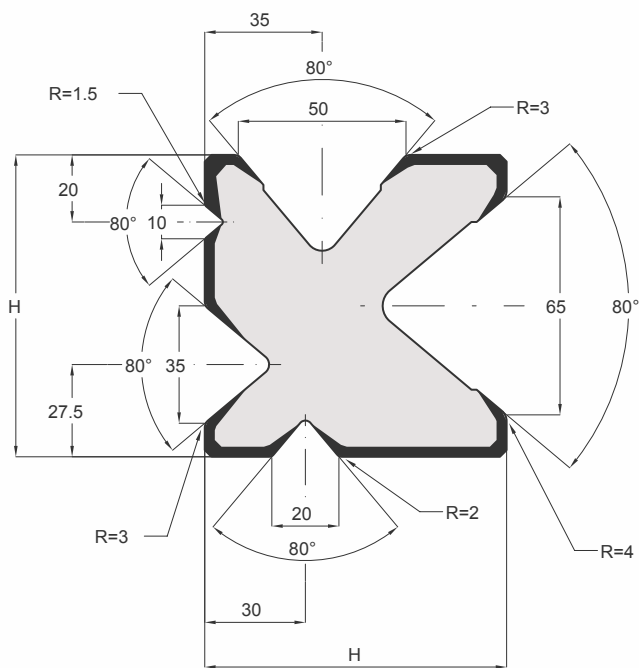

510 mm | 1030 mm | 1010 mm SECTIONED

LE MATRICI SONO PRODOTTE SU RICHIESTA NELLE LUNGHEZZE DI: 510 mm, 1030 mm E 1010 mm (FRAZIONATI)
 THE DIES ARE PRODUCED ON REQUEST IN THE FOLLOWING LENGTHS: 510 mm, 1030 mm AND 1010 mm (SECTIONED)

PUNZONI / PUNCHES WEINBRENNER STYLE

I PUNZONI SONO PRODOTTI A RICHIESTA NELLE LUNGHEZZE DI: 2050 mm, 2550 mm, 3050 mm, 3550 mm E 4050 mm (FRAZIONATI)

THE PUNCHES ARE PRODUCED ON REQUEST IN THE FOLLOWING LENGTHS: 2050 mm, 2550 mm, 3050 mm, 3550 mm AND 4050 mm (SECTIONED)

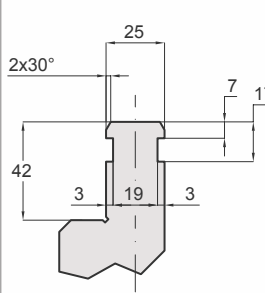

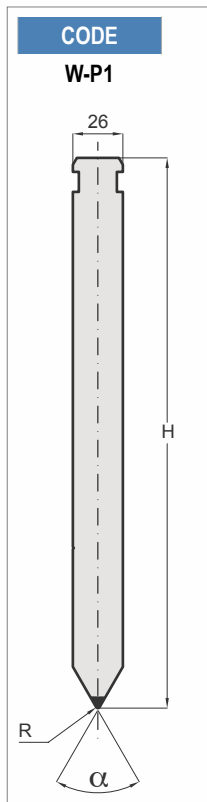
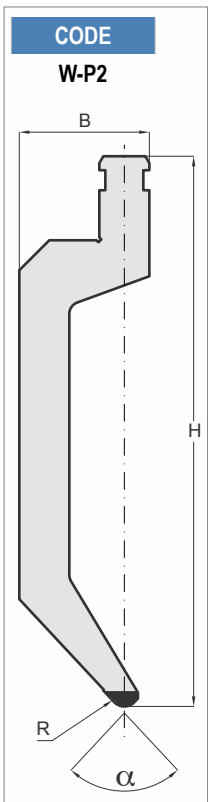
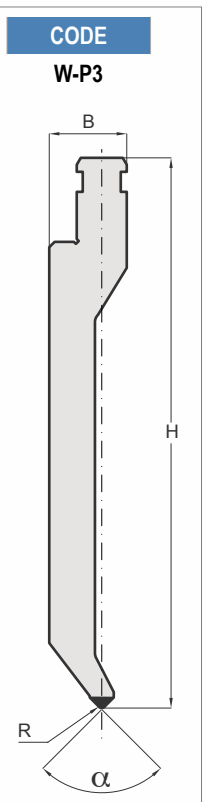
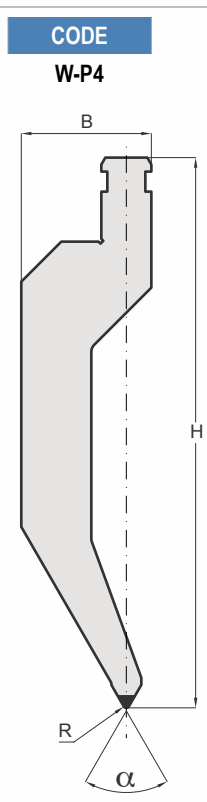
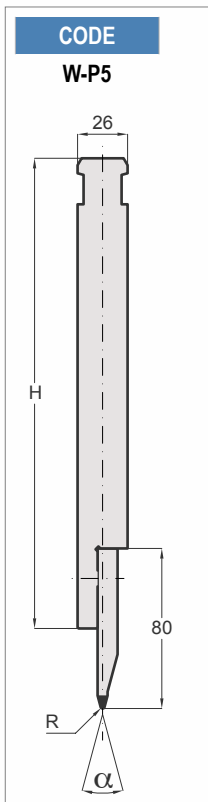
CODE	CODE	CODE	CODE	CODE
W-P1	W-P2	W-P3	W-P4	W-P5
				

CODE
 H =
 B =
 R =
 α =

2050 mm | 2550 mm | 3050 mm | 3550 mm | 4050 mm (SECTIONED)

SPECIFICARE DIMENSIONI / SPECIFY DIMENSIONS

MATRICI / DIES WEINBRENNER STYLE

LE MATRICI SONO PRODOTTE SU RICHIESTA NELLE LUNGHEZZE DI: 2050 mm, 2550 mm, 3050 mm, 3550 mm E 4050 mm (FRAZIONATI)

THE DIES ARE PRODUCED ON REQUEST IN THE FOLLOWING LENGTHS: 2050 mm, 2550 mm, 3050 mm, 3550 mm AND 4050 mm (SECTIONED)

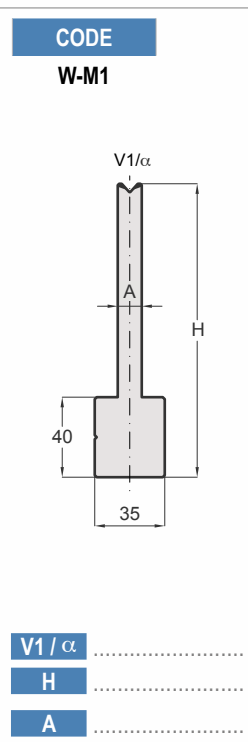
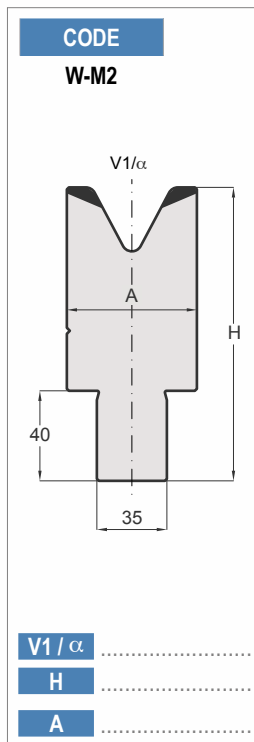
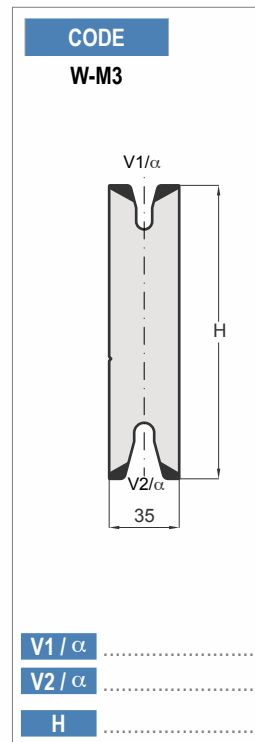
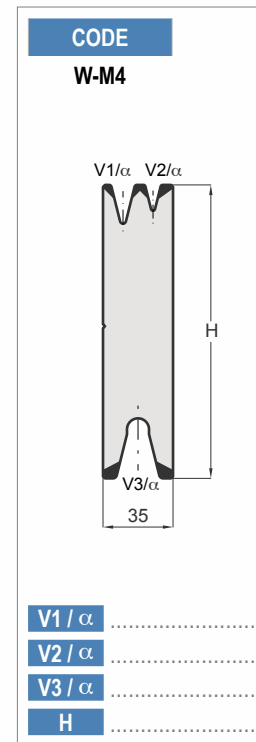
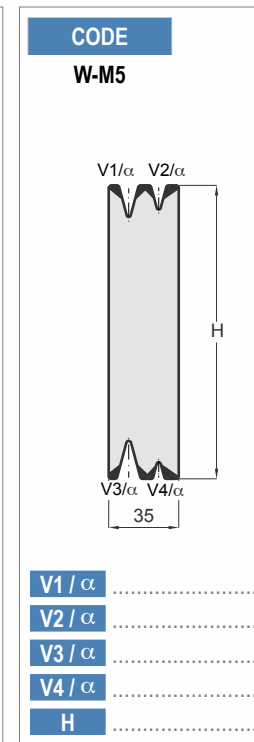
CODE	CODE	CODE	CODE	CODE
W-M1	W-M2	W-M3	W-M4	W-M5
				

W-M1: $V1/\alpha$, H, A, 40, 35
 W-M2: $V1/\alpha$, H, A, 40, 35
 W-M3: $V1/\alpha$, $V2/\alpha$, H, 35
 W-M4: $V1/\alpha$, $V2/\alpha$, $V3/\alpha$, H, 35
 W-M5: $V1/\alpha$, $V2/\alpha$, $V3/\alpha$, $V4/\alpha$, H, 35

W-M1: $V1/\alpha$
 H
 A
 W-M2: $V1/\alpha$
 H
 A
 W-M3: $V1/\alpha$
 $V2/\alpha$
 H
 W-M4: $V1/\alpha$
 $V2/\alpha$
 $V3/\alpha$
 H
 W-M5: $V1/\alpha$
 $V2/\alpha$
 $V3/\alpha$
 $V4/\alpha$
 H

2050 mm | 2550 mm | 3050 mm | 3550 mm | 4050 mm (SECTIONED)

SPECIFICARE DIMENSIONI / SPECIFY DIMENSIONS



AMADA / TRUMPF / WILA / BYSTRONIC LVD / EHT / WEINBRENNER STYLE

LAME / BLADES

SUPPORTO PER LAME / BLADES HOLDER

INSERTI A (Z) / Z TOOL INSERTS

SUPPORTI PER INSERTI A (Z) / Z TOOL HOLDERS

INSERTI RAGGIATI / RADIUS INSERTS

SUPPORTI PER INSERTI RAGGIATI / RADIUS INSERT HOLDERS

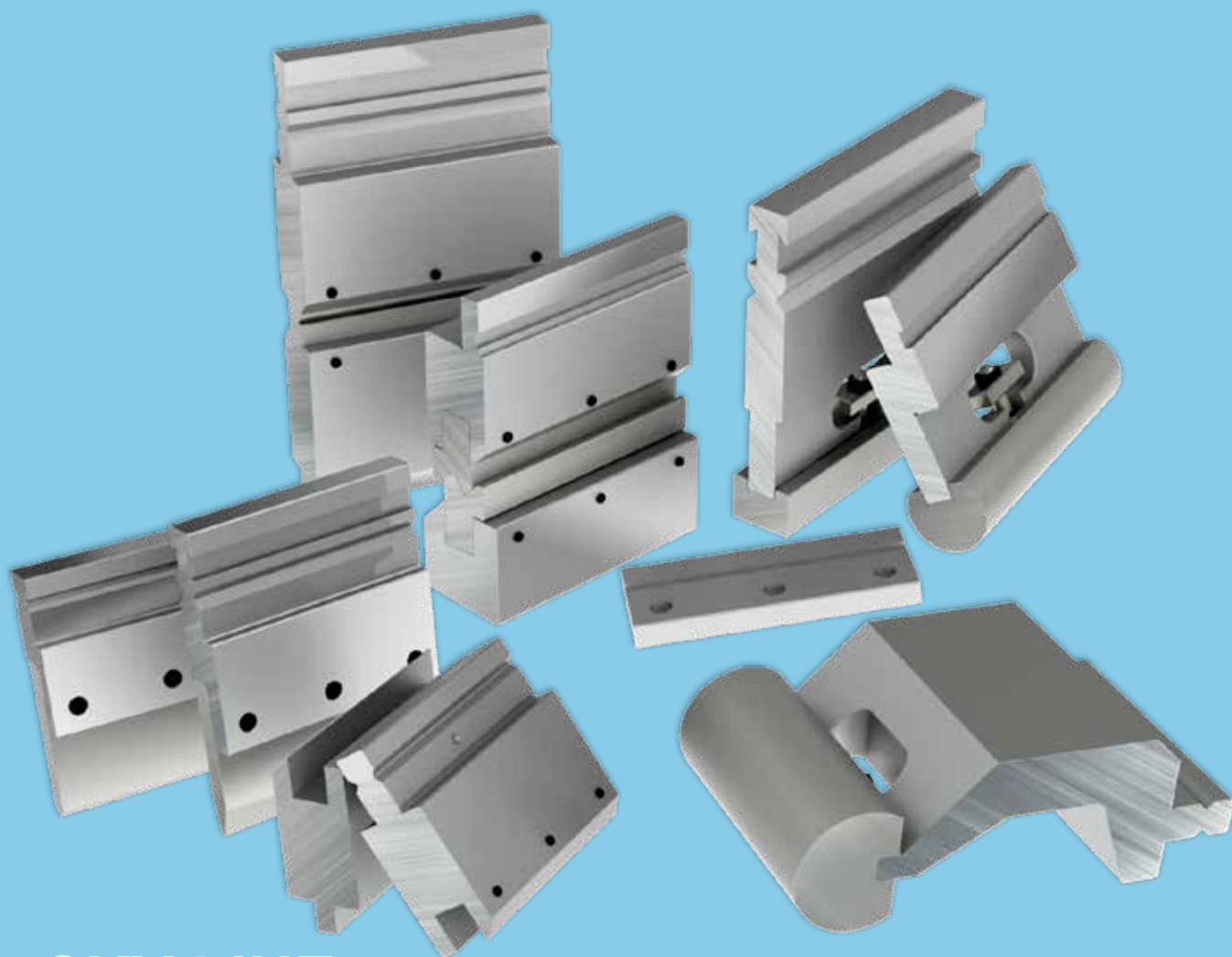

SKY LINE

AMADA / TRUMPF / WILA / BYSTRONIC
LVD / EHT / WEINBRENNER STYLE



SUPPORTO PER LAME / BLADES HOLDER

AMADA - TRUMPF - WILA - BYSTRONIC - LVD - EHT - WEINBRENNER STYLE

CODE	H	T/Mt	Mt
10.400	60.00	25	■

100 mm
200 mm
300 mm
500 mm
488 mm SECTIONED

AMADA / PROMECAM

CODE	H	T/Mt	Mt
15.760	120.00	100	■

100 mm
200 mm
300 mm
500 mm
550 mm SECTIONED

TRUMPF - WILA - LVD

CODE	H	T/Mt	Mt
15.755	57.00	100	■

100 mm
200 mm
300 mm
500 mm
550 mm SECTIONED

TRUMPF - WILA - LVD

CODE	H	T/Mt	Mt
14.280	95.00	100	■

100 mm
200 mm
300 mm
500 mm
550 mm SECTIONED

BYSTRONIC - R

CODE	H	T/Mt	Mt
14.281	90.00	100	■

100 mm
200 mm
300 mm
500 mm
550 mm SECTIONED

BYSTRONIC - S

CODE	H	T/Mt	Mt
14.282	70.00	100	■

100 mm
200 mm
300 mm
500 mm
550 mm SECTIONED

BYSTRONIC - RFA

CODE	H	T/Mt	Mt
16.070	120.00	100	■

100 mm
200 mm
300 mm
500 mm
550 mm SECTIONED

LVD

CODE	H	T/Mt	Mt
17.070	96.00	100	■

100 mm
200 mm
300 mm
500 mm
550 mm SECTIONED

EHT

CODE	H	T/Mt	Mt
17.570	123.00	100	■

100 mm
200 mm
300 mm
500 mm
550 mm SECTIONED

WEINBRENNER

LAME / BLADES

AMADA - TRUMPF - WILA - BYSTRONIC - LVD - EHT - WEINBRENNER STYLE

CODE	α	R	H	T/Mt	Mt
15.776	86°	1.00	100.00	100	■
15.774	84°	1.00	100.00	100	■
15.769	28°	6.00	100.00	100	■
15.768	28°	5.00	100.00	100	■
15.767	28°	4.00	100.00	100	■
15.766	28°	3.00	100.00	100	■
15.765	28°	2.00	100.00	100	■
15.763	28°	1.00	100.00	100	■
15.761	28°	0.50	100.00	100	■

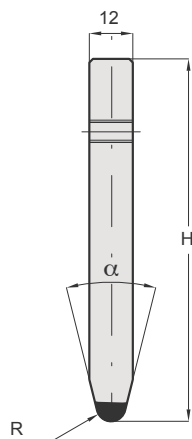

100 mm | 200 mm | 300 mm | 500 mm | 550 mm SECTIONED

LEGENDA	α = ANGOLO	R = RAGGIO	H = ALTEZZA	K = PARTI USURABILI
LEGEND	α = ANGLE	R = RADIUS	H = HEIGHT	K = WEAR PARTS

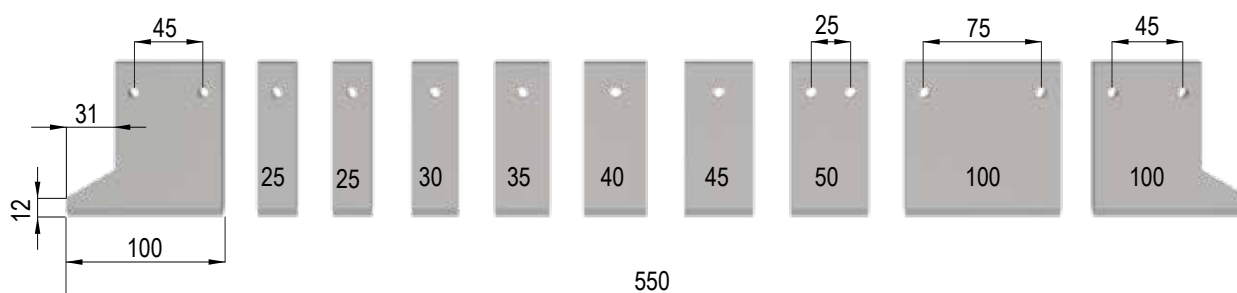
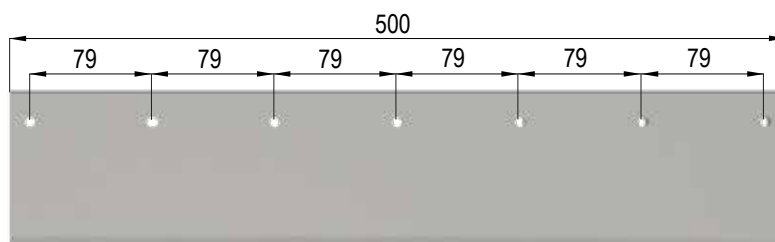
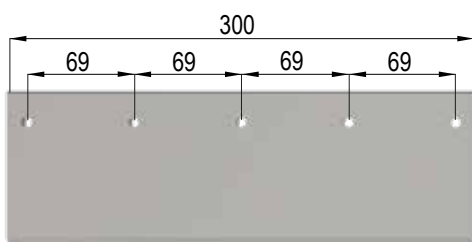
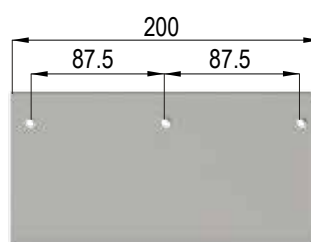
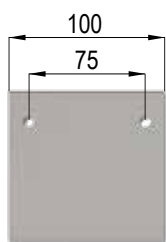

IL CARICO MASSIMO DELLE SCARPETTE CORRISPONDE AL 50% DEL CARICO MASSIMO INDICATO SOPRA LA LAMA.
 THE MAX LOAD OF THE HORN EXTENSIONS IS 50% OF THE MAX LOAD OF THE BLADE.

SUPPORTI PER INSERTI A (Z) / Z TOOL HOLDERS

AMADA - TRUMPF - WILA - BYSTRONIC - LVD - EHT - WEINBRENNER STYLE

CODE	H1	H2	T/Mt	Mt
40.419	42.00	36.00	100	■

415 mm
835 mm

AMADA / PROMECAM

CODE	H1	H2	T/Mt	Mt
15.050	62.00	64.00	100	■

415 mm
835 mm

TRUMPF - WILA

CODE	H1	H2	T/Mt	Mt
16.050	144	90	100	■

415 mm
835 mm

LVD

CODE	H1	H2	T/Mt	Mt
16.060	62.00	90.00	100	■

415 mm
835 mm

LVD

CODE	H1	H2	T/Mt	Mt
17.050	189	64	100	■

415 mm
835 mm

EHT

CODE	H1	H2	T/Mt	Mt
17.550	139	64	100	■

415 mm
835 mm

WEINBRENNER

CODE	H1	H2	T/Mt	Mt
14.095	42	64	100	■

415 mm
835 mm

EURO - BYSTRONIC

CODE	H1	H2	T/Mt	Mt
14.090	101	64	100	■

415 mm
835 mm

BYSTRONIC - S

CODE	H1	H2	T/Mt	Mt
14.085	101	64	100	■

415 mm
835 mm

BYSTRONIC - R

CODE	H1	H2	T/Mt	Mt
14.080	121	64	100	■

415 mm
835 mm

BYSTRONIC - RFA

INSERTI A (Z) / Z TOOL INSERTS

AMADA - TRUMPF - WILA - BYSTRONIC - LVD - EHT - WEINBRENNER STYLE

LEGENDA	Z = SALTO AZ	α = ANGOLO	R = RAGGIO	T/mt = CARICO MAX	Mt = MATERIALE	T = SPESSORE MAX
LEGEND	Z = Z OFFSET	α = ANGLE	R = RADIUS	T/mt = MAX LOAD	Mt = MATERIAL	T = MAX THICKNESS

CODE	Z	α	R	T/Mt	Mt	T= MAX THICKNESS
40.500				100		

415 mm | 835 mm

CODE	Z	α	R	T/Mt	Mt	T= MAX THICKNESS
40.510	1.00	160°	0.5	100		1 mm
40.515	1.50	160°	0.5	100		1.2 mm
40.520	2.00	150°	0.5	100		1.5 mm
40.525	2.50	140°	0.5	100		1.5 mm

415 mm | 835 mm

CODE	Z	α	R	T/Mt	Mt	T= MAX THICKNESS
40.511	1.00	90°	0.3	100		0.5 mm
40.516	1.50	90°	0.3	100		0.5 mm
40.521	2.00	90°	0.5	100		0.5 mm
40.526	2.50	90°	0.5	100		0.8 mm
40.530	3.00	90°	0.5	100		1 mm
40.535	3.50	90°	0.5	100		1 mm
40.540	4.00	90°	0.5	100		1.2 mm
40.545	4.50	90°	0.5	100		1.2 mm
40.550	5.00	90°	0.5	100		1.5 mm
40.555	5.50	90°	0.5	100		1.5 mm
40.560	6.00	90°	0.5	100		1.5 mm
40.565	6.50	90°	0.5	100		1.5 mm
40.570	7.00	90°	0.5	100		1.5 mm
40.575	7.50	90°	0.5	100		1.6 mm
40.580	8.00	90°	0.5	100		1.6 mm

415 mm | 835 mm

CODE	Z	α	R	T/Mt	Mt	T= MAX THICKNESS
40.585	8.50	90°	0.8	100		2 mm
40.590	9.00	90°	0.8	100		2 mm
40.610	10.00	90°	0.8	100		2 mm
40.611	11.00	90°	1	100		2 mm
40.612	12.00	90°	1	100		2 mm







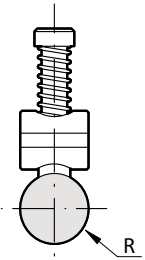

415 mm | 835 mm

CODE	Z	α	T	T/Mt	Mt	T= MAX THICKNESS
40.613	13.00	90°	1	100		2.5 mm
40.614	14.00	90°	1	100		2.5 mm
40.615	15.00	90°	1	100		3 mm

415 mm | 835 mm

INSERTI RAGGIATI / RADIUS INSERTS

AMADA

ACCIAIO - STEEL C45	CODE	Mt	R	L
	10.181		3.00	A
	10.182		3.50	A
	10.183		4.00	A
	10.184		4.50	A
	10.185		5.00	B
	10.186		5.50	B
	10.187		6.00	B
	10.188		6.50	B

LEGENDA	L = LATO	R = RAGGIO
LEGEND	L = SIDE	R = RADIUS

CODE	T/Mt	Mt
10.180	80	

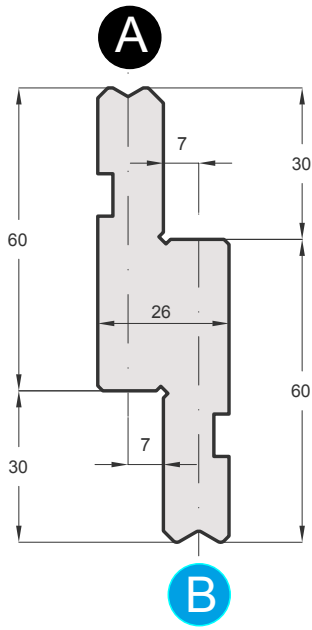

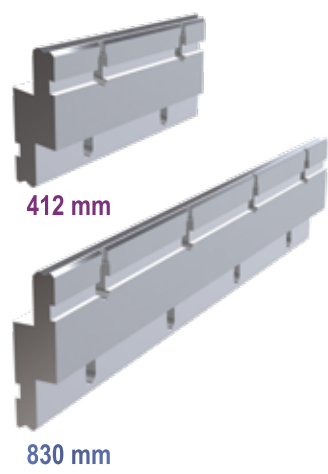

HOLDER AMADA

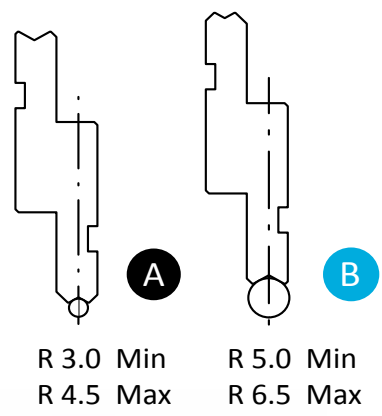



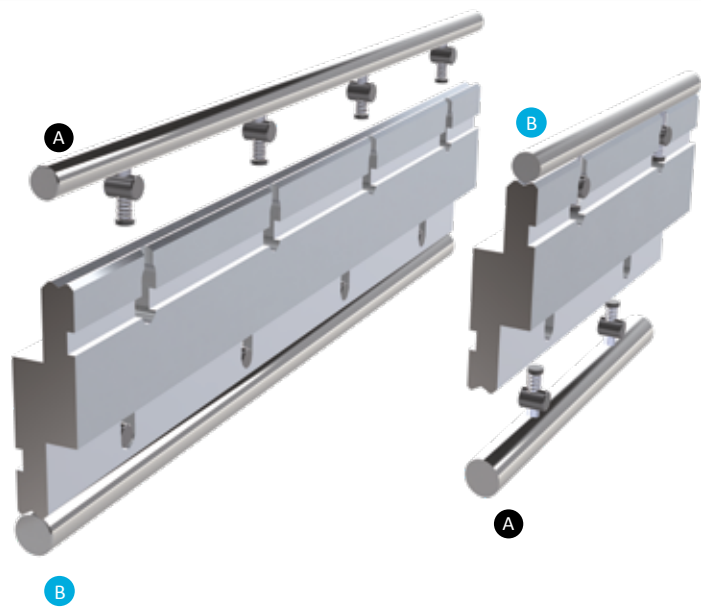

CODE
40.003

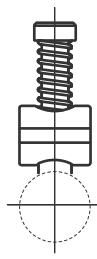

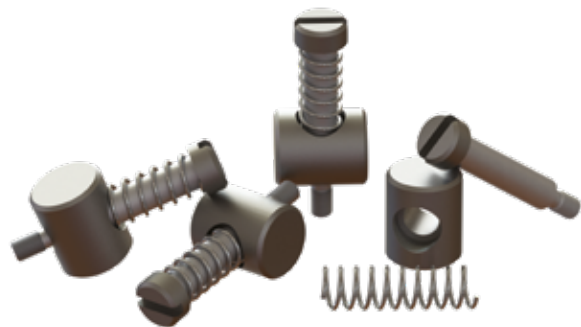

SPARE PARTS

INSERTI RAGGIATI / RADIUS INSERTS

AMADA - TRUMPF - WILA - BYSTRONIC - LVD - EHT - WEINBRENNER STYLE

ACCIAIO - STEEL C45	CODE	Mt	R	A	B	CODE	Mt	STEEL 42CrMo4 (UNI EN 10083-93) NITRIDED 60-62 HRC
<p>415 mm 835 mm</p>	10.300	■	7.00	11.50		11.300	■	<p>415 mm 835 mm</p>
	10.301	■	7.50	11.50		11.301	■	
	10.302	■	8.00	13.00		11.302	■	
	10.303	■	9.00	16.00		11.303	■	
	10.304	■	10.00	16.00		11.304	■	
	10.305	■	11.00	16.00		11.305	■	
	10.306	■	11.50	19.00		11.306	■	
10.307	■	12.00	20.00		11.307	■		

<p>415 mm 835 mm</p>	10.308	■	12.50	16.00	21.00	11.308	■	<p>415 mm 835 mm</p>
	10.309	■	13.00	17.00	23.00	11.309	■	
	10.310	■	14.00	19.00	25.00	11.310	■	
	10.311	■	15.00	20.00	27.00	11.311	■	
	10.312	■	16.00	21.00	28.00	11.312	■	
	10.313	■	17.00	21.50	31.50	11.313	■	
	10.314	■	17.50	22.00	32.00	11.314	■	
	10.315	■	19.00	25.00	32.00	11.315	■	
	10.316	■	20.00	24.00	34.00	11.316	■	
	10.317	■	22.50	25.00	33.00	11.317	■	
	10.318	■	25.00	29.00	39.00	11.318	■	
	10.319	■	27.50	34.00	44.00	11.319	■	
	10.320	■	30.00	34.00	44.00	11.320	■	
	10.321	■	35.00	45.00	55.00	11.321	■	
	10.322	■	40.00	45.00	55.00	11.322	■	
	10.323	■	45.00	50.00	60.00	11.323	■	
10.324	■	50.00	54.00	64.00	11.324	■		

<p>415 mm 835 mm</p>	<table border="1"> <thead> <tr> <th>CODE</th> <th>Mt</th> </tr> </thead> <tbody> <tr> <td>10.325</td> <td>■</td> </tr> </tbody> </table>	CODE	Mt	10.325	■	<table border="1"> <thead> <tr> <th>R</th> <th>A</th> <th>B</th> </tr> </thead> <tbody> <tr> <td>17.00</td> <td>22.00</td> <td></td> </tr> </tbody> </table>	R	A	B	17.00	22.00		
	CODE	Mt											
10.325	■												
R	A	B											
17.00	22.00												
<p>ACCIAIO - STEEL C45 (UNI EN 10083 W.1. : 1.1191)</p>													

CODE
40.002

SPARE PARTS

SUPPORTI PER INSERTI RAGGIATI / RADIUS INSERTS HOLDERS

AMADA - TRUMPF - WILA - BYSTRONIC - LVD - EHT - WEINBRENNER STYLE

CODE	H	T/Mt	Mt
10.115	67.00	80	■

412 mm
830 mm

AMADA

CODE	H	T/Mt	Mt
10.116	115.00	80	■

412 mm
830 mm

AMADA

CODE	H	T/Mt	Mt
10.190	87.00	50	■

412 mm
830 mm

AMADA

CODE	H	T/Mt	Mt
10.191	115.00	50	■

412 mm
830 mm

AMADA

CODE	H	T/Mt	Mt
15.010	103.00	80	■

412 mm
830 mm

TRUMPF - WILA - LVD

CODE	H	T/Mt	Mt
15.014	160.00	80	■

412 mm
830 mm

TRUMPF - WILA - LVD

CODE	H	T/Mt	Mt
15.018	220.00	80	■

412 mm
830 mm

TRUMPF - WILA - LVD

CODE	H	T/Mt	Mt
16.010	170.00	80	■

412 mm
830 mm

LVD

CODE	H	T/Mt	Mt
17.010	200.00	80	■

412 mm
830 mm

EHT

SUPPORTI PER INSERTI RAGGIATI / RADIUS INSERTS HOLDERS

AMADA - TRUMPF - WILA - BYSTRONIC - LVD - EHT - WEINBRENNER STYLE

CODE	H	T/Mt	Mt
17.510	165.00	80	

412 mm
830 mm

WEINBRENNER

CODE	H	T/Mt	Mt
14.250	140.00	80	

412 mm
830 mm

BYSTRONIC - R

CODE	H	T/Mt	Mt
14.251	140.00	80	

412 mm
830 mm

BYSTRONIC - S

CODE	H	T/Mt	Mt
14.252	140.00	80	

412 mm
830 mm

BYSTRONIC - RFA





CORAL LINE

UNIBEND E ADATTATORI
UNIBEND AND ADAPTERS

SUPPORTI E MATRICI A RULLI
ADAPTERS AND ROLLER DIE

CONTENITORI E INSERTI IN POLIURETANO
POLYURETHANE INSERTS AND HOLDERS

CONTENITORI E INSERTI NYLON
NYLON INSERTS AND HOLDERS

PELLICOLE ANTIGRAFFIO E TENDIPELLICOLA
PROTECTIVE FILM AND FOLDERS



CORAL LINE

UTENSILI PER NON MARCARE
NO MARKING TOOLS



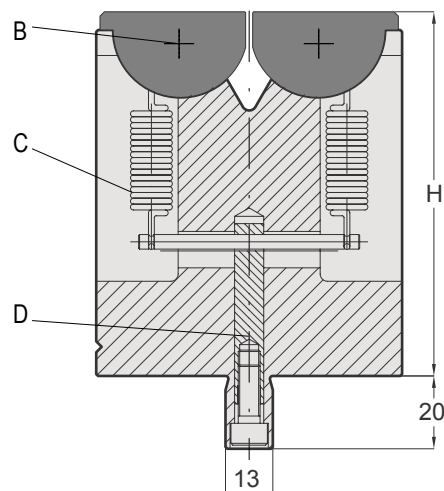
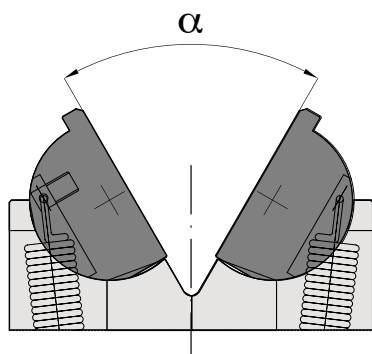

50 mm | 100 mm | 200 mm | 300 mm | 500 mm

LEGENDA	α = ANGOLO	B = INSERTO ROTANANTE	C = MOLLA A TRAZIONE	D = PERNO TENSORE	H = ALTEZZA
LEGEND	α = ANGLE	B = ROTATING TOOL	C = SPRING	D = PIN	H = HEIGHT

VANTAGGI DELLE MATRICI UNIBEND CON INSERTI ROTANTI:

- RIDUZIONE DEI TEMPI DI CAMBIO UTENSILE POICHE' CON LA STESSA MATRICE E' POSSIBILE PIEGARE SPESSORI DIVERSI
- RIDUZIONE DEL 90% DEI SEGNI DOVUTI ALLA PIEGATURA
- POSSIBILITA' DI PIEGARE PEZZI CON BORDI STRETTI
- RIDUZIONE DELLA DEFORMAZIONE DI FORI E ASOLE VICINI ALLA LINEA DI PIEGATURA

ADVANTAGES OF THE UNIBEND DIES WITH ROTATING INSERTS :

- LESS TOOL CHANGE
- REDUCTION OF THE 90% OF THE BENDING MARKS ON SHEET
- SUITABLE FOR V, RADIUS AND U-BENDING
- REDUCTION OF DEFORMATION OF HOLES AND SLOTS CLOSE TO THE BENDING LINE



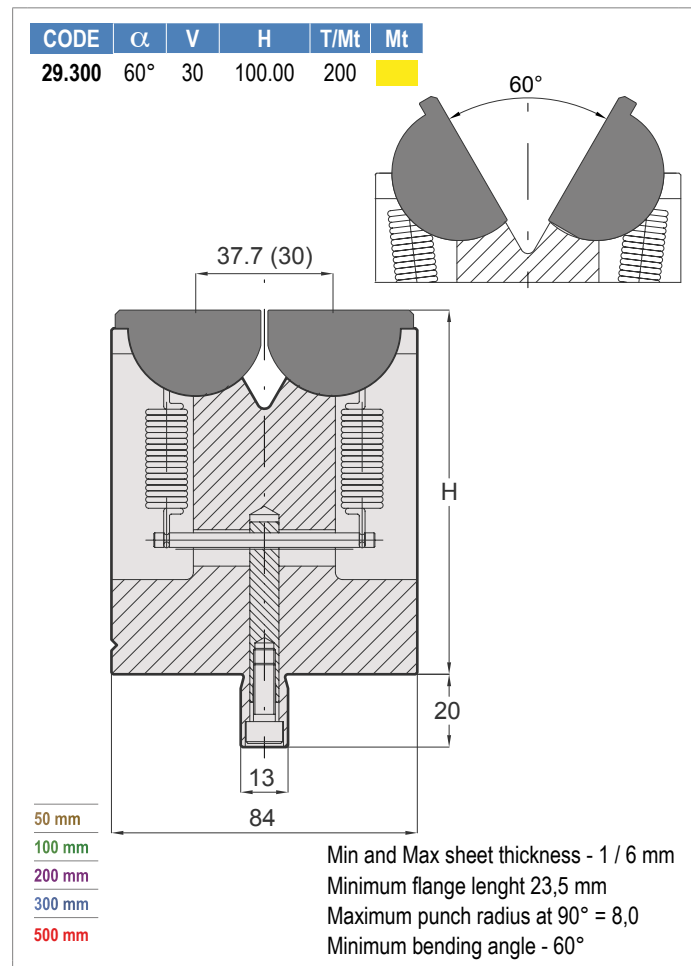
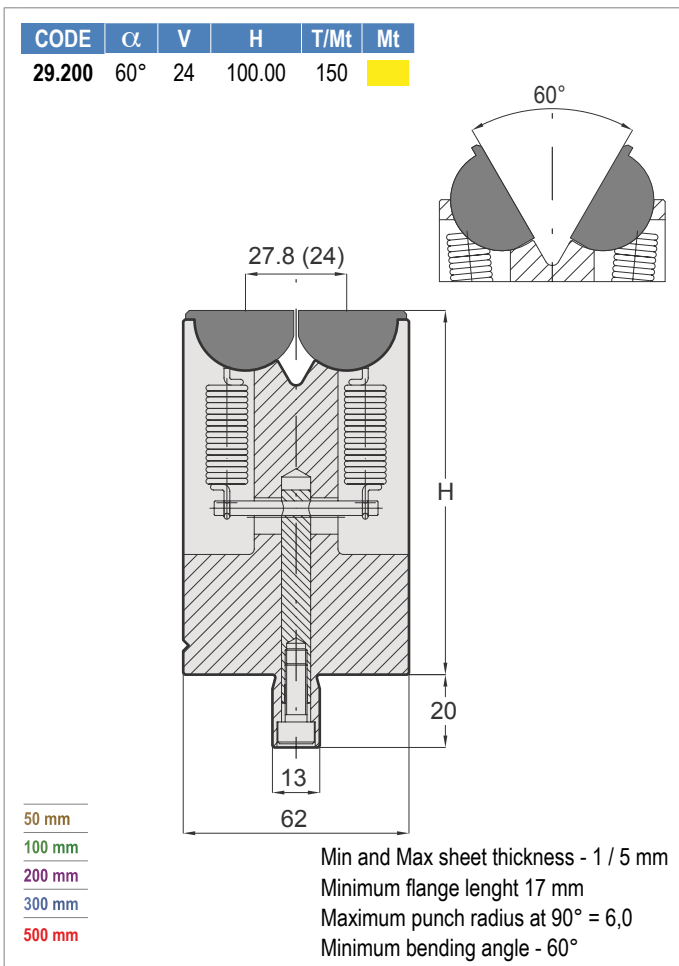
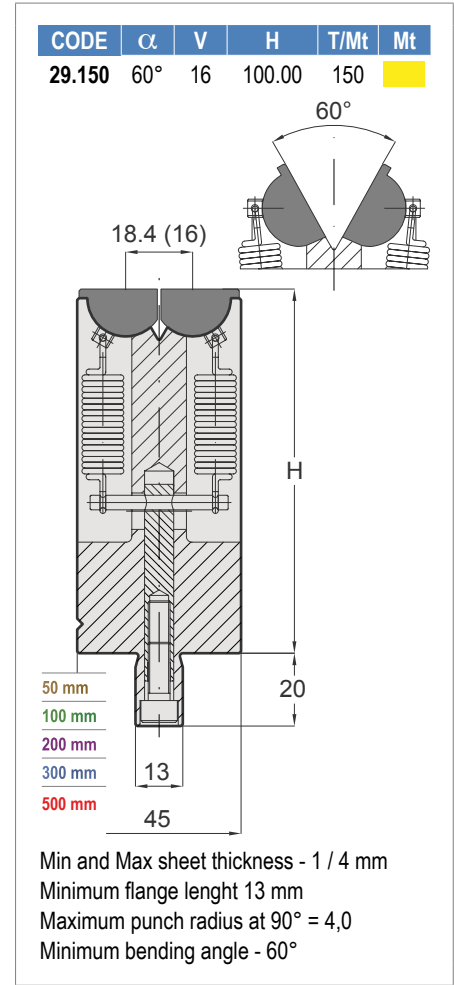
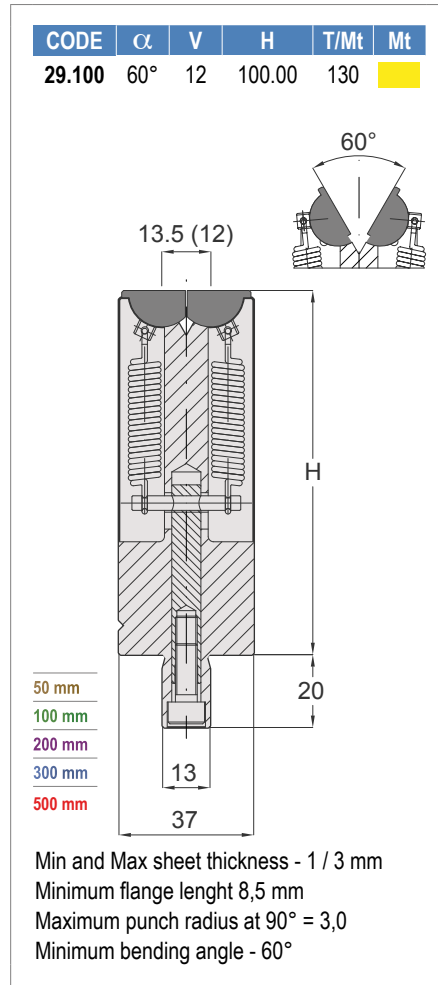
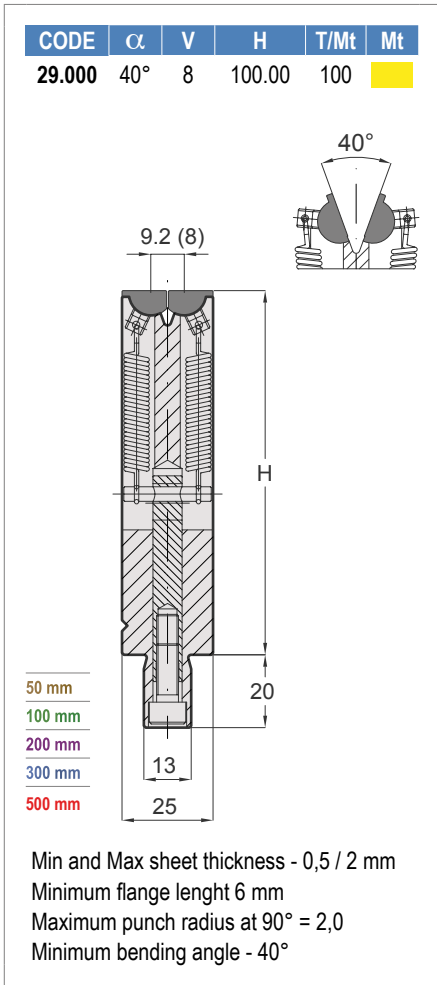

ADATTATORE INFERIORE - LOWER ADAPTER

CODE	H	T/Mt	Mt
60.910	30.00	100	■

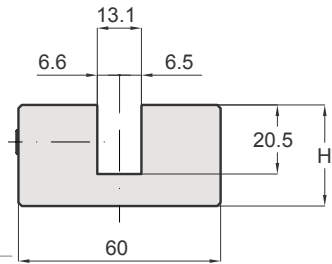
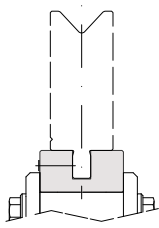

- 50 mm
- 100 mm
- 200 mm
- 300 mm
- 500 mm
- 1000 mm

ADATTATORE INFERIORE - LOWER ADAPTER
AMADA / WILA - BYSTRONIC

CODE	H	T/Mt	Mt
60.920	60.00	100	■

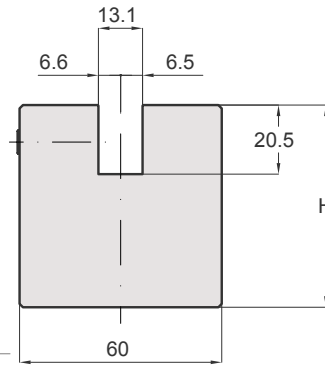
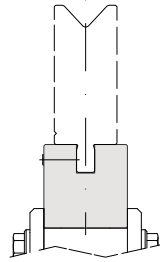

- 50 mm
- 100 mm
- 200 mm
- 300 mm
- 500 mm
- 1000 mm

ADATTATORE INFERIORE - LOWER ADAPTER
AMADA / WILA - BYSTRONIC

CODE	H	T/Mt	Mt
60.935	30.00	100	■

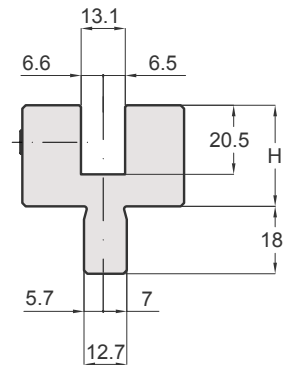
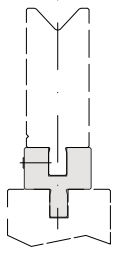

- 50 mm
- 100 mm
- 200 mm
- 300 mm
- 500 mm
- 1000 mm

ADATTATORE INFERIORE - LOWER ADAPTER
LVD / WILA - BYSTRONIC

CODE	L	H	T/Mt	Mt
60.940	500	40.00	100	■

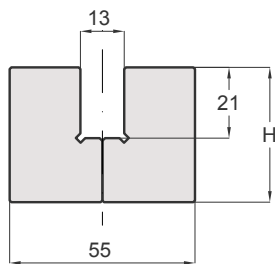
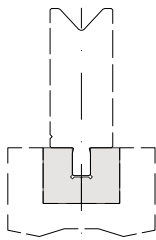

ADATTATORE INFERIORE - LOWER ADAPTER
EHT / WILA

CODE	L	H	T/Mt	Mt
60.950	500	45.00	100	■

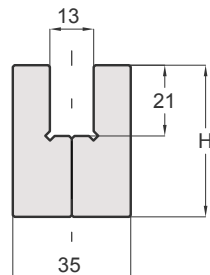
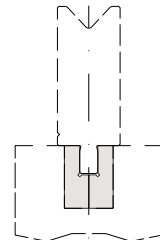

ADATTATORE INFERIORE - LOWER ADAPTER
WEINBRENNER / WILA



SUPPORTI E MATRICI A RULLI / ADAPTERS AND ROLLER DIES

CODE	α	H	T/Mt	Mt
20.720	80°	170.00	200	■

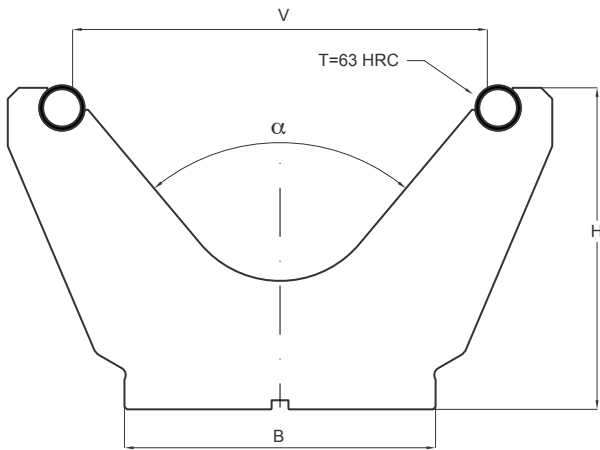

100 mm

LEGENDA	α = ANGOLO	B = BASE	V = AMPIEZZA CAVA	T = TEMPRAD INDUZIONE
LEGEND	α = ANGLE	B = WIDTH	V = DIE OPENING	T = INDUCTION HARDENING

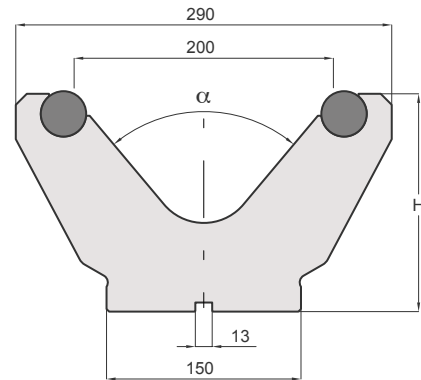

100 mm

CODE	α	H	T/Mt	Mt
20.725	80°	200.00	200	■

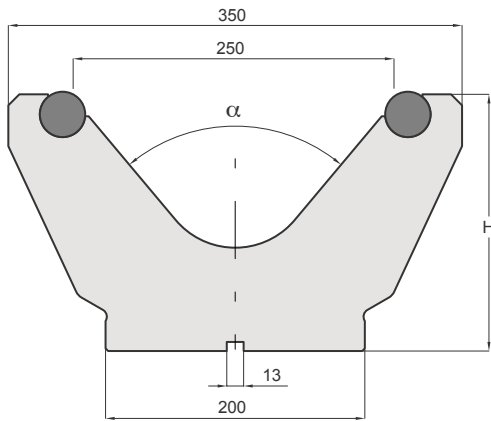

100 mm

CODE	α	H	T/Mt	Mt
20.732	80°	250.00	200	■

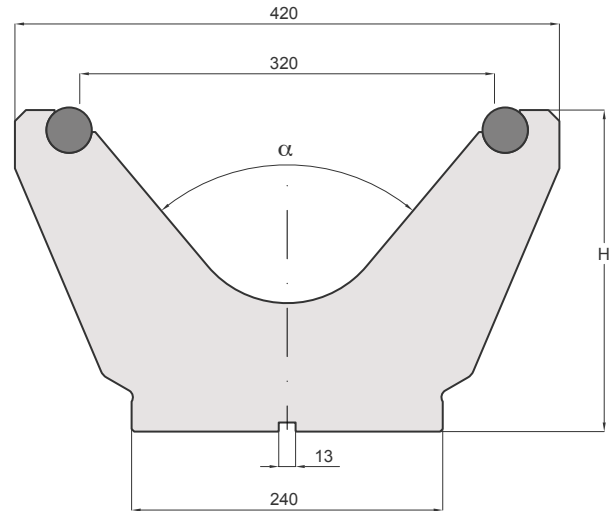

100 mm

CODE	L
20.701	100

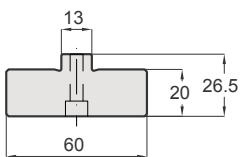

AMADA

CODE	L
20.707	100

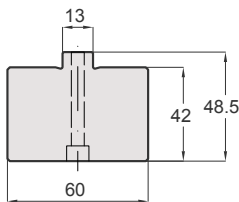

EHT

CODE	L
20.709	100

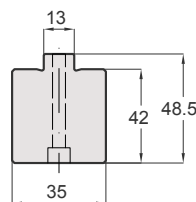

WEINBRENNER

CODE	L
20.705	100

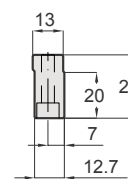

LVD

CODE	L
20.703	100

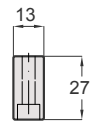

WILA - BYSTRONIC

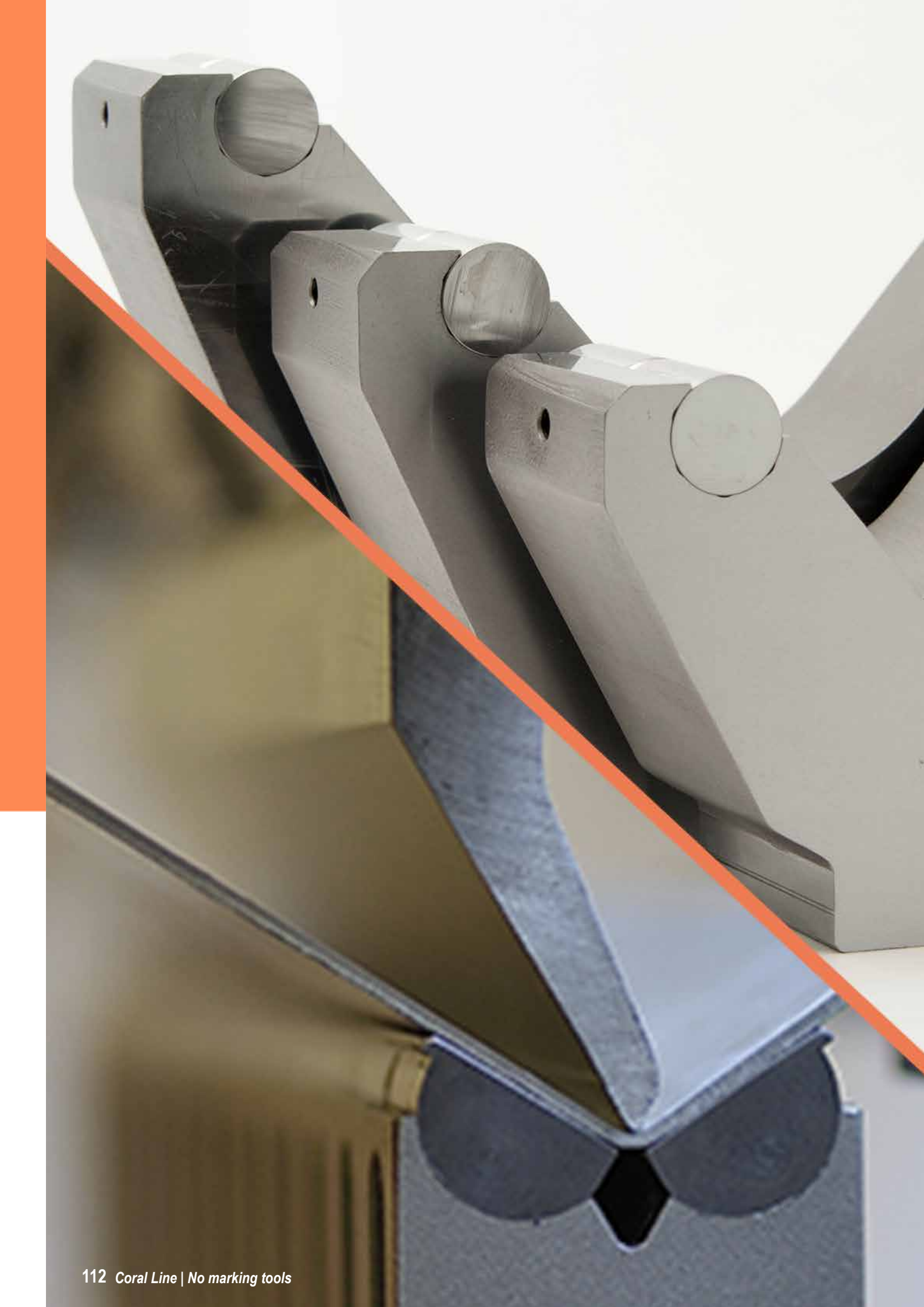

CONTENITORI E INSERTI IN POLIURETANO / HOLDERS AND POLYURETHANE INSERTS



CUSCINI IN POLIURETANO PIENI E FORATI CON RELATIVI CONTENITORI

VANTAGGI :

EVITANO I SEGNI DI PIEGATURA
 IDEALE PER PIEGARE ALLUMINIO, INOX E LAMIERE PREVERNICIATE
 ADATTI A PIEGHE A V , RAGGIATE E A FORMA DI U

POLYURETHANE INSERTS AND HOLDERS

ADVANTAGES :

AVOIDS MARKS ON BENDED SHEETS
 IDEAL FOR BENDING ALUMINIUM, STAINLESS STEEL AND PAINTED
 SURFACES

SUITABLE FOR V, RADIUS AND U-BENDING

CODE	H
21.280	26.00

415 mm
835 mm

INSERTO IN GOMMA PER MATRICE COD. 21.207
 POLYURETHANE INSERT FOR DIE COD. 21.207

CODE	H
20.271	60.00

415 mm
835 mm

CODE	H
20.272	96.00

415 mm
835 mm

CODE	H
20.273	100.00

415 mm
835 mm

CODE	H
20.274	100.00

415 mm
835 mm

CODE	H
20.292	25.00

415 mm
835 mm

CODE	H
20.291	50.00

415 mm
835 mm

CODE	H
20.290	50.00

415 mm
835 mm

CODE	H
20.289	50.00

415 mm
835 mm

CODE	H
21.292	25.00

415 mm
835 mm

CODE	H
21.291	50.00

415 mm
835 mm

CODE	H
21.290	50.00

415 mm
835 mm

CODE	H
21.289	50.00

415 mm
835 mm

CONTENITORI E INSERTI IN NYLON / NYLON INSERTS AND HOLDERS

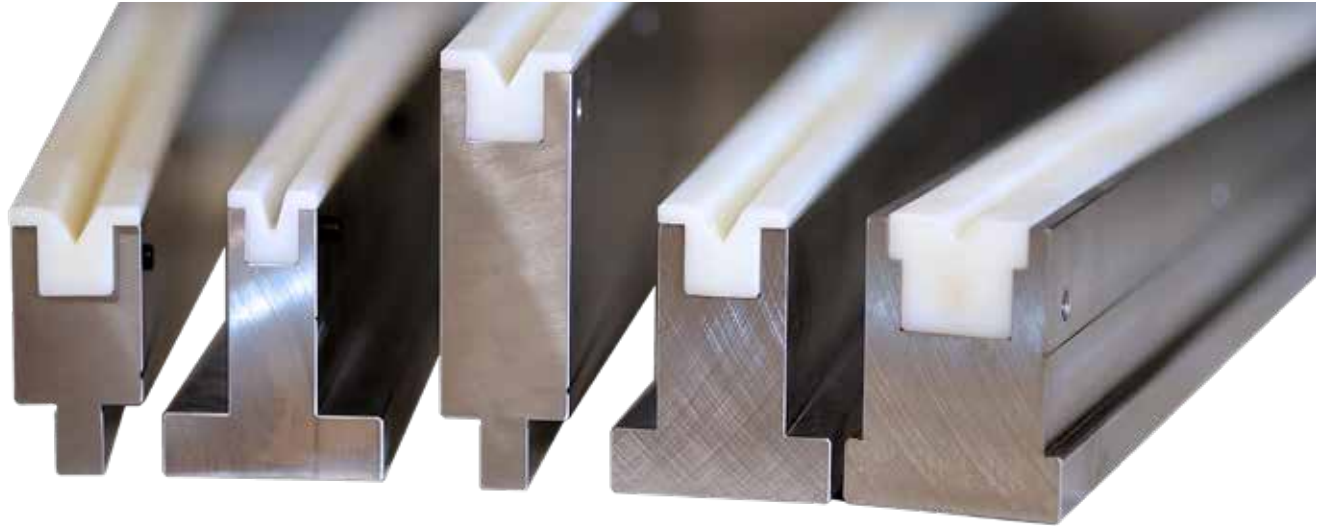

INSERTI IN NYLON E RELATIVI CONTENITORI

VANTAGGI :

- EVITANO I SEGNI DI PIEGATURA
- IDEALE PER PIEGARE ALLUMINIO, INOX E LAMIERE PREVERNICIATE
- CAMBIO FACILE E VELOCE

NYLON INSERTS AND HOLDERS

ADVANTAGES :

- AVOIDS MARKS ON BENDED SHEETS
- IDEAL FOR BENDING ALUMINIUM, STAINLESS STEEL AND PAINTED SURFACES
- FAST AND EASY CHANGE

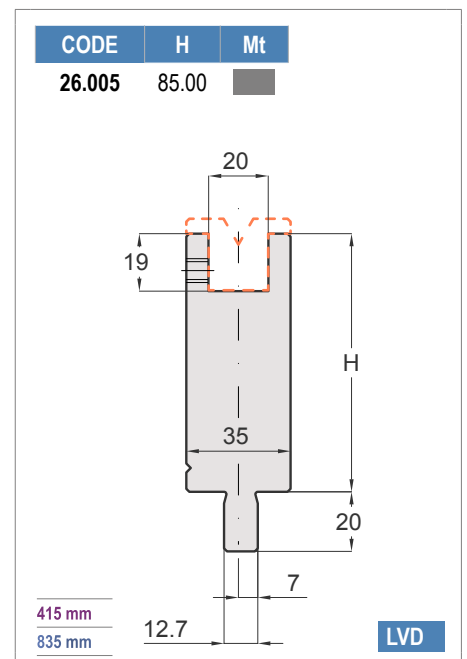
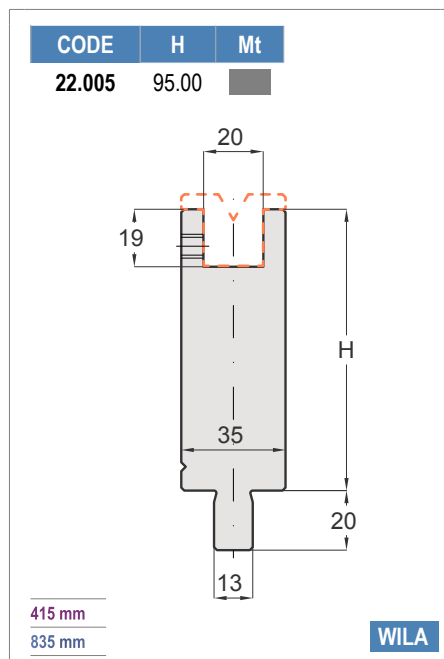
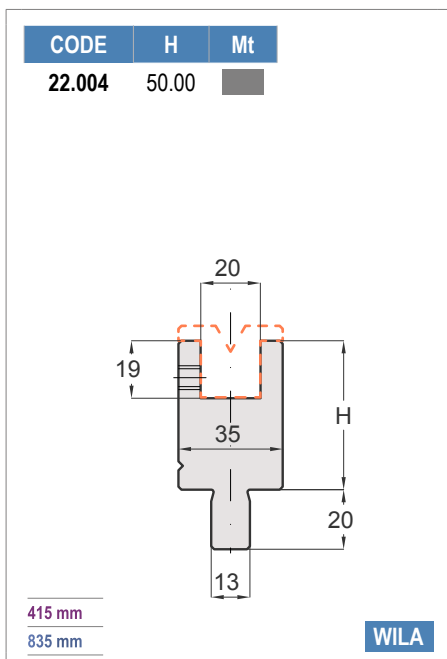
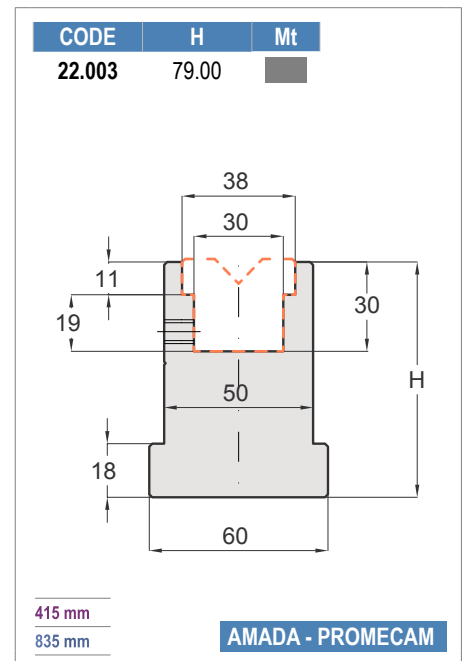
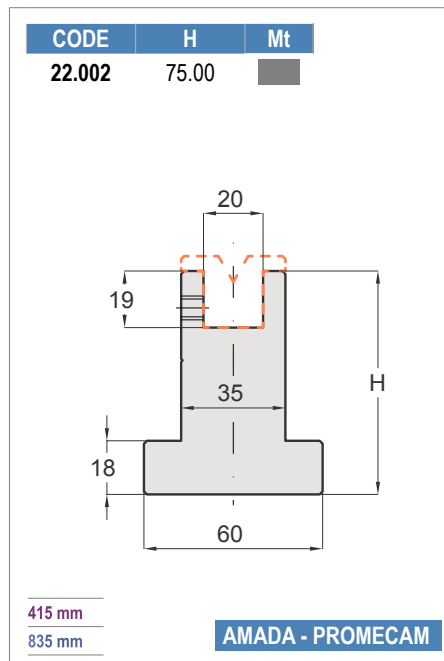
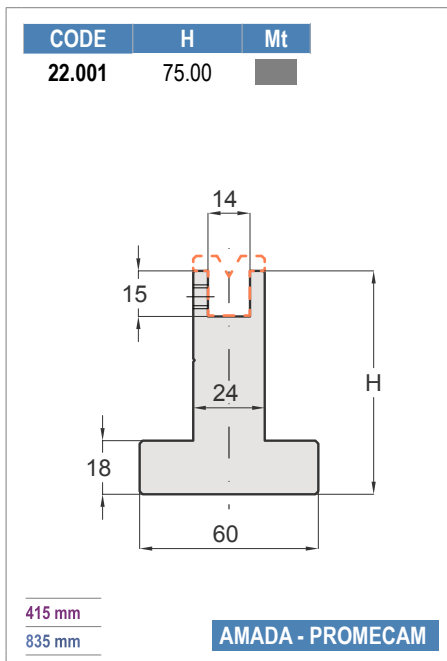

INSERTI IN NYLON / NYLON INSERTS

CODE	α	V	T/mt
31.306	30°	6	20
31.308	30°	8	20
31.406	45°	6	20
31.408	45°	8	20
31.410	45°	10	20
31.606	60°	6	20
31.608	60°	8	20
31.610	60°	10	20
31.806	88°	6	20
31.808	88°	8	20
31.810	88°	10	20

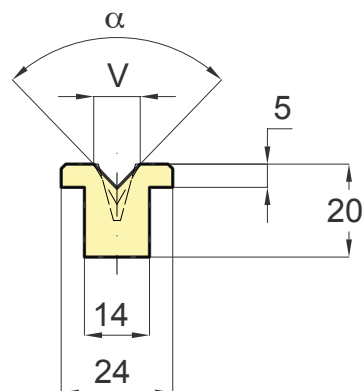

415 mm
835 mm

CODE	α	V	T/mt
32.306	30°	6	20
32.308	30°	8	20
32.310	30°	10	20
32.406	45°	6	20
32.408	45°	8	20
32.410	45°	10	20
32.412	45°	12	20
32.606	60°	6	20
32.608	60°	8	20
32.610	60°	10	20

CODE	α	V	T/mt
32.612	60°	12	20
32.616	60°	16	20
32.806	88°	6	20
32.808	88°	8	20
32.810	88°	10	20
32.812	88°	12	20
32.816	88°	16	20

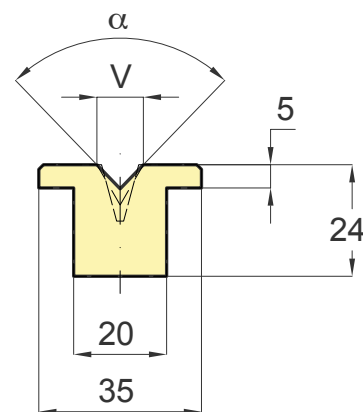

415 mm
835 mm

CODE	α	V	T/mt
33.306	30°	6	20
33.308	30°	8	20
33.310	30°	10	20
33.312	30°	12	20
33.316	30°	16	20
33.406	45°	6	20
33.408	45°	8	20
33.410	45°	10	20
33.412	45°	12	20
33.416	45°	16	20
33.420	45°	20	20
33.606	60°	6	20

CODE	α	V	T/mt
33.608	60°	8	20
33.610	60°	10	20
33.612	60°	12	20
33.616	60°	16	20
33.620	60°	20	20
33.806	88°	6	20
33.808	88°	8	20
33.810	88°	10	20
33.812	88°	12	20
33.816	88°	16	20
33.820	88°	20	20
33.825	88°	25	20

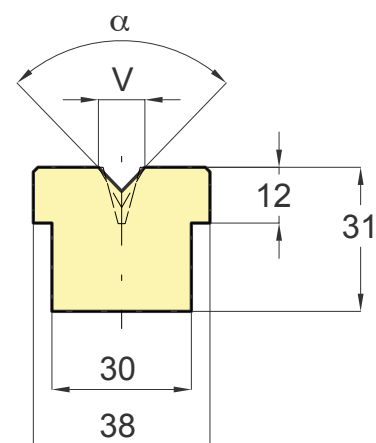

415 mm
835 mm

PELLICOLE ANTIGRAFFIO IN POLIURETANO / FILM OF POLYURETHANE ANTISCRATCH



CODE	S	L
40.810	0.8	95

THICKNESS $S=0.8$

95

LENGHT | 33 mt

LEGEND S = THICKNESS L = WIDTH

CODE	S	L
40.815	0.3	95

THICKNESS $S=0.3$

95

LENGHT | 33 mt

CODE	S	L
40.820	0.5	95

THICKNESS $S=0.5$

95

LENGHT | 33 mt

CODE	S	L
40.830	0.5	35

THICKNESS $S=0.5$

35

LENGHT | 33 mt

CODE	S	L
40.835	1.5	200

THICKNESS $S=1.5$

200

LENGHT | 15 mt

CODE	S	L
40.840	0.5	150

THICKNESS $S=0.5$

150

LENGHT | 33 mt

CODE	S	L
40.845	2	250

THICKNESS $S=2$

250

LENGHT | 10 mt

TENDIPELLICOLA STANDARD E MAGNETICO / STANDARD AND MAGNETIC FILM HOLDER

CODE

40.800

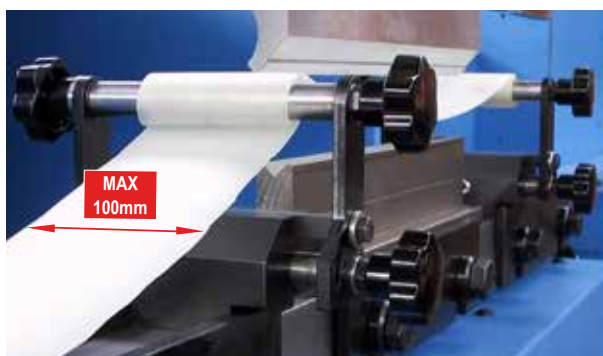

STANDARD SYSTEM

Max = 100mm

CODE

40.850

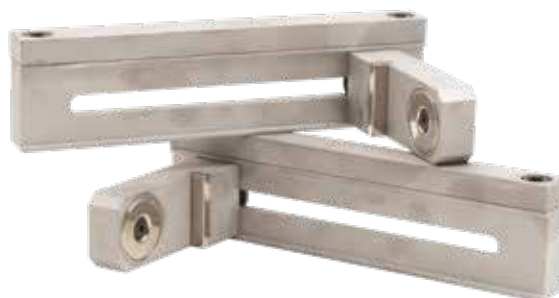

MAGNETIC SYSTEM

Max = 150mm

CODE

40.860

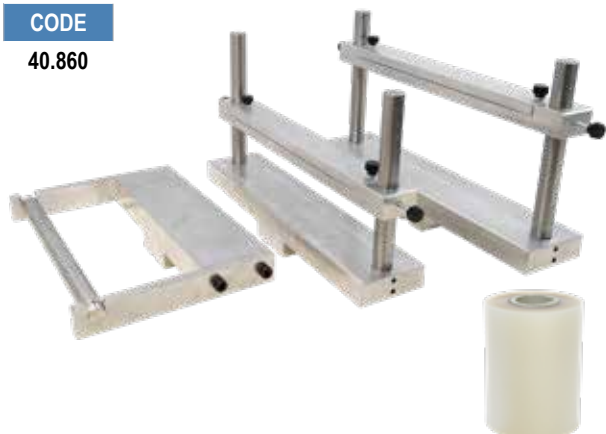

STANDARD SYSTEM

Max = 250mm

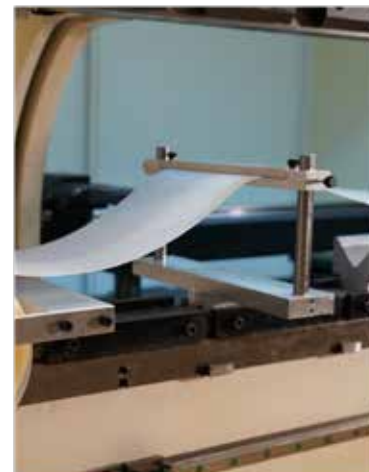

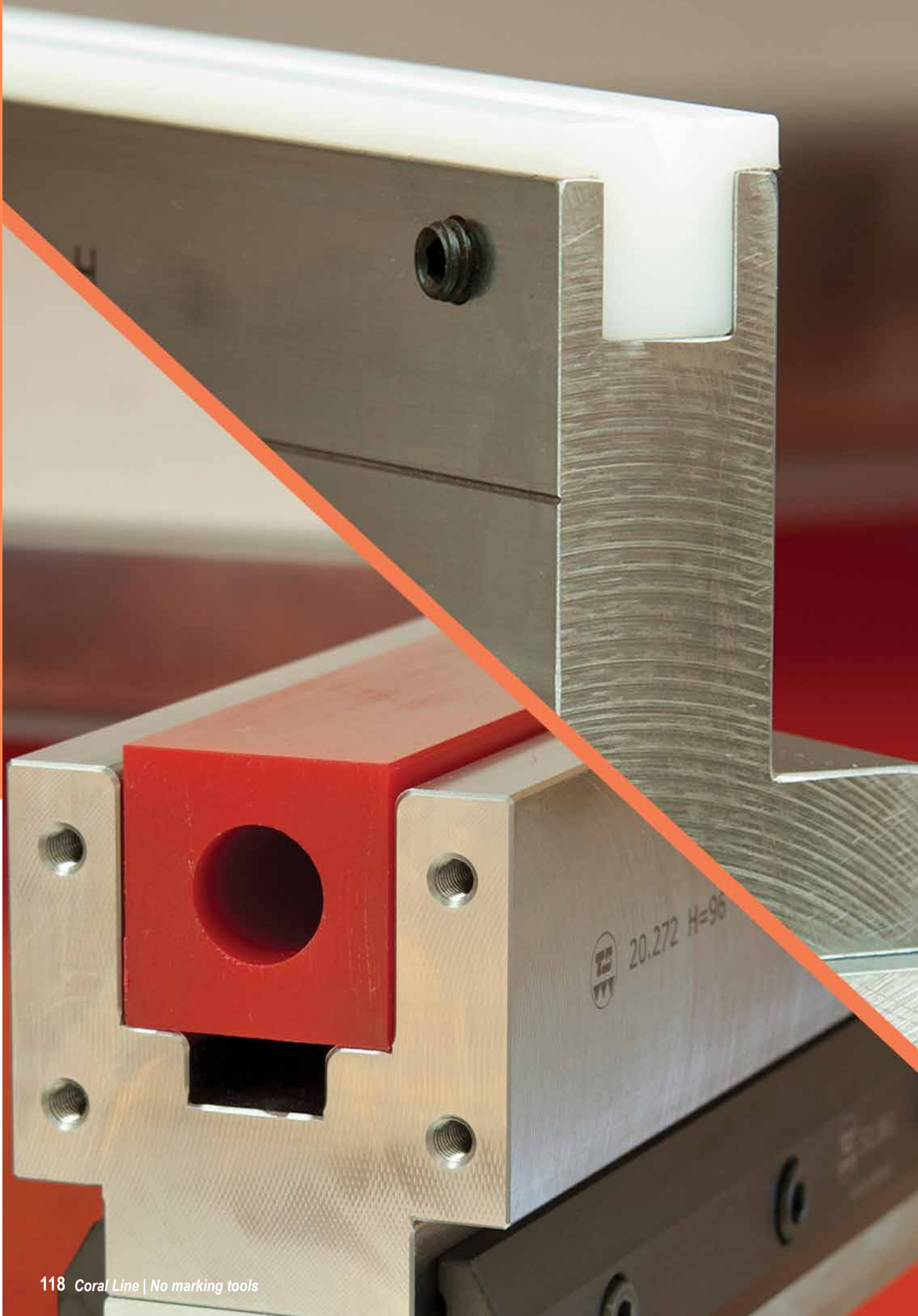

MAGENTA LINE

ADATTATORI
ADAPTERS

INTERMEDIARI
INTERMEDIATES

CANALINE
HOLDERS

INTERMEDIARIO RAPIDO MANUALE
MANUAL FAST CLAMPING

STAFFE
CLAMP PLATES

ADATTATORI INFERIORI
LOWER ADAPTERS

INTERMEDIARI PNEUMATICI
PNEUMATIC INTERMEDIATES



MAGENTA LINE

**ADATTATORI PER TUTTE LE PRESSE
ADAPTERS FOR ALL PRESS BRAKES**

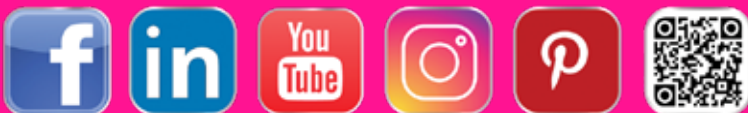

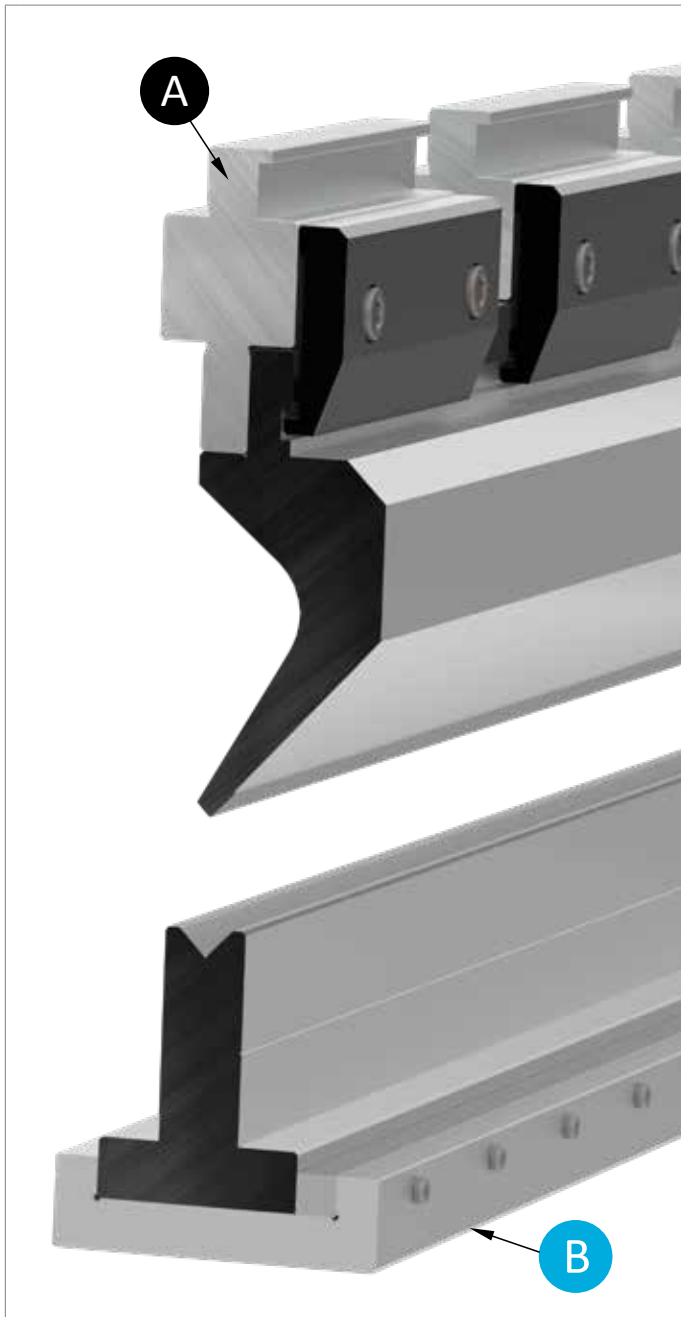

SPECIFICARE DIMENSIONE

SPECIFY DIMENSION

	1	2	Mt
A =			
B =			
C =			
D =			

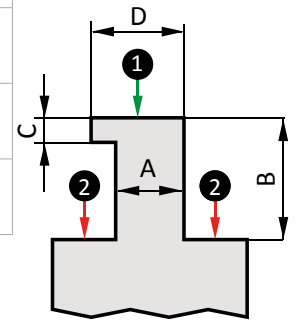

A

CODE	L	T/Mt	Mt
60.680	2100	100	■
60.681	2600	100	■
60.682	3100	100	■
60.683	4100	100	■

B

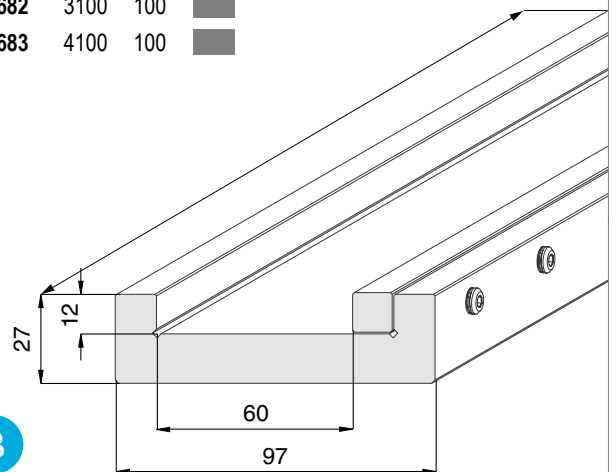

CODE	L	H	T/Mt	Mt
800.000	150	59.00	100	■

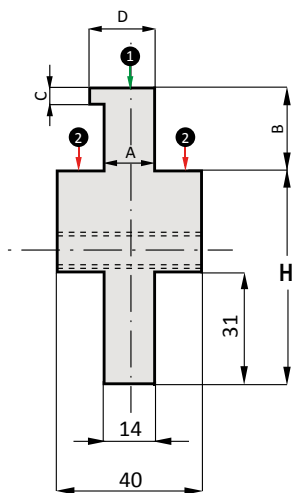

A

CODE	L	H	T/Mt	Mt
810.000	150	67.00	100	■

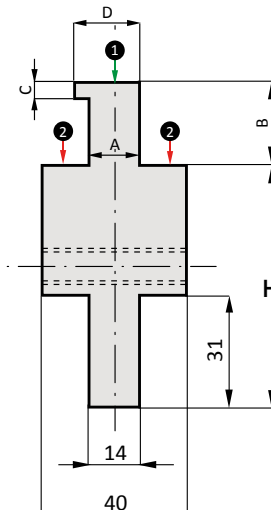

A

CODE	L	H	T/Mt	Mt
820.000	150	100.00	100	■

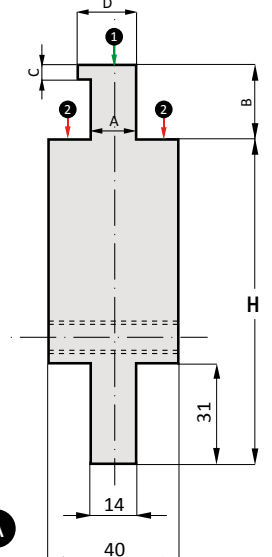

A

INTERMEDIARI REGISTRABILI / ADJUSTABLES INTERMEDIATES
STAFFE NON COMPRESSE / CLAMP PLATES NOT INCLUDED

AMADA - PROMECAM STYLE

CODE	L	H	T/Mt	Mt
50.666	150	100.00	100	
50.668	150	120.00	100	
50.512	150	150.00	100	

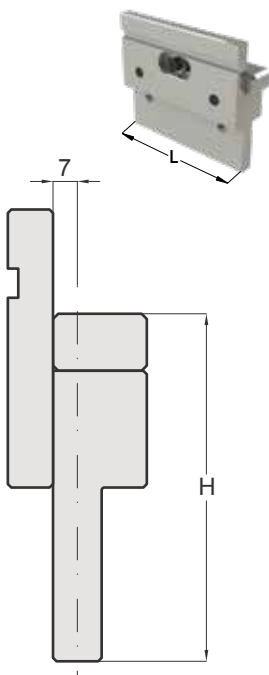

CODE	L	H	T/Mt	Mt
50.674	150	120.00	100	

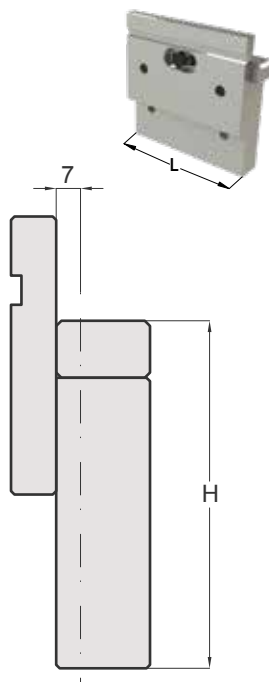

CODE	L	H	T/Mt	Mt
50.705	70	100.00	100	
50.706	70	120.00	100	
50.708	70	150.00	100	

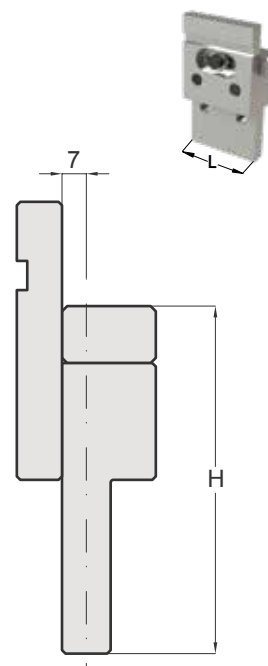

CODE	L	H	T/Mt	Mt
50.680	150	100.00	100	
50.667	150	120.00	100	
50.669	150	150.00	100	

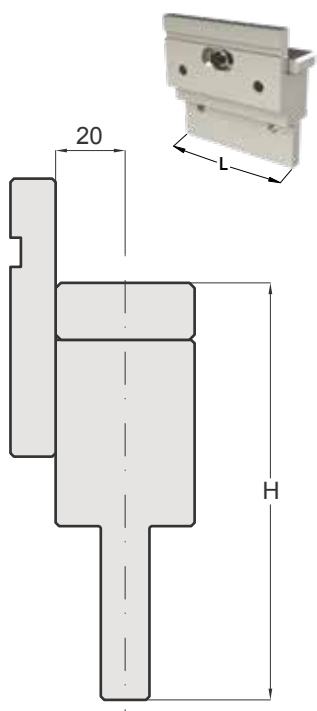

CODE	L	H	T/Mt	Mt
50.673	150	120.00	100	

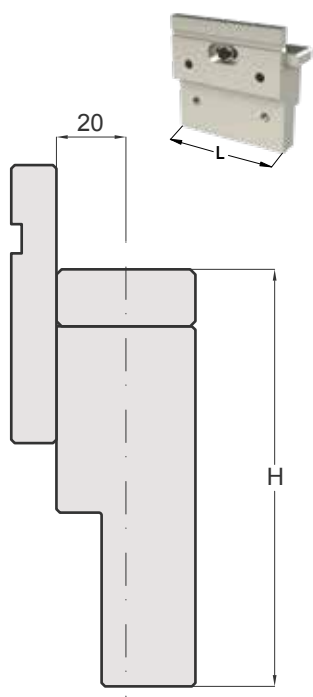

CODE	L	H	T/Mt	Mt
50.707	70	120.00	100	
50.710	70	150.00	100	

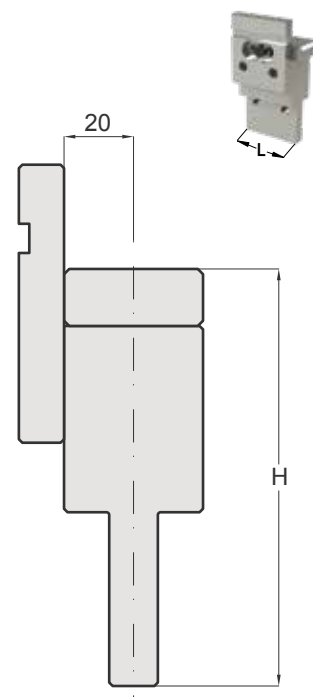

PROLUNGHE E ADATTATORI / EXTENSIONS AND ADAPTERS
STAFFE NON COMPRESI / CLAMP PLATES NOT INCLUDED

CODE	L	H	T/Mt	Mt
50.959	150	60.00	100	■

PROLUNGA
EXTENSION
AMADA

CODE	L	H	T/Mt	Mt
50.671	150	100.00	100	■

PROLUNGA
EXTENSION
AMADA

CODE	L	H	T/Mt	Mt
50.430	150	67.00	100	■

ADATTATORE
ADAPTER
AMADA / WILA

CODE	L	H	T/Mt	Mt
50.970	150	83.00	100	■

ADATTATORE
ADAPTER
WILA / AMADA

CODE	L	H	T/Mt	Mt
50.971	150	80.00	100	■

ADATTATORE
ADAPTER
WILA / AMADA

CODE	L	H	T/Mt	Mt
50.940	150	120.00	100	■

ADATTATORE
ADAPTER
WILA / AMADA

CODE	L	H	T/Mt	Mt
50.410	150	100.00	100	■
50.415	50	100.00	100	■

PROLUNGA
EXTENSION
WILA

CODE	L	H	T/Mt	Mt
50.440	150	150.00	100	■
50.445	50	150.00	100	■

PROLUNGA
EXTENSION
WILA

CODE	L	H	T/Mt	Mt
50.450	150	63.00	100	■

ADATTATORE
ADAPTER
EHT / WILA

PROLUNGHE E ADATTATORI / EXTENSIONS AND ADAPTERS
STAFFE NON COMPRESI / CLAMP PLATES NOT INCLUDED

CODE	L	H	T/Mt	Mt
50.470	150	65.00	100	■

ADATTATORE
ADAPTER

LVD / WILA

CODE	L	H	T/Mt	Mt
50.490	150	65.00	100	■

ADATTATORE
ADAPTER

WEINBRENNER / WILA

CODE	L	H	T/Mt	Mt
50.960	150	23.00	100	■

ADATTATORE
ADAPTER

USA / WILA

CODE	L	H	T/Mt	Mt
50.981	150	67.00	100	■

ADATTATORE
ADAPTER

BYSTRONIC-S / AMADA

CODE	L	H	T/Mt	Mt
50.980	150	67.00	100	■

ADATTATORE
ADAPTER

BYSTRONIC-R / AMADA

CODE	L	H	T/Mt	Mt
50.983	150	100.00	100	■

ADATTATORE
ADAPTER

BYSTRONIC RF-A / AMADA

CODE	L	H	T/Mt	Mt
50.985	150	100.00	100	■

PROLUNGA
EXTENSION

BYSTRONIC EURO

CODE	L	H	T/Mt	Mt
50.982	150	101.00	100	■

PROLUNGA
EXTENSION

BYSTRONIC - R

STAFFA INCLUSA
CLAMP PLATE INCLUDED

CODE	L	H	T/Mt	Mt
50.400	150	100.00	100	■

PROLUNGA
EXTENSION

BYSTRONIC RF-A

STAFFA INCLUSA
CLAMP PLATE INCLUDED

ADATTATORI / ADAPTERS

STAFFE NON COMPRESSE / CLAMP PLATES NOT INCLUDED

CODE	L	H	T/Mt	Mt
50.990	150	80.00	100	■

ADATTATORE
ADAPTER

LVD / AMADA

CODE	L	H	T/Mt	Mt
50.992	150	67.00	100	■

ADATTATORE
ADAPTER

DURMAZLAR / AMADA

CODE	L	H	T/Mt	Mt
50.994	150	100.00	100	■

ADATTATORE
ADAPTER

DARLEY / AMADA

CODE	L	H	T/Mt	Mt
50.997	150	67.00	100	■

ADATTATORE
ADAPTER

DARLEY / AMADA

CODE	L	H	T/Mt	Mt
50.996	150	89.00	100	■

ADATTATORE
ADAPTER

BAYKAL / AMADA

CODE	L	H	T/Mt	Mt
50.998	150	67.00	100	■

ADATTATORE
ADAPTER

HACO / AMADA

CODE	L	H	T/Mt	Mt
50.950	150	67.00	100	■

ADATTATORE
ADAPTER

USA / AMADA

CODE	L	H	T/Mt	Mt
50.991	150	100.00	100	■

ADATTATORE
ADAPTER

EHT / AMADA

CODE	L	H	T/Mt	Mt
50.993	150	100.00	100	■

ADATTATORE
ADAPTER

WEINBRENNER / AMADA

PROLUNGHE E ADATTATORI / EXTENSIONS AND ADAPTERS
STAFFE INCLUSE / CLAMP PLATES INCLUDED

CODE	L	H	T/Mt	Mt
50.930	150	100.00	100	■

ADATTATORE
 ADAPTER
NEWTON / AMADA

CODE	L	H	T/Mt	Mt
50.935	150	100.00	100	■

ADATTATORE
 ADAPTER
AMADA / NEWTON

CODE	L	H	T/Mt	Mt
50.500	200	220.00	90	■

PROLUNGA
 EXTENSION
AMADA

CODE	L	H	T/Mt	Mt
50.501	200	220.00	90	■

PROLUNGA
 EXTENSION
AMADA

PROLUNGHE E ADATTATORI / EXTENSIONS AND ADAPTERS
STAFFE INCLUSE / CLAMP PLATES INCLUDED

CODE	L	H	T/Mt	Mt
50.502	200	220.00	90	■

ADATTATORE
 ADAPTER
 WILA / AMADA

CODE	L	H	T/Mt	Mt
50.503	200	220.00	90	■

PROLUNGA
 EXTENSION
 WILA

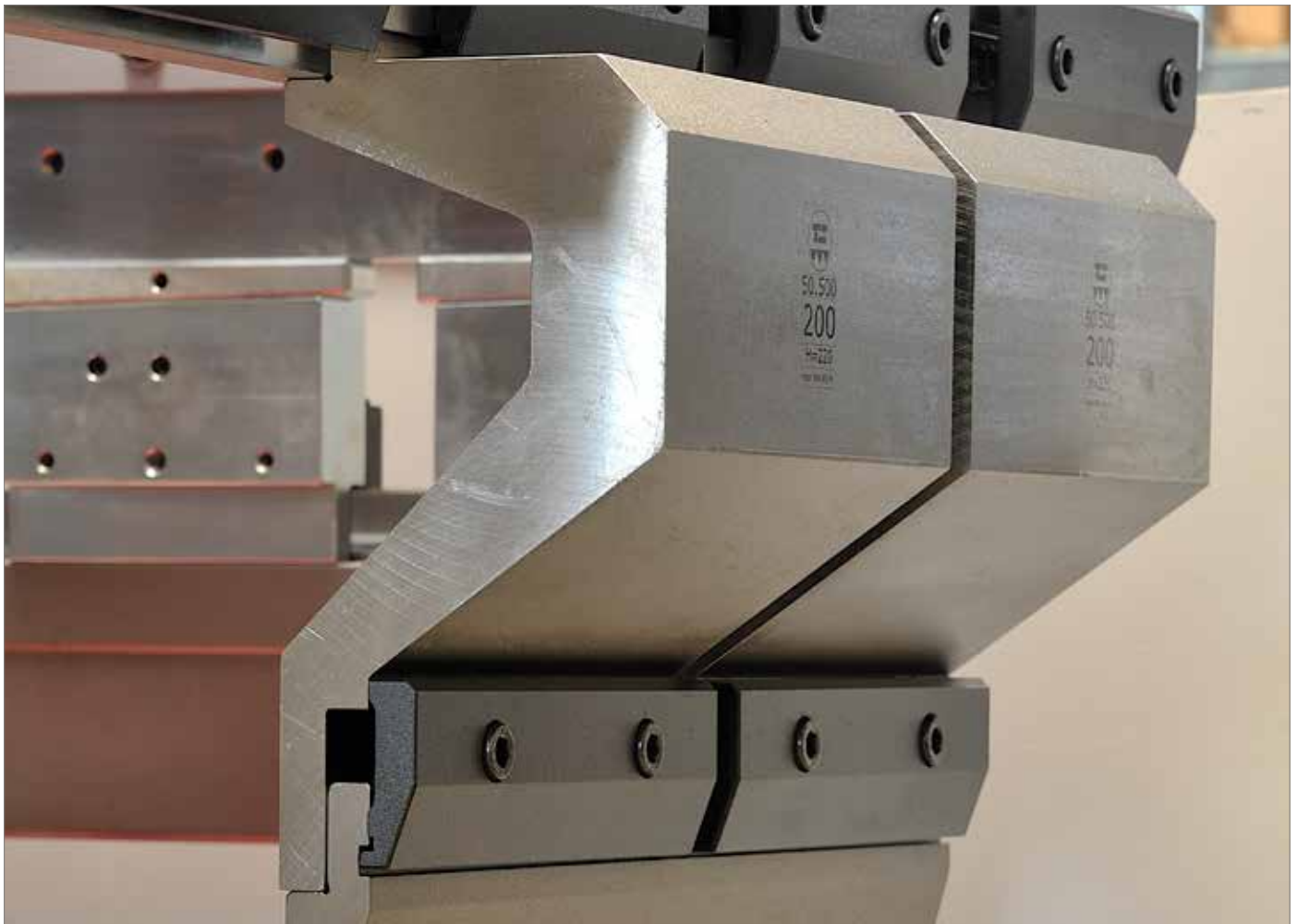

CODE	L	H	T/Mt	Mt
50.200	150	100.00	100	■
50.210	150	120.00	100	■
50.220	150	150.00	100	■

AMADA - PROMECAM

CODE	L	H	T/Mt	Mt
50.250	150	150.00	100	■

AMADA - PROMECAM

CODE	L	H	T/Mt	Mt
50.972	150	105.00	100	■

WILA / AMADA

CODE	L	H	T/Mt	Mt
50.945	150	120.00	100	■

WILA / AMADA

STAFFE REGISTRABILI E FISSE / CLAMP PLATES FOR ADAPTERS

CODE	L	H
50.529	150	50.00

STAFFA
CLAMP PLATE

CODE	L	H
50.571	150	60.00

STAFFA DI SICUREZZA
SAFETY CLAMP PLATE

CODE	L	H
50.551	150	60.00

STAFFA DI SICUREZZA RAPIDA CON LEVETTA
QUICK SAFETY CLAMP PLATE

CODE	L	H
50.900	150	60.00

STAFFA DI SICUREZZA CON LEVETTA A SCOMPARSA
QUICK CLAMP PLATE WITH FOLDAWAY LEVER

CODE	L	H
50.910	150	60.00

STAFFA CON INSERTO IN POLIURETANO PER FRAZIONATI
CLAMP WITH POLYURETHANE FOR SECTIONED TOP TOOLS

CODE	L	H
50.905	150	60.00

STAFFA RAPIDA CON INSERTO IN POLIURETANO PER FRAZIONATI
QUICK CLAMP WITH POLYURETHANE FOR SECTIONED TOP TOOLS

CODE	L	H
50.903	150	60.00

STAFFA CON LEVETTA A SCOMPARSA ED INSERTO IN POLIURETANO
QUICK CLAMP WITH FOLDAWAY LEVER AND POLYURETHANE

TCEI M10X70	71.100	TCEI M10X35
CODE		
50.574	50.551	50.529
50.577	50.905	50.571
		50.900
		50.910
		50.903
		50.310
		50.712
		50.697
		50.693



STAFFE FISSE / CLAMP PLATES FOR ADAPTERS

CODE	L	H
50.310	150	45.00

STAFFA
CLAMP PLATE

CODE	L	H
50.712	150	52.00

STAFFA DI SICUREZZA
SAFETY CLAMP PLATE

CODE	L	H
50.697	70	50.00

STAFFA
CLAMP PLATE

CODE	L	H
50.693	70	60.00

STAFFA DI SICUREZZA
SAFETY CLAMP PLATE

KIT PER DOPPIO STAFFAGGIO / EQUIPMENT FOR DOUBLE CLAMPING PLATE

CODE
50.574

KIT PER DOPPIO STAFFAGGIO
EQUIPMENT FOR DOUBLE CLAMPING PLATE

CODE
50.577

KIT PER DOPPIO STAFFAGGIO
EQUIPMENT FOR DOUBLE CLAMPING PLATE

ADATTATORI INFERIORI / LOWER ADAPTERS

CODE	H	T/Mt	Mt
60.910	30.00	100	

50 mm
100 mm
200 mm
300 mm
500 mm
1000 mm

ADATTATORE INFERIORE
LOWER ADAPTER

AMADA / WILA - BYSTRONIC

CODE	H	T/Mt	Mt
60.920	60.00	100	

50 mm
100 mm
200 mm
300 mm
500 mm
1000 mm

ADATTATORE INFERIORE
LOWER ADAPTER

AMADA / WILA - BYSTRONIC

CODE	H	T/Mt	Mt
60.925	40.00	100	

415 mm
835 mm

ADATTATORE INFERIORE
LOWER ADAPTER

WILA - BYSTRONIC / AMADA

CODE	H	T/Mt	Mt
60.935	30.00	100	

50 mm
100 mm
200 mm
300 mm
500 mm
1000 mm

ADATTATORE INFERIORE
LOWER ADAPTER

LVD / WILA - BYSTRONIC

CODE	L	H	T/Mt	Mt
60.940	500	40.00	100	

ADATTATORE INFERIORE
LOWER ADAPTER

EHT / WILA

CODE	L	H	T/Mt	Mt
60.950	500	45.00	100	

ADATTATORE INFERIORE
LOWER ADAPTER

WEINBRENNER / WILA

CODE	H	T/Mt	Mt
60.930	40.00	100	

415 mm
835 mm

ADATTATORE INFERIORE
LOWER ADAPTER

LVD / AMADA

CODE	H	T/Mt	Mt
60.919	55.00	100	

415 mm
835 mm

PROLUNGA
EXTENSION

AMADA - PROMECAM

CODE	L	H	T/Mt	Mt
60.960	500	50.00	100	

ADATTATORE INFERIORE
LOWER ADAPTER

WILA

ADATTATORI INFERIORI / LOWER ADAPTERS

CODE	L	H	T/Mt	Mt
60.965	500	85.00	100	■

PROLUNGA
EXTENSION

WILA

CODE	H	T/Mt	Mt
60.980	35.00	100	■

415 mm
835 mm

ADATTATORE INFERIORE
LOWER ADAPTER

USA / EU - WILA - AMADA

CODE	H	T/Mt	Mt
60.945	60.00	100	■

415 mm
835 mm

ADATTATORE INFERIORE
LOWER ADAPTER

EHT / AMADA

CODE	H	T/Mt	Mt
60.955	65.00	100	■

415 mm
835 mm

ADATTATORE INFERIORE
LOWER ADAPTER

WEINBRENNER / AMADA

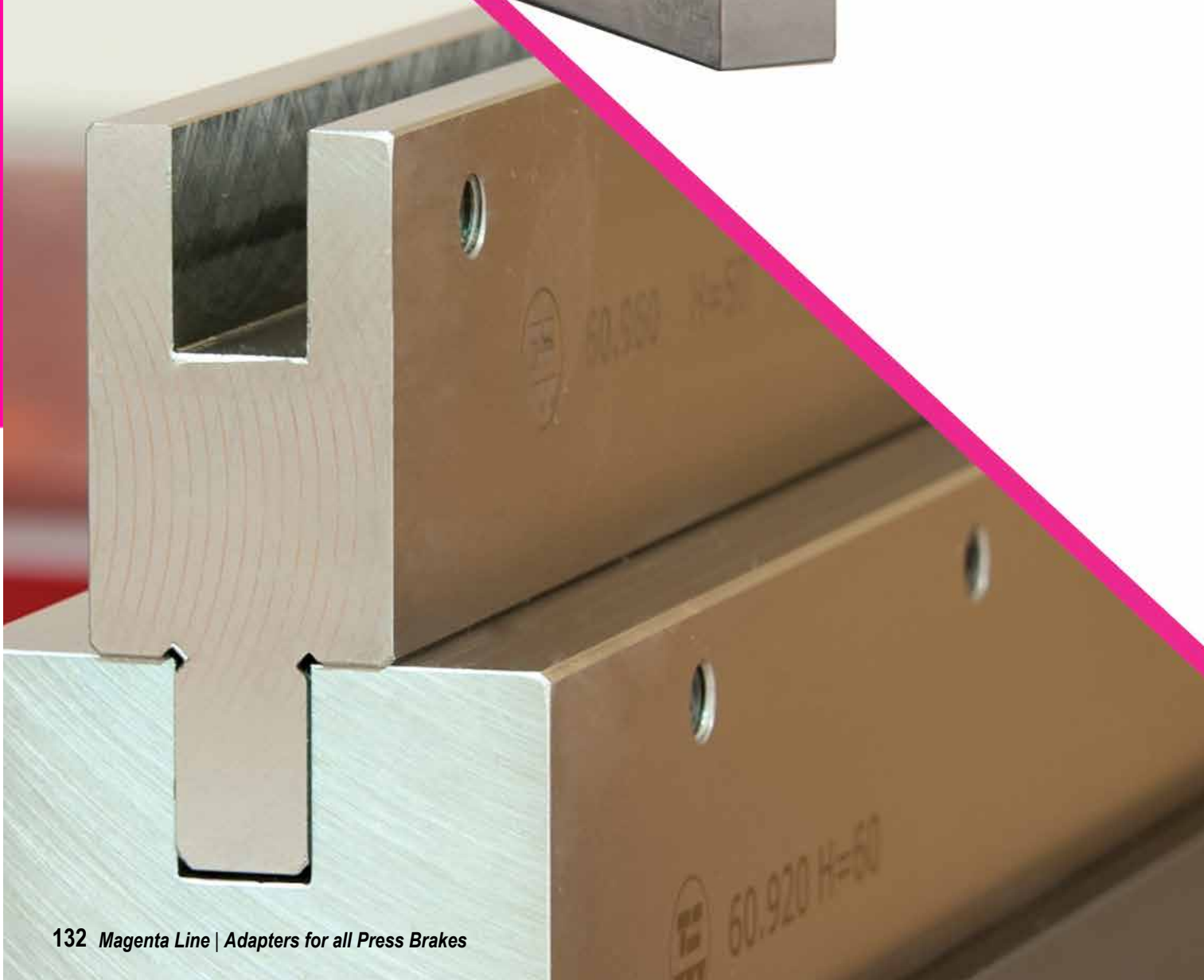

CANALINA MODULARE / MODULAR HOLDERS

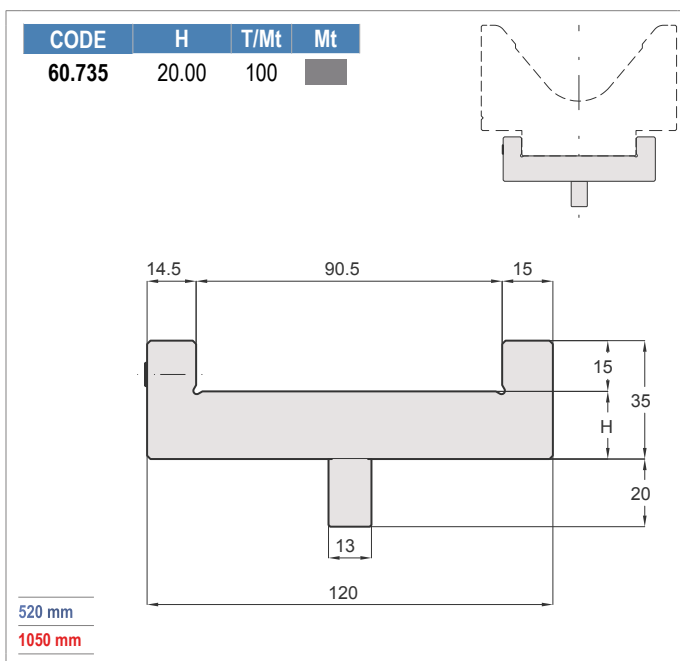
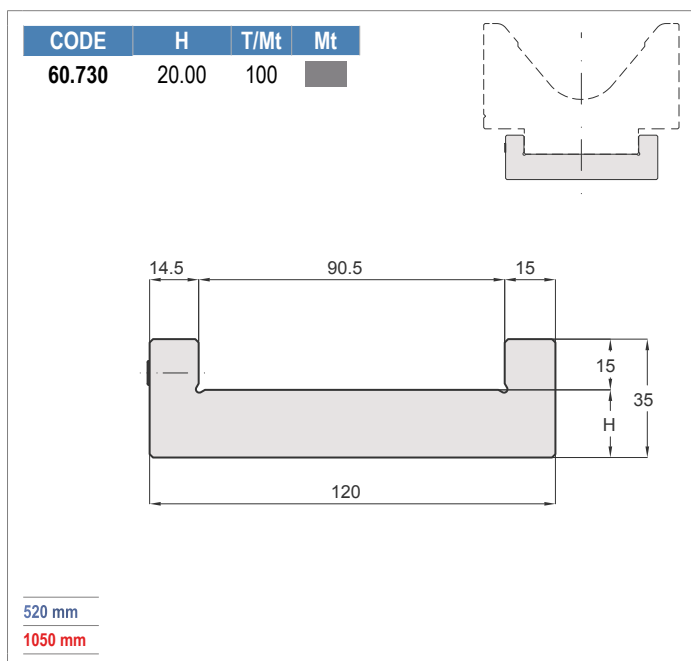
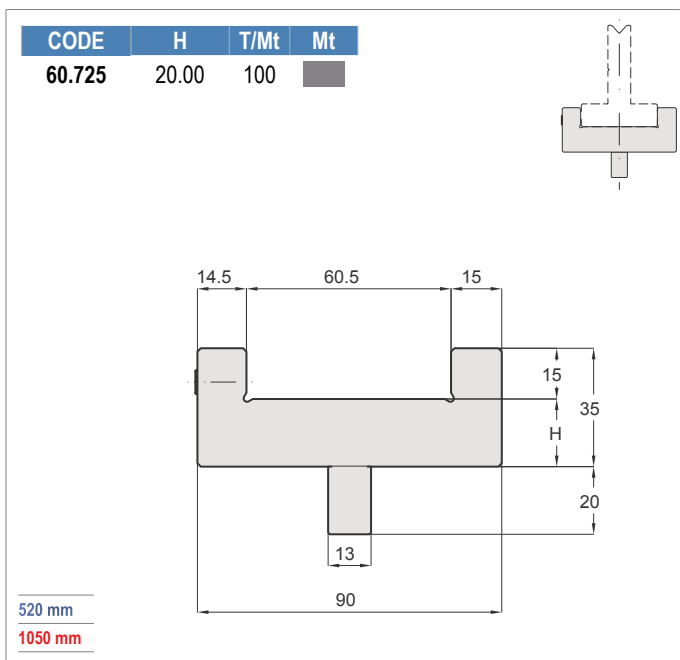
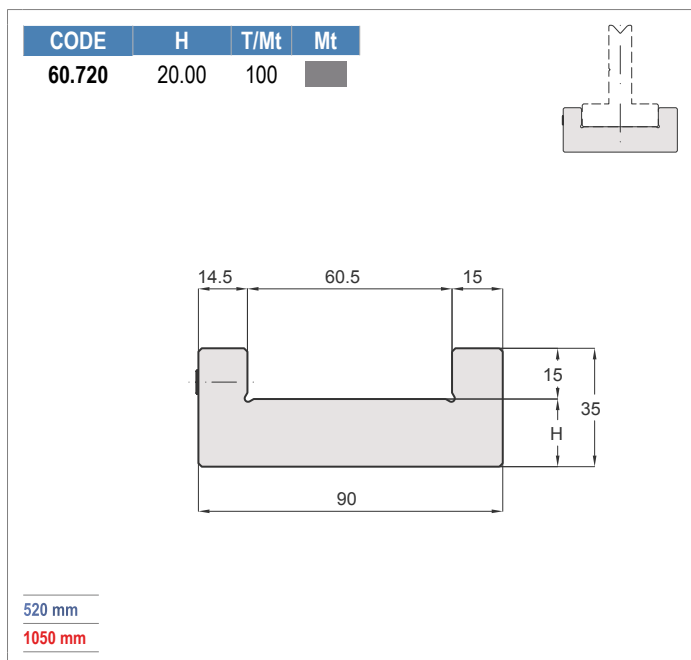
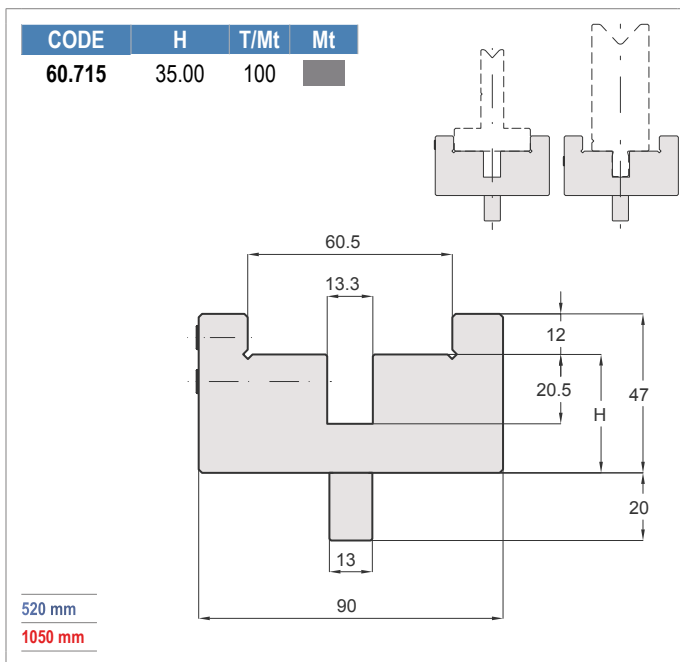
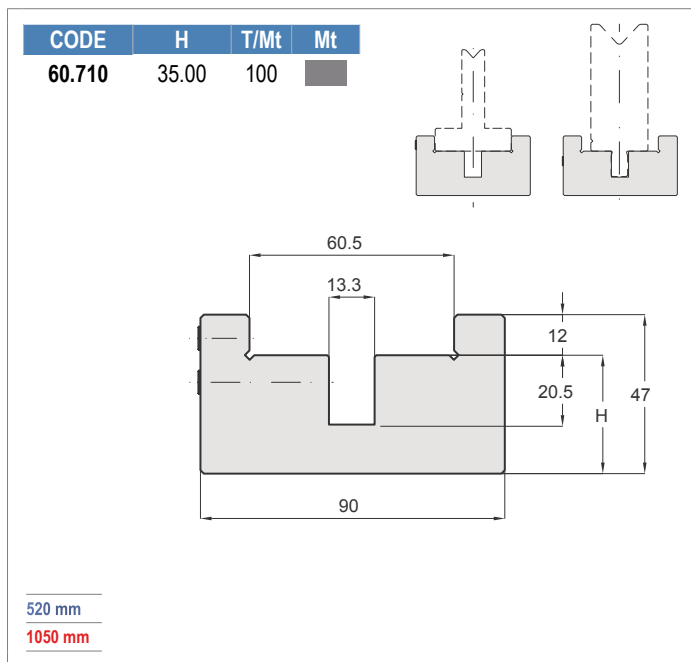

RAPID MONTAGGIO LATERALE / SIDE INSTALLATION

SERIE "RAPID" - PER UTENSILI SUPERIORI CON SCANALATURA AMADA 8.4X3mm (70.946)

"RAPID" SERIES - FOR UPPER TOOLS ONLY WITH AMADA SAFETY GROOVE 8.4X3mm (70.946)

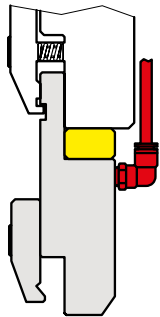

RAPID

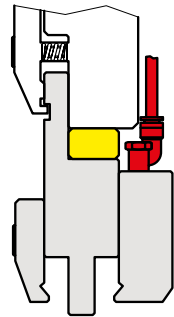

RAPID REVERS.

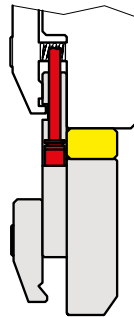

RAPID "FP"

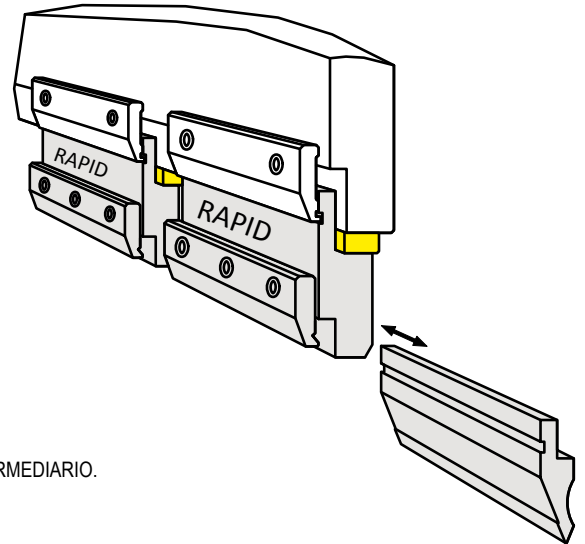

INTERMEDIARIO PNEUMATICO CENTINABILE.
 BLOCCAGGIO PNEUMATICO/SBLOCCAGGIO MECCANICO.
 MONTAGGIO E SMONTAGGIO LATERALE DEGLI UTENSILI.
 L'UTENSILE VIENE PORTATO AUTOMATICAMENTE IN BATTUTA CONTRO IL CORPO DELL'INTERMEDIARIO.
 TUBI DI COLLEGAMENTO AD INNESTO RAPIDO COMMERCIALI.

ADJUSTABLE PNEUMATIC ADAPTER.

PNEUMATIC CLAMPING/MECHANICAL UNCLAMPING.

SIDE INSTALLATION/DISINSTALLATION OF TOOLS.

THE TOOLS ARE AUTOMATICALLY POSITIONED AND CENTERED.

FAST COUPLING CONNECTIONS AND ITS JOINING PIPES AVAILABLE ON THE MARKET.

APERTO
OPEN

CORSA = 1mm
STROKE = 1 mm

Scanalatura di sicurezza standard 8.4x3 (AMADA)
Standard safety groove 8.4x3 (AMADA)

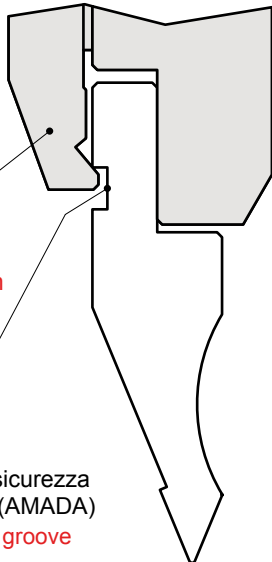

CHIUSO
CLOSED

FORZA DI BLOCCAGGIO A 10 BAR=700 kg
CLAMPING POWER AT 10 BARS = 700 Kg

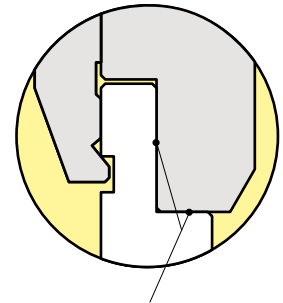

Punzone automaticamente posizionato e centrato.
Tool automatically positioned and centered.

CENTRALINA PNEUMATICA
PNEUMATIC EQUIPMENT

50.650
A 1 COMANDO
ONE CONTROL

50.651
A 2 COMANDI
TWO CONTROLS

CODE	A	H	T/Mt	Mt
50.800	7	100.00	100	■
50.805	7	120.00	100	■
50.810	7	150.00	100	■

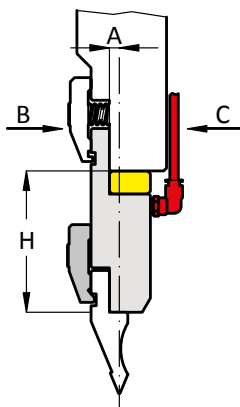

RAPID

CODE	A	H	T/Mt	Mt
50.870	7	100.00	100	■
50.875	7	150.00	100	■
50.890	20	120.00	100	■

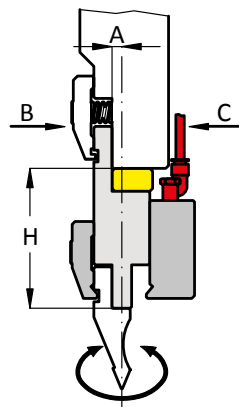

RAPID REVERSIBLE

CODE	A	H	T/Mt	Mt
50.820	7	100.00	100	■
50.825	7	150.00	100	■
50.830	20	120.00	100	■
50.835	20	150.00	100	■

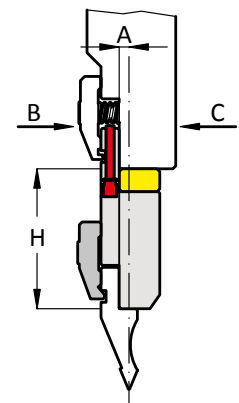

RAPID "FP"

CLARK MONTAGGIO FRONTALE / FRONT INSTALLATION

SERIE "CLARK" - PER UTENSILI SUPERIORI CON SCANALATURA DI SICUREZZA DOPPIA (70.1050)

"CLARK" SERIES - FOR UPPER TOOLS ONLY WITH DOUBLE SAFETY GROOVE (70.1050)

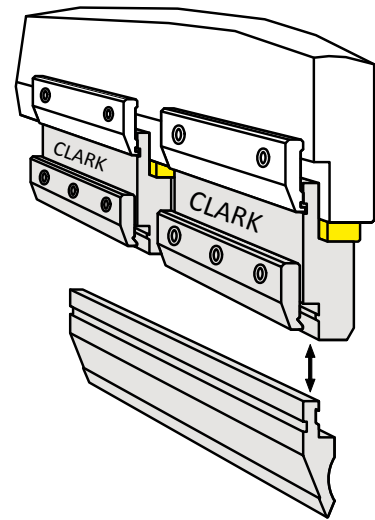
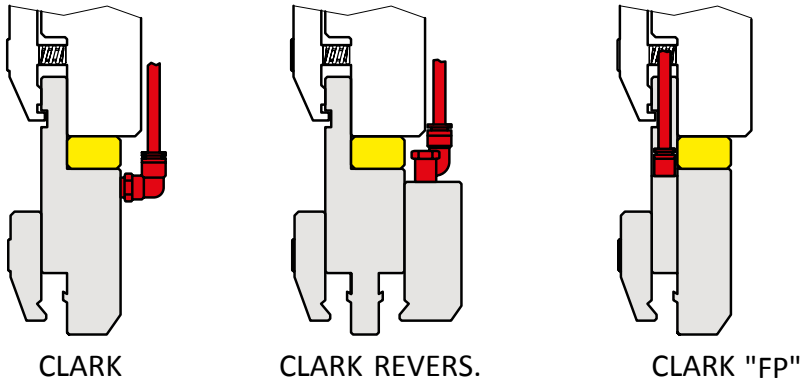

INTERMEDIARIO PNEUMATICO CENTINABILE.
 BLOCCAGGIO PNEUMATICO/SBLOCCAGGIO MECCANICO.
 MONTAGGIO E SMONTAGGIO FRONTALE DEGLI UTENSILI.
 L'UTENSILE VIENE PORTATO AUTOMATICAMENTE IN BATTUTA CONTRO IL CORPO DELL'INTERMEDIARIO.
 TUBI DI COLLEGAMENTO AD INNESTO RAPIDO COMMERCIALI.

ADJUSTABLE PNEUMATIC ADAPTER.
 PNEUMATIC CLAMPING/MECHANICAL UNCLAMPING.
 FRONT INSTALLATION/DISINSTALLATION OF TOOLS.
 THE TOOLS ARE AUTOMATICALLY POSITIONED AND CENTERED.
 FAST COUPLING CONNECTIONS AND ITS JOINING PIPES AVAILABLE ON THE MARKET.

**APERTO
OPEN**

CORSA = 1mm
STROKE = 1mm

Scanalatura di sicurezza standard 8.4x3 (AMADA)
Standard safety groove 8.4x3 (AMADA)

Scanalatura supplementare cod. 70.1050 per montare il punzone frontalmente
Additional groove cod. 70.1050

Dentello anticaduta di sicurezza
Safety tooth

**CHIUSO
CLOSED**

FORZA
DI BLOCCAGGIO A 10 BAR=700 kg
CLAMPING POWER AT 10 BARS = 700 Kg

Punzone automaticamente posizionato e centrato.
Tool automatically positioned and centered.

CENTRALINA PNEUMATICA
PNEUMATIC EQUIPMENT

50.650
A 1 COMANDO
ONE CONTROL

50.651
A 2 COMANDI
TWO CONTROLS

CODE	A	H	T/Mt	Mt
50.600	7	100.00	100	■
50.610	7	120.00	100	■
50.615	7	150.00	100	■
50.640	20	120.00	100	■
50.646	20	150.00	100	■

CLARK

CODE	A	H	T/Mt	Mt
50.730	7	100.00	100	■
50.725	7	150.00	100	■
50.731	20	120.00	100	■

CLARK REVERSIBLE

CODE	A	H	T/Mt	Mt
50.635	7	100.00	100	■
50.685	7	150.00	100	■
50.645	20	120.00	100	■
50.657	20	150.00	100	■

CLARK "FP"

ADATTATORI PNEUMATICI / PNEUMATIC ADAPTERS

CODE	S	A	CODE	CODE
63.121	15x15	90	60.685	63.000
63.122	30x15	120	Z	K
63.123	45x15	150		
63.124	60x15	180		

STAFFA PNEUMATICA INDIPENDENTE PER TAVOLE CON FORATURA AMADA
PNEUMATIC FREE STANDING CLAMP FOR AMADA PRESS-BRAKES LOWER TABLES

CODE	S	A	CODE	CODE
63.126	13x15	90	63.012	63.001
63.127	27x15	120	Z	K
63.128	42x15	150		
63.129	57x15	180		

STAFFA PNEUMATICA INDIPENDENTE PER TAVOLE SCANALATE
PNEUMATIC FREE STANDING CLAMP FOR GROOVED LOWER TABLES

CODE
60.691

SCHEMA DI MONTAGGIO - ASSEMBLY SCHEME

415 mm

835 mm

RIALZO PORTAMATRICE MODULARE A BLOCCAGGIO PNEUMATICO E SBLOCCAGGIO A MOLLA.
MODULAR HOLDER, PNEUMATIC CLAMPING SPRING UNCLAMPING.

CODE
50.650

CENTRALINA PNEUMATICA AD 1 COMANDO
PNEUMATIC EQUIPMENT WITH 1 CONTROL

CODE
50.651

CENTRALINA PNEUMATICA A 2 COMANDI
PNEUMATIC EQUIPMENT WITH 2 CONTROLS

YELLOW LINE

LAME RETTILINEE PER CESOIA
RECTILINEAR SHEAR BLADES

1 / 2 / 4 TAGLIENTI
1 / 2 / 4 CUTTING EDGES



YELLOW LINE

LAME PER CESOIA
SHEAR BLADES



LAME PER CESOIA / SHEAR BLADES

LE LAME SONO ADATTE AL TAGLIO DI LAMIERA CON RESISTENZA FINO A 750 kN/mm²
 THE BLADES ARE SUITABLE FOR CUTTING SHEETS METAL WITH RESISTANCE UP TO 750 kN/mm²

1 SHARP

SPECIFICARE DIMENSIONI
 SPECIFY DIMENSIONS

A =
 B =
 C =
 D =
 E =

LEGENDA	A = LUNGHEZZA	B = ALTEZZA	C = DISTANZA TRA I FORI	D = DIAMETRO FORI
LEGEND	A = LENGHT	B = HEIGHT	C = DISTANCE BETWEEN HOLES	D = DIAMETER HOLES

LAMA SUPERIORE / INFERIORE A 1 TAGLIENTE
 BLADE UPPER / LOWER - 1 CUTTING EDGE WITH THREADED HOLE

2 SHARP

SPECIFICARE DIMENSIONI
 SPECIFY DIMENSIONS

A =
 B =
 C =
 D =
 E =

LEGENDA	A = LUNGHEZZA	B = ALTEZZA	C = DISTANZA TRA I FORI	D = DIAMETRO FORI
LEGEND	A = LENGHT	B = HEIGHT	C = DISTANCE BETWEEN HOLES	D = DIAMETER HOLES

LAMA SUPERIORE / INFERIORE A 2 TAGLIENTI
 BLADE UPPER / LOWER - 2 CUTTING EDGES WITH THREADED HOLE

4 SHARP

SPECIFICARE DIMENSIONI
 SPECIFY DIMENSIONS

A =
 B =
 C =
 D =
 E =

LEGENDA	A = LUNGHEZZA	B = ALTEZZA	C = DISTANZA TRA I FORI	D = DIAMETRO FORI
LEGEND	A = LENGHT	B = HEIGHT	C = DISTANCE BETWEEN HOLES	D = DIAMETER HOLES

LAMA SUPERIORE / INFERIORE A 4 TAGLIENTI
 BLADE UPPER / LOWER - 4 CUTTING EDGES WITH THREADED HOLE

GREEN LINE

SQUADRE DI RIFERIMENTO STANDARD E MAGNETICHE
STANDARD AND MAGNETICS SQUARING ARMS

RIFERIMENTI E ARRESTI MICROMETRICI

FRONT REFERENCE AND TRIP STOP WITH MICROMETER ADJUSTMENT

GONIOMETRO DIGITALE E KIT PROTEZIONE E PULIZIA

DIGITAL ANGLE GAUGES AND CLEANING KIT

ARMADIO PORTAUTENSILI AMADA / WILA / TRUMPF / BYSTRONIC / LVD

TOOLING CABINET AMADA / WILA / TRUMPF / BYSTRONIC / LVD



GREEN LINE

ACCESSORI PER TUTTE LE PRESSE
ACCESSORIES FOR ALL PRESS BRAKES



ACCESSORI PER TUTTE LE PRESSE / ACCESSORIES FOR ALL PRESS BRAKES

CODE

40.740



SQUADRA DI RIFERIMENTO MAGNETICA 0° - 90°
MAGNETIC SQUARING ARM 0° - 90°

SINISTRA
LEFT

CODE

40.745



SQUADRA DI RIFERIMENTO MAGNETICA 0° - 90°
MAGNETIC SQUARING ARM 0° - 90°

DESTRA
RIGHT

CODE

40.660



SQUADRA DI RIFERIMENTO STANDARD FISSA 90°
NOT ADJUSTABLE SQUARING ARM 90°

CODE

40.700



SQUADRA DI RIFERIMENTO STANDARD ORIENTABILE 60° - 120°
ADJUSTABLE SQUARING ARM 60° - 120°

CODE

40.750



SQUADRA DI RIFERIMENTO MAGNETICA 30° - 90°
MAGNETIC, DOUBLE ADJUSTABLE SQUARING ARM 30° - 90°

CODE

40.010

KIT PROTEZIONE E PULIZIA
PROTECTION & CLEANING KIT



1 BOMBOLETTA, 1 SPUGNA ABRASIVA E UN PAIO DI GUANTI
1 BOTTLE, 1 ABRASIVE SPONGE AND A PAIR OF GLOVES

ACCESSORI PER TUTTE LE PRESSE / ACCESSORIES FOR ALL PRESS BRAKES

CODE

40.015



GONIOMETRO DIGITALE CON RISOLUZIONE DI 0,1°
MISURAZIONE ANGOLI DA 0° A 360°
DIGITAL ANGLE GAUGE WITH RESOLUTION OF 0,1°
MEASURING ANGLES FROM 0° TO 360°

CODE

40.016



GONIOMETRO DIGITALE CON RISOLUZIONE DI 0,1°
MISURAZIONE ANGOLI DA 0° A 360°
DIGITAL ANGLE GAUGE WITH RESOLUTION OF 0,1°
MEASURING ANGLES FROM 0° TO 360°

CODE

40.146



ARRESTO A REGOLAZIONE MICROMETRICA
TRIP STOP WITH MICROMETER ADJUSTMENT

CODE

40.157



ARRESTO SENZA REGOLAZIONE MICROMETRICA
TRIP STOP WITHOUT MICROMETER ADJUSTMENT

CODE

60.617



STAFFA RR
ARM CLAMP

CODE

60.618



STAFFA
LOWER TOOL CLAMP

CODE

60.619



RONDELLA PER STAFFA
CLAMP WASHER

CODE

40.260



SUPPORTO TIPO RR
FRONT SUPPORT AND GAUGE ARMS

ARMADIO PORTAUTENSILI / TOOLING CABINET

ALTRI COLORI SU RICHIESTA
OTHER COLOUR ON REQUEST



LEGENDA	LUNGHEZZA MAX. STAMPI	Q = N° MAX. STAMPI	C = COLORE	P = PESO
LEGEND	L = MAX LENGHT TOOLS	Q = MAX TOOLS N°	C = COLOUR	P = WEIGHT

CODE	L	Q	P	C
40.645	835 mm	30	200 Kg	■



AMADA - PROMECAM

CODE	L	Q	P	C
40.650	835 mm	55	260 Kg	■

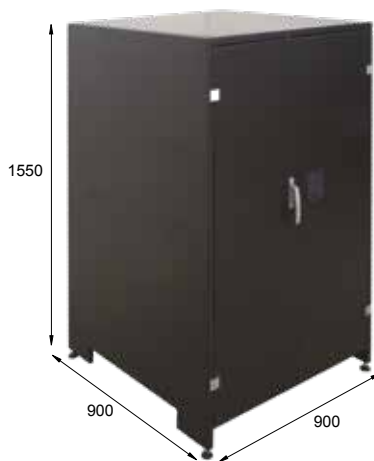

AMADA - PROMECAM

CODE	L	Q	P	C
40.651	835 mm	55	330 Kg	■



AMADA - PROMECAM

CODE	L	Q	P	C
40.652	1100 mm	55	450 Kg	■



WILA - TRUMPF - BYSTRONIC - LVD

CODE	L	Q	P	C
40.653	1100 mm	30	300 Kg	■



WILA - TRUMPF - BYSTRONIC - LVD

SILVER LINE

PUNZONI

PUNCHES



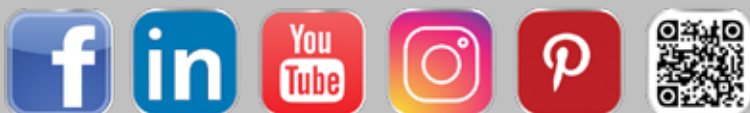

SILVER LINE

LAVORAZIONI - MODIFICHE - RICONDIZIONAMENTO UTENSILI
WORKING - MODIFICATION - REFURBISHED TOOLING

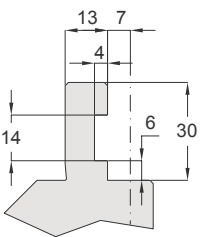
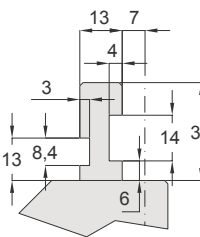
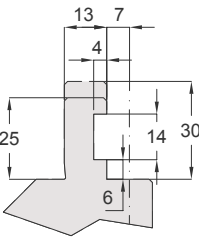
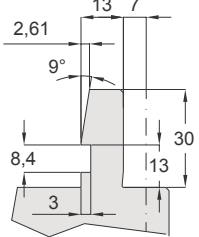
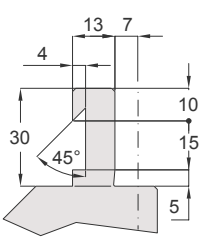
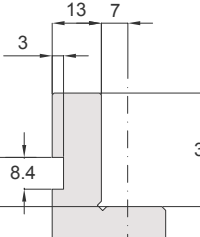
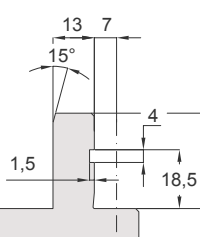
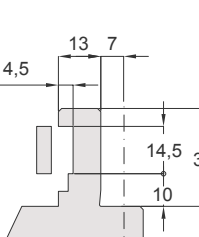
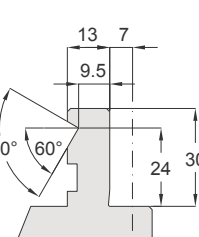
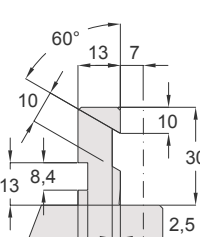
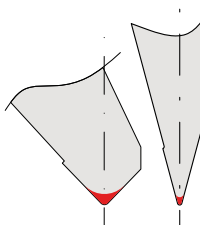

LAVORAZIONE E MODIFICA PUNZONI / PUNCHES WORKING AND MODIFICATION

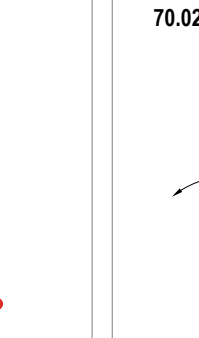
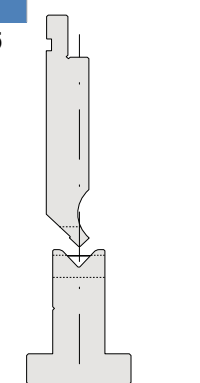
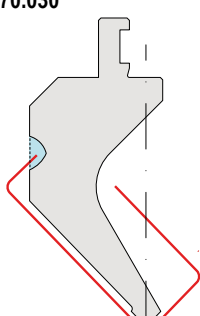
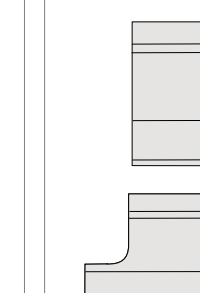
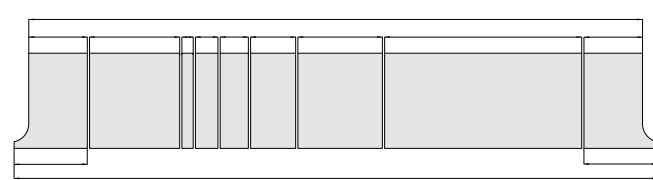
<p>CODE 70.500</p>  <p>EURO - BEYELER</p>	<p>CODE 70.501</p>  <p>EUROBEYELER - EURO WILA</p>	<p>CODE 70.502</p>  <p>DONEWELL - SAFAN - EUROBEYELER</p>	<p>CODE 70.504</p>  <p>AMADA ONE TOUCH</p>	<p>CODE 70.600</p>  <p>GASPARINI</p>
<p>CODE 70.946</p>  <p>AMADA / PROMECAM</p>	<p>CODE 70.947</p>  <p>COLGAR OLD STYLE</p>	<p>CODE 70.948</p>  <p>AMADA OLD STYLE</p>	<p>CODE 70.949</p>  <p>AMADA - BMB IDRAULIC</p>	<p>CODE 70.1050</p>  <p>AMADA - PROMECAM (CLARK)</p>
<p>CODE 70.010</p>  <p>MODIFICA PUNZONI DI RETTIFICA GRINDING MODIFY OF PUNCHES</p>	<p>CODE 70.015</p>  <p>MODIFICHE FINESTRE PUNZONI WINDOWS FOR SHORT U PROFILES</p>	<p>CODE 70.020</p>  <p>MODIFICHE FINESTRE PUNZONI WINDOWS FOR SHORT U PROFILES</p>	<p>CODE 70.025</p>  <p>MODIFICHE NERVATURE PUNZONI BEADING IN THE BENDING</p>	
<p>CODE 70.030</p>  <p>MODIFICA FRESATURA PUNZONI MILLING MODIFY OF PUNCHES</p>	<p>CODE 70.035</p>  <p>SCARPETTA SINGOLA PUNZONI SPECIAL SINGLE HORN PUNCHES</p>	<p>CODE FRAZIONATURA PUNZONI SU RICHIESTA 70.040 PUNCH SECTIONED ON REQUEST</p>  <p>FRAZIONATURA SPECIALE PUNZONI SPECIAL SECTIONING PUNCHES</p> <p>SPECIFICARE LUNGHEZZE SPECIFY LENGTHS</p>		

SILVER LINE

MATRICI

DIES

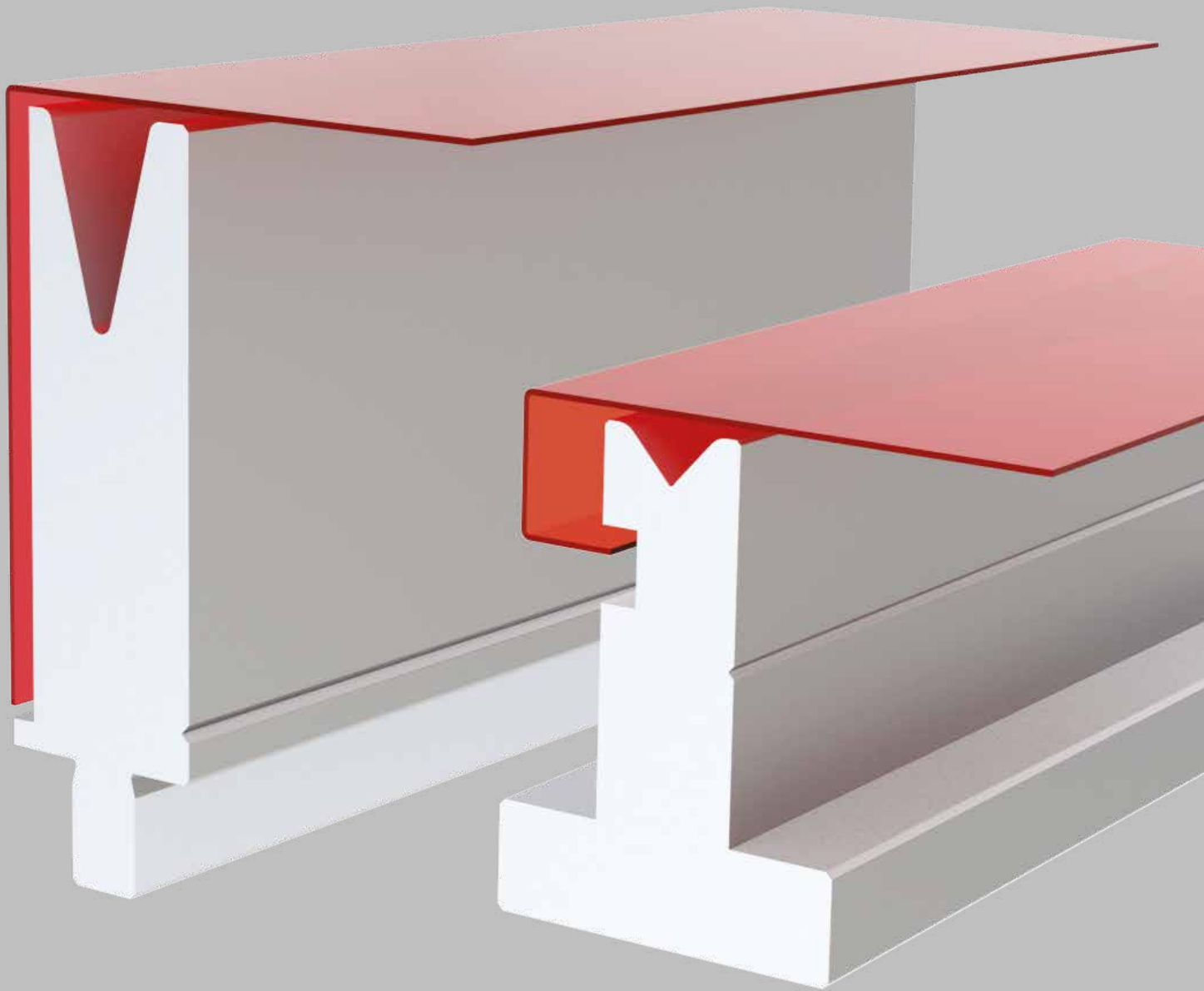

SILVER LINE

LAVORAZIONI - MODIFICHE - RICONDIZIONAMENTO UTENSILI
WORKING - MODIFICATION - REFURBISHED TOOLING



LAVORAZIONE E MODIFICA MATRICI / DIES WORKING AND MODIFICATION

CODE
70.050

MODIFICA MATRICI DI RETTIFICA
GRINDING MODIFY OF DIES

CODE
70.060

MODIFICA MATRICI DI FRESATURA
MILLING MODIFY OF DIES

CODE
70.900

SCANALATURA V-LOCK X MATRICI WILA
SAFETY GROOVE V-LOCK FOR WILA DIES

CODE 70.070 **FRAZIONATURA MATRICI SU RICHIESTA**
DIES SECTIONED ON REQUEST

FRAZIONATURA SPECIALE MATRICI
SPECIAL SECTIONING OF DIES

SPECIFICARE LUNGHEZZE
SPECIFY LENGTHS

CODE
60.100

INSERTO + MODIFICA
BAR + MODIFICATION

AMADA / WILA - BYSTRONIC

CODE
60.150

INSERTO + MODIFICA
BAR + MODIFICATION

AMADA / LVD

CODE
60.200

INSERTO + MODIFICA
BAR + MODIFICATION

AMADA / AMERICAN

GOLD LINE
UTENSILI SPECIALI
SPECIAL TOOLS



GOLD LINE

UTENSILI SPECIALI PER TUTTE LE PRESSE
SPECIAL TOOLING FOR ALL PRESS BRAKES

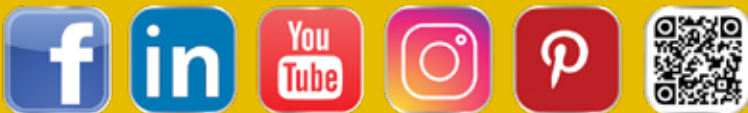

UTENSILI SPECIALI / SPECIAL TOOLING



GROUP - A / STAMPI SPECIALI MONOLITICI - DIMENSIONI MASSIME: PUNZONE 140mm x 60mm - MATRICE 120mm x 100mm
 MONOLITIC SPECIAL TOOLS - MAX. DIMENSIONS: PUNCH 140mm x 60mm / DIE 120mm x 100mm

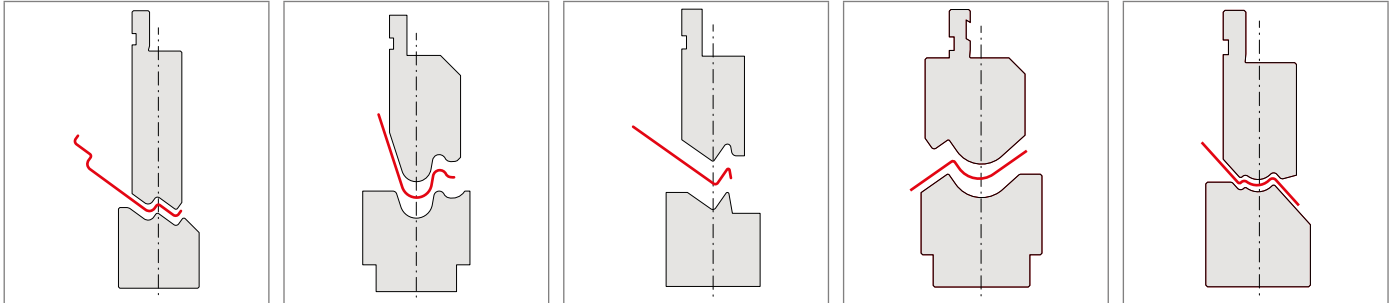

CONSEGNA: 7 SETTIMANE DA RICEVIMENTO ORDINE / DELIVERY TIME: 7 WORKING WEEKS FROM DATA ORDER

GROUP - B / STAMPI SPECIALI CON INSERTI REGISTRABILI - DIMENSIONI MASSIME: PUNZONE 140mm x 60mm - MATRICE 120mm x 100mm
 SPECIAL TOOLING WITH ADJUSTABLE INSERTS - MAX. DIMENSIONS: PUNCH 140mm x 60mm / DIE 120mm x 100mm

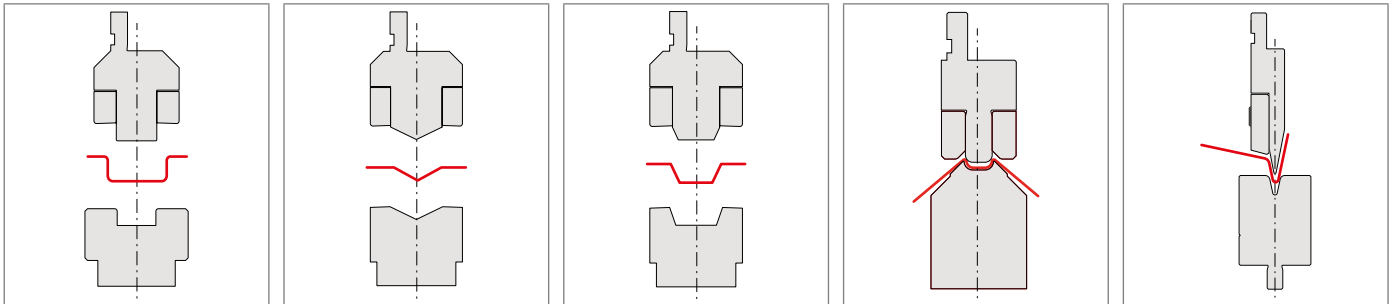

CONSEGNA: 7 SETTIMANE DA RICEVIMENTO ORDINE / DELIVERY TIME: 7 WORKING WEEKS FROM DATA ORDER

GROUP - C / STAMPI SPECIALI CON PREMILAMIERA - DIMENSIONI MASSIME: PUNZONE 140mm x 60mm - MATRICE 120mm x 100mm
 SPECIAL TOOLING WITH COUNTERHOLDER - MAX. DIMENSIONS: PUNCH 140mm x 60mm / DIE 120mm x 100mm

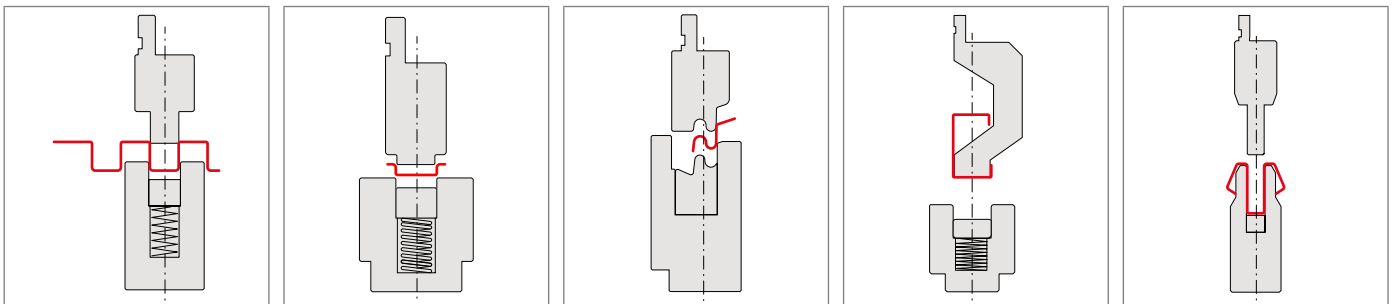

CONSEGNA: 8 SETTIMANE DA RICEVIMENTO ORDINE / DELIVERY TIME: 8 WORKING WEEKS FROM DATA ORDER

GROUP - D / STAMPI SPECIALI CON INSERTI E PREMILAMIERA - DIMENSIONI MASSIME: PUNZONE 140mm x 60mm - MATRICE 120mm x 100mm
 SPECIAL TOOLING WITH INSERT AND COUNTERHOLDER - MAX. DIMENSIONS: PUNCH 140mm x 60mm / DIE 120mm x 100mm

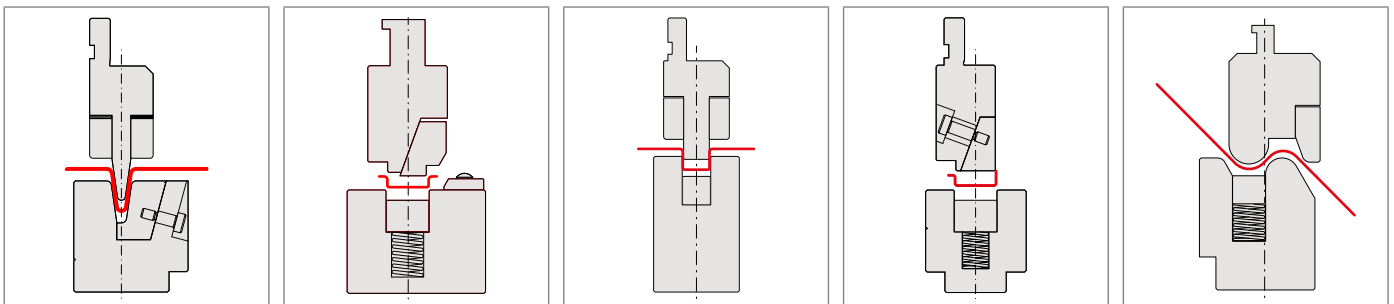

CONSEGNA: 8 SETTIMANE DA RICEVIMENTO ORDINE / DELIVERY TIME: 8 WORKING WEEKS FROM DATA ORDER

UTENSILI SPECIALI / SPECIAL TOOLING

GROUP - E / PIEGASCHIACCIA SPECIALI - DIMENSIONI MASSIME: PUNZONE 140mm x 60mm - MATRICE 120mm x 100mm SPECIAL HEMMING TOOLS - MAX. DIMENSIONS: PUNCH 140mm x 60mm / DIE 120mm x 100mm

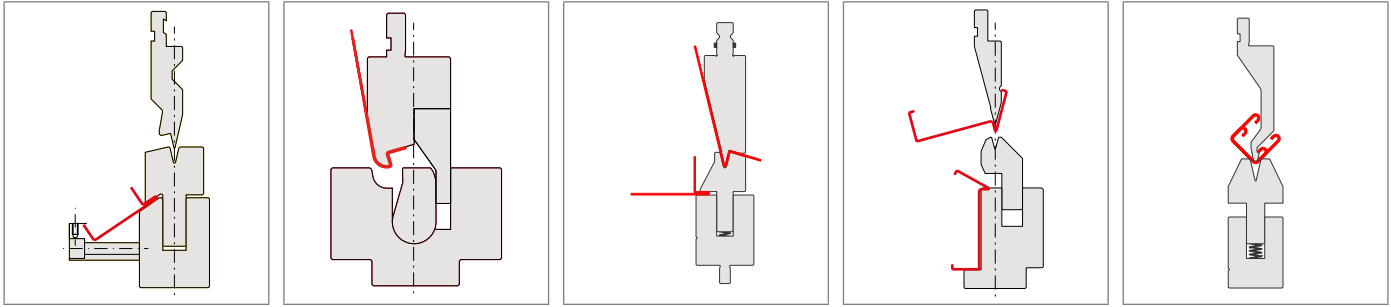

CONSEGNA: 8 SETTIMANE DA RICEVIMENTO ORDINE / DELIVERY TIME: 8 WORKING WEEKS FROM DATA ORDER

GROUP - F / STAMPI SPECIALI CON CINEMATISMO ED INSERTI BASCULANTI - DIMENSIONI MASSIME: PUNZONE 140mm x 60mm - MATRICE 120mm x 100mm SPECIAL TOOLING WITH CAM MECHANISM - MAX. DIMENSIONS: PUNCH 140MM X 60MM / DIE 120MM X 100MM

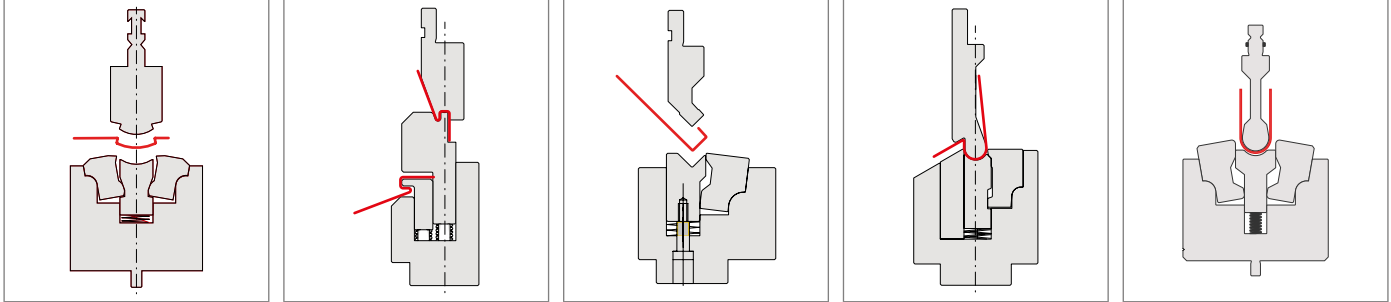

CONSEGNA: 10 SETTIMANE DA RICEVIMENTO ORDINE / DELIVERY TIME: 10 WORKING WEEKS FROM DATA ORDER

GROUP - G1 / STAMPI SPECIALI PER CERNIERE DI PICCOLE DIMENSIONI (Ø5 - Ø8) SPECIAL HINGE TOOLS OF SMALL SIZE (Ø5 - Ø8)

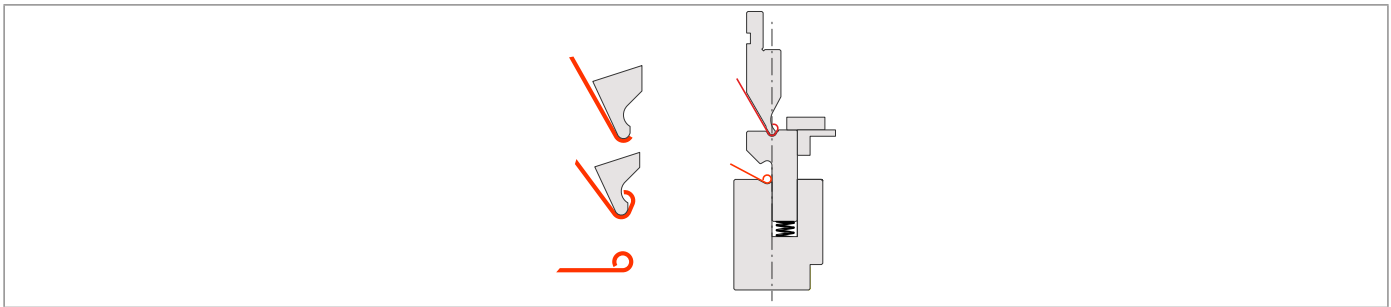

CONSEGNA: 8 SETTIMANE DA RICEVIMENTO ORDINE / DELIVERY TIME: 8 WORKING WEEKS FROM DATA ORDER

GROUP - G2 / STAMPI SPECIALI PER CERNIERE DI MEDIE DIMENSIONI (Ø9 - Ø12) SPECIAL HINGE TOOLS OF MID SIZE (Ø9 - Ø12)

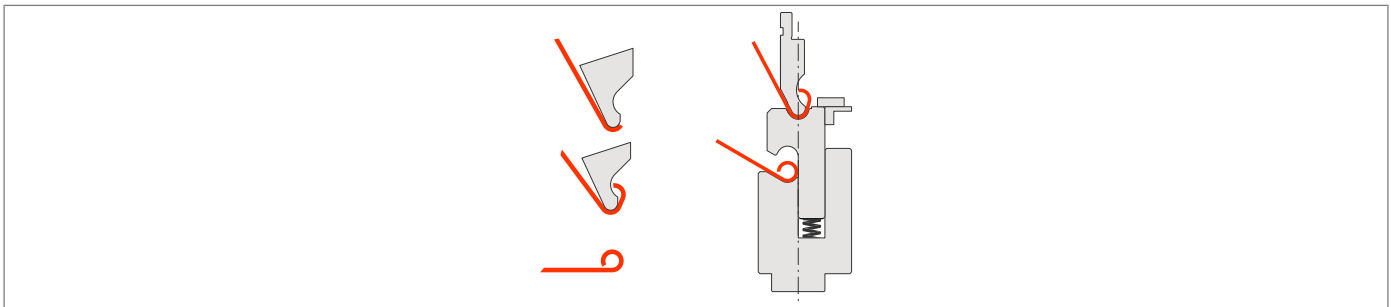

CONSEGNA: 8 SETTIMANE DA RICEVIMENTO ORDINE / DELIVERY TIME: 8 WORKING WEEKS FROM DATA ORDER

GROUP - G3 / STAMPI SPECIALI PER CERNIERE DI GRANDI DIMENSIONI (Ø13 - Ø16) SPECIAL HINGE TOOLS OF BIG SIZE (Ø13 - Ø16)

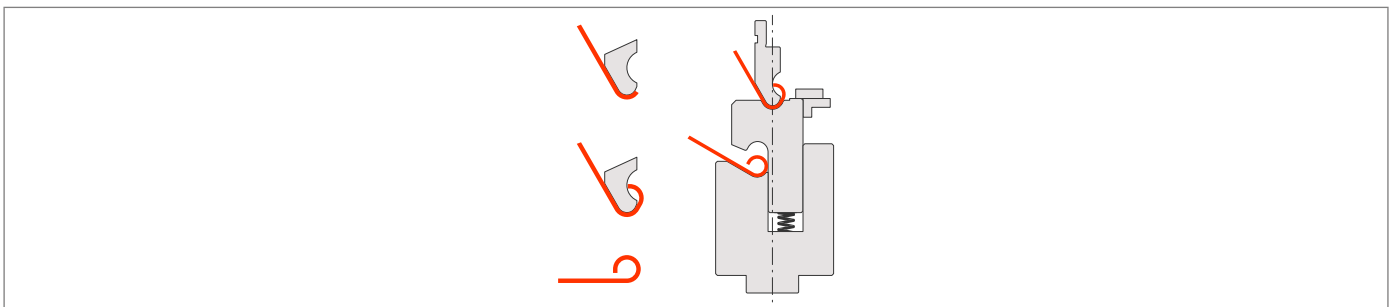

CONSEGNA: 8 SETTIMANE DA RICEVIMENTO ORDINE / DELIVERY TIME: 8 WORKING WEEKS FROM DATA ORDER



 Tecnostamp s.r.l.

 Via Vittime della Pertite, 71 - Piacenza - 29121 - Italia

 +39 0523 499712 - Fax +39 0523 497020

 tecnostamp@tecnostamp.it

 PIVA 12988040155 - C.F. 00326630332

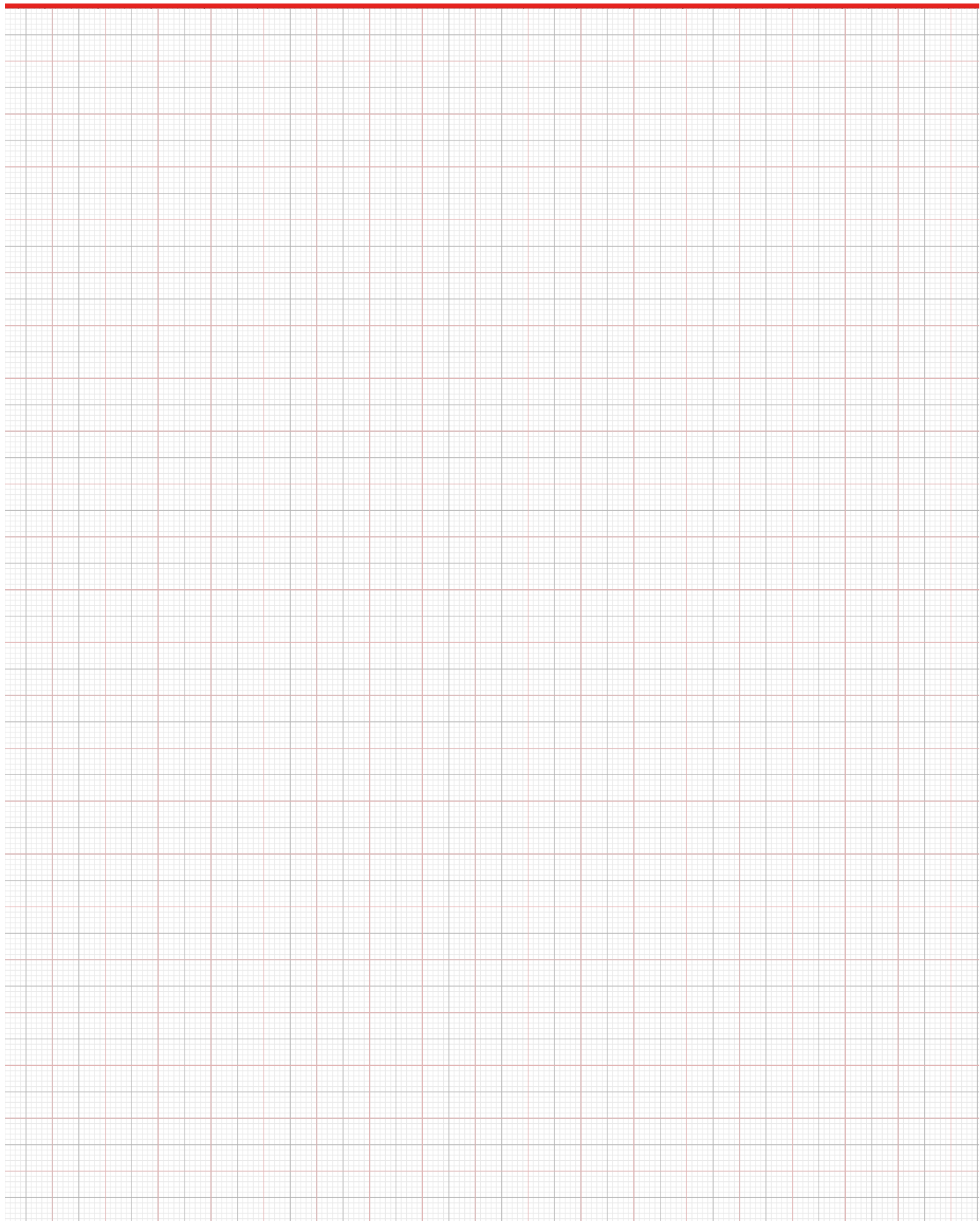

I NOSTRI CATALOGHI - OUR CATALOGS

AMADA
PROMECAM



RED LINE

TRUMPF



BLUE LINE

WILA



PLATINUM LINE

BYSTRONIC
BEYELER



ORANGE LINE

LVD



BLACK LINE

AJIAL
AMERICAN
COLGAR
COLLY
HÄMMERLE
EHT
NEWTON
WEINBRENNER



RAINBOW LINE

BLADES
HOLDERS
RADIUS



SKY LINE

NO
MARKING
TOOLS



CORAL LINE

ADAPTERS
FOR ALL
PRESS
BRAKES



MAGENTA LINE

SHEAR
BLADES



YELLOW LINE

ACCESSORIES
FOR ALL
PRESS
BRAKES



GREEN LINE

WORKING
MODIFICATION
REFURBISHED
TOOLING



SILVER LINE

SPECIAL
TOOLING
FOR ALL PRESS
BRAKES



GOLD LINE

I CATALOGHI SONO DISPONIBILI SUL SITO WEB
THE CATALOGS ARE AVAILABLE ON THE WEBSITE
WWW.TECNOSTAMP.EU



SCARICA LA NOSTRA APP PER IOS O ANDROID
DOWNLOAD OUR APP FOR IOS OR ANDROID



TecnosTamp



Via Vittime della Pertite,71
29121 Piacenza ITALIA
Tel +39 0523 499712 - Fax +39 0523 497020
www.tecnostamp.eu - tecnostamp@tecnostamp.it